

SARAY[®] | Alüminyum

Mükemmel yapılar için...

EW55
TEST RAPORLARI

Nachweis

Widerstandsfähigkeit bei Windlast
Luftdurchlässigkeit
Bedienkräfte

Prüfbericht 102 39008/3



Auftraggeber **SARAY Aluminium**
Baglar Mahallesi Osmanpasa Cad. No.:89

Günesli / Istanbul, 34540
Türkei

Grundlagen

EN 14351-1 : 2006-03

Prüfnormen:

EN 1026 : 2000-06

EN 12211 : 2000-06

EN 12046-1 : 2003-11

EN 14609 : 2004-03

Entsprechende nationale
 Fassungen (DIN EN)

Produkt **Einfügeliges Drehkipfenster**

System **EW 55**

Darstellung

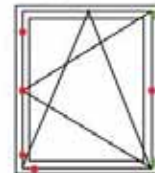

Außenmaß (B x H) **1200 mm x 1500 mm**

Rahmenmaterial **Aluminium-Kunststoff-Verbundprofil**

Besonderheiten **-/-**

Verwendungshinweise

Dieser Prüfbericht dient zum Nachweis der aufgeführten Eigenschaften für Fenster nach EN 14351-1 : 2006-03. Die ermittelten Ergebnisse können vom Hersteller als Grundlage für den herstellereigenen zusammenfassenden ITT-Bericht verwendet werden. Die Festlegungen aus EN 14351-1 : 2006-03 sind zu beachten.

Gültigkeit

Die genannten Daten und Ergebnisse beziehen sich ausschließlich auf den geprüften und beschriebenen Probekörper.

Die Prüfergebnisse können nach EN 14351-1, unter Beachtung von Anlage E.1, in Eigenverantwortung des Herstellers übertragen werden.

Diese Prüfung ermöglicht keine Aussage über weitere Leistungs- und qualitätsbestimmenden Eigenschaften der vorliegenden Konstruktion; insbesondere Witterungs- und Alterungserscheinungen wurden nicht berücksichtigt.

Veröffentlichungshinweise

Es gilt ift-Merkblatt „Bedingungen und Hinweise zur Benutzung von ift-Prüfdokumentationen“.

Das Deckblatt kann als Kurzfassung verwendet werden.

Inhalt

Der Nachweis umfasst insgesamt 8 Seiten

Widerstandsfähigkeit bei Windlast – EN 12210



Klasse C2 / B2

Luftdurchlässigkeit – EN 12207



Klasse 3

Bedienkräfte – EN 13115



Klasse 1

ift Rosenheim
3. März 2010

Jochen Peicht, Dipl.-Ing. (FH)
Prüfstellenleiter
ift Zentrum Fenster & Fassaden

Robert Kolecny, Dipl.-Ing. (FH)
Prüfingenieur
ift Zentrum Fenster & Fassaden



ift Rosenheim GmbH
Geschäftsführer:
Dipl.-Ing. (FH) Ulrich Sieberath
Dr. Jochen Peicht

Theodor-Giell-Str. 7 - 9
D-83026 Rosenheim
Tel.: +49 (0)8031/261-0
Fax: +49 (0)8031/261-290
www.ift-rosenheim.de

Sitz: 83026 Rosenheim
AG Traunstein, HRB 14763
Sparkasse Rosenheim
Kto. 3822
BLZ 711 500 00

Notified Body Nr.: 0757
Anerkannte PUZ-Stelle: BAY 18

DAFR
DIPLOM-GENÜSSIG
DAFR-26-2204-09
DAFR-26-16-09-09
DAFR-26-16-09-09

Nachweis Wärmedurchgangskoeffizient

Prüfbericht 423 39008/2



Auftraggeber **SARAY Aluminium**
Baglar Mahallesi Osmanpasa Cad. No:89

34540 Günesli / Istanbul
Türkei

Grundlagen

EN ISO 10077-1 : 2006-09
Wärmetechnisches Verhalten
von Fenstern, Türen und Ab-
schlüssen - Berechnung des
Wärmedurchgangskoeffizienten
- Teil 1: Vereinfachtes Verfah-
ren

Produkt	Einfachfenster, einflügelig
Bezeichnung	EW 55
Außenmaß (B x H in mm)	1200 x 1500
(Rahmen) Material	Thermisch getrennte Metallprofile
Öffnungsart	Drehkipp Mehrscheiben-Isolierglas mit $U_g = 2,8 \text{ W}/(\text{m}^2 \cdot \text{K})$ nach EN 673, Aufbau: 6 12 6 mm, Gasfüllung: Luft, 100 %
Füllung	Abstandhalter: Aluminium
Besonderheiten	-/-

Darstellung



Verwendungshinweise

Dieser Prüfbericht dient zum
Nachweis des Wärmedurch-
gangskoeffizienten U_{w} .

Gültigkeit

Die genannten Daten und Er-
gebnisse beziehen sich aus-
schließlich auf den geprüften
und beschriebenen Gegen-
stand.

Die Prüfung des Wärmedurch-
gangskoeffizienten ermöglicht
keine Aussage über weitere
leistungs- und qualitätsbestim-
mende Eigenschaften der vor-
liegenden Konstruktion.

Veröffentlichungshinweise

Es gilt das ift-Merkblatt „Bedin-
gungen und Hinweise zur Be-
nutzung von ift-
Prüfdokumentationen“.

Das Deckblatt kann als Kurz-
fassung verwendet werden.

Inhalt

Der Nachweis umfasst insge-
samt 5 Seiten

- 1 Gegenstand
- 2 Durchführung
- 3 Einzelergebnisse

Wärmedurchgangskoeffizient



$$U_w = 3,1 \text{ W}/(\text{m}^2 \cdot \text{K})$$



ift Rosenheim
18. Februar 2010

Klaus Specht

Klaus Specht, Dipl.-Ing. (FH)
Stv. Prüfstellenleiter
ift Zentrum Glas Baustoffe Bauphysik

Manuel Demel

Manuel Demel, Dipl.-Ing. (FH)
Prüfingenieur
ift Zentrum Glas, Baustoffe & Bauphysik

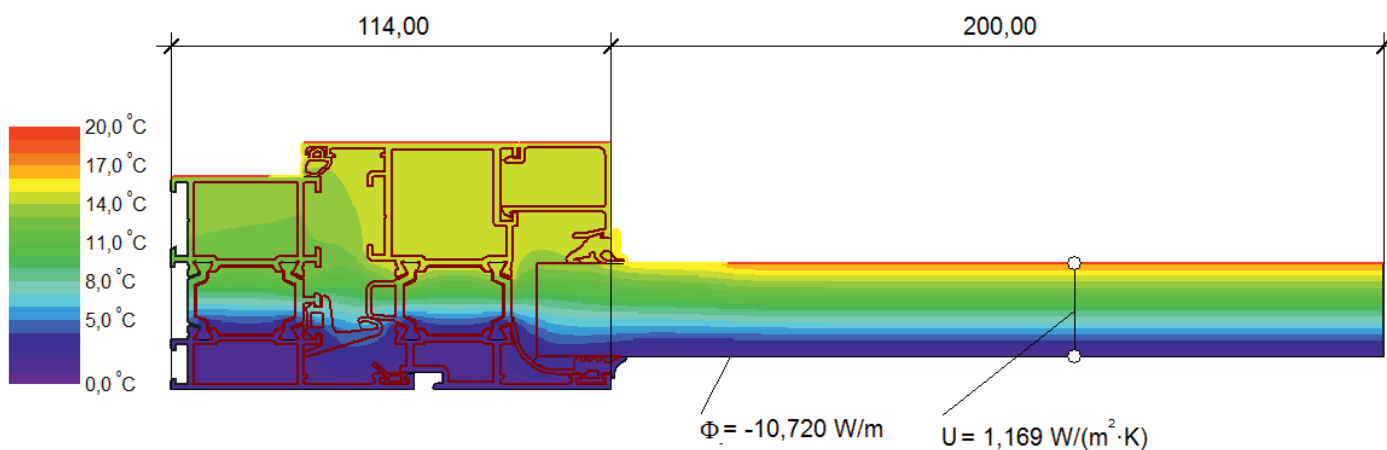
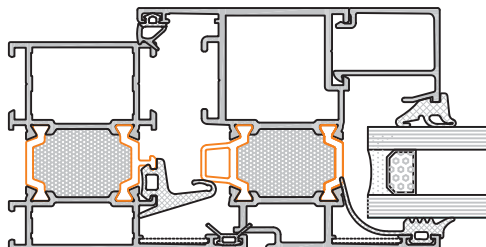
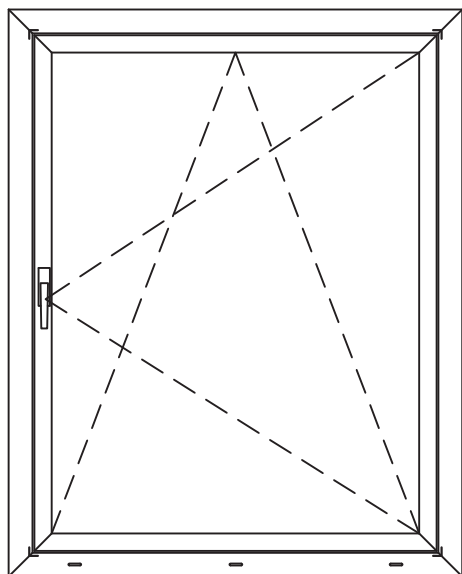



$$U_f = \frac{\frac{\Phi}{\Delta T} - U_p \cdot b_p}{b_f} = \frac{\frac{10,720}{20,000} - 1,169 \cdot 0,200}{0,114} = 2,65 \text{ W/(m}^2 \cdot \text{K)}$$

Material	λ [W/(m·K)]	ϵ	Boundary Condition	q [W/m ²]	θ [°C]	R [(m ² ·K)/W]	ϵ
Aluminium (Si Alloys)	160,000	0,900	Epsilon 0.9				0,900
EPDM (ethylene propylene diene monomer)	0,250	0,900	Exterior, frame	0,000		0,040	
Foam	0,038	0,900	Interior, frame, normal	20,000		0,130	
Panel	0,035	0,900	Interior, frame, reduced	20,000		0,200	
Polyamid 6.6 with 25% glass fibre	0,300	0,900	Symmetry/Model section	0,000			
Unventilated air cavity	anisotropic						

**EW55
WINDOWS and DOORS
SYSTEM
ALUMINIUM PROFILES**

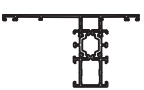
**EW55 KAPI ve PENCERE
SİSTEMİ
ALUMİNYUM PROFİLLER**

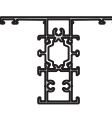





ALUMINIUM PROFILES Aluminyum Profiller				
PROFİL RESMİ DRAWING	PROFİL NO PROFILE NO	AĞIRLIK WEIGHT (kg/m)	DESCRIPTION PROFİL TANIMLAMASI	STATIC VALUE Jx (cm4) / Jy (cm4)
	55-9001/9002	1,265	26 mm MULLION PROFILE 26 mm Ortakayıt Profili	11,56 / 8,55
	**55-9001/9002-P	1,275	26 mm Polyurethane Filled Mullion Profile 26mm Poliüretan Dolgulu Ortakayıt Profili	
	55-9001/9015	1,140	26 mm FRAME PROFILE 26 mm Kasa Profili	10,04 / 4,86
	**55-9001/9015-P	1,150	26 mm Polyurethane Filled Frame Profile 26 mm Poliüretan Dolgulu Kasa Profili	
	55-9001/9028	1,420	26mm OVAL FRAME PROFILE 26mm Oval Kasa Profili	18,06 / 8,07
	**55-9001/9028-P	1,430	26 mm Polyurethane Filled Oval Frame Profile 26 mm Poliüretan Dolgulu Oval Kasa Profili	
	55-9001/9034	1,540	MULLION PROFILE for HIDDEN SASH Gizli kanat Ortakayıt Profili	13,95 / 38,85
	**55-9001/9034-P	1,550	Polyurethane Filled Mullion Profile for Hidden Sash Poliüretan Dolgulu Gizli kanat Ortakayıt Profili	
	55-9001/9035	1,270	FRAME PROFILE for HIDDEN SASH Gizli kanat Kasa Profili	11,67 / 16,80
	**55-9001/9035-P	1,280	Polyurethane Filled Frame Profile for Hidden Sash Poliüretan Dolgulu Gizli Kanat Kasa Profili	
	55-9001/9059	1,390	ASYMMETRIC FRAME PROFILE for HIDDEN SASH Asimetrik gizli kanat Kasa Profil	12,86 / 22,10
	**55-9001/9059-P	1,400	Polyurethane Filled Asymmetric Frame Profile for Hidden Sash Poliüretan Dolgulu Asimetrik gizli kanat Kasa Pr.	
	55-9003/9004	1,465	39mm MULLION PROFILE 39mm Ortakayıt Profili	13,89 / 16,27
	**55-9003/9004-P	1,490	39 mm Polyurethane Filled Mullion Profile 39 mm Poliüretan Dolgulu Ortakayıt Profili	
	55-9003/9016	1,335	39 mm FRAME PROFILE 39 mm Kasa Profili	12,30 / 10,75
	**55-9003/9016-P	1,360	39 mm Polyurethane Filled Frame Profile 39 mm Poliüretan Dolgulu Kasa Profili	
	55-9003/9026	2,325	39mm MULLION PROFILE (REINFORCEMENT) 39mm Ortakayıt Profili (takviyeli)	96,57 / 24,82
	**55-9003/9026-P	2,350	39 mm Polyurethane Filled Frame Profile (REINFORCEMENT) 39 mm Poliüretan Dolgulu Kasa Pr.(takviyeli)	
	55-9003/9029	1,615	39 mm OVAL FRAME PROFILE 39 mm Oval Kasa Profili	21,70 / 16,38
	**55-9003/9029-P	1,640	39 mm Polyurethane Filled Oval Frame Profile 39 mm Poliüretan Dolgulu Oval Kasa Profili	
	55-9005/9006	1,375	26 mm MULLION PROFILE (with screw channel) 26mm Ortakayıt Profili vida kanallı	12,66 / 8,60
	**55-9005/9006-P	1,385	26 mm Polyurethane Filled MULLION PROFILE (with screw channel) 26 mm Poliüretan Dolgulu Ortakayıt Pr. (vida kanallı)	

** Sipariş miktarı minimum 100 boydur. / Minimum order quantity: 100 bar

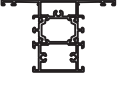
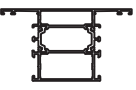
* Sipariş miktarı minimum 600 kg dır. / Minimum order quantity: 600 kg

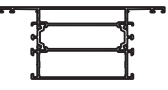
Uyarı: Profil ağırlıklarımız teorik olup; teslim anındaki tartımız geçerlidir.

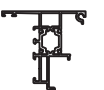
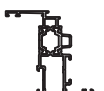
Warning: the weights of profile is theoretical, weighting at the time of delivery are valid.

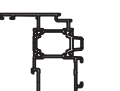
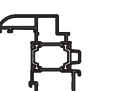





ALUMINIUM PROFILES Alüminyum Profiller				
PROFİL RESMİ DRAWING	PROFİL NO PROFILE NO	AĞIRLIK WEIGHT (kg/m)	DESCRIPTION PROFİL TANIMLAMASI	STATIC VALUE Jx (cm ⁴) / Jy (cm ⁴)
	55-9007/9008	1,565	39 mm MULLION PROFILE 39 mm Ortakayıt Profili	14,90 / 16,53
	**55-9007/9008-P	1,590	39 mm Polyurethane Filled Mullion Profile 39 mm Poliüretan Dolgulu Ortakayıt Profili	
	55-9009/9010	1,650	52 mm MULLION PROFILE 52 mm Ortakayıt Profili	16,19 / 27,96
	**55-9009/9010-P	1,690	52 mm Polyurethane Filled Mullion Profile 52 mm Poliüretan Dolgulu Ortakayıt Profili	
	55-9009/9017	1,535	52 mm FRAME PROFILE 52 mm Oval Kasa Profili	14,56 / 20,26
	**55-9009/9017-P	1,575	52 mm Polyurethane Filled Frame Profile 52 mm Poliüretan Dolgulu Kasa Profil	
	55-9011/9012	2,060	78 mm MULLION PROFILE 78 mm Ortakayıt Profili	20,76 / 65,69
	**55-9011/9012-P	2,130	78 mm Polyurethane Filled Mullion Profile 78 mm Poliüretan Dolgulu Ortakayıt Profili	
	55-9013/9014	2,810	117 mm MULLION PROFILE 117 mm Ortakayıt Profili	28,91 / 172,89
	**55-9013/9014-P	2,925	117 mm Polyurethane Filled Mullion Profile 117 mm Poliüretan Dolgulu Ortakayıt Profili	
	55-9018/9019	1,215	DOUBLE CASEMENT ADAPTER PROFILE Çift Kanat Adaptör Profili	11,06 / 6,69
	**55-9018/9019-P	1,225	Polyurethane Filled Double Casement Adapter Pr. Poliüretan Dolgulu Çift Kanat Adaptör Profili	
	55-9020/9021	1,250	43 mm SASH PROFILE 43 mm Kanat Profili	15,69 / 6,69
	**55-9020/9021-P	1,260	43 mm Polyurethane Filled Sash Profile 43 mm Poliüretan Dolgulu Kanat Profili	
	*55-9020/9030	1,415	43 mm OVAL SASH PROFILE 43 mm Oval Kanat Profili	21,64 / 8,76
	**55-9020/9030-P	1,425	43 mm Polyurethane Oval Filled Sash Pr. 43 mm Poliüretan Dolgulu Oval Kanat Profili	
	55-9020/9036	1,280	43 mm OVAL SASH PROFILE 43 mm Oval Kanat Profili	15,12 / 8,13
	**55-9020/9036-P	1,290	43 mm Polyurethane Filled Oval Sash Pr. 43 mm Poliüretan Dolgulu Oval Kanat Profili	
	55-9022/9023	1,465	56 mm SASH PROFILE 56 mm Kanat Profili	19,02 / 13,57
	**55-9022/9023-P	1,490	56 mm Polyurethane Filled Sash Profile 56 mm Poliüretan Dolgulu Kanat Profili	
	*55-9022/9031	1,645	56 mm OVAL SASH PROFILE 56 mm Oval Kanat Profili	26,10 / 17,06
	**55-9022/9031-P	1,670	56 mm Polyurethane Oval Filled Sash Pr. 56 mm Poliüretan Dolgulu Oval Kanat Profili	

** Sipariş miktarı minimum 100 boydur. / Minimum order quantity: 100 bar

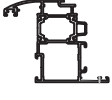
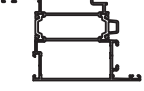
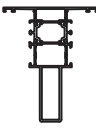
* Sipariş miktarı minimum 600 kg dır. / Minimum orde quantity: 600 kg

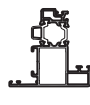
Uyarı: Profil ağırlıklarımız teorik olup; teslim anındaki tartımız geçerlidir.

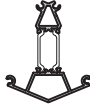
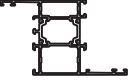
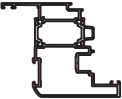
Warning: the weights of profile is theoretical, weighting at the time of delivery are valid.

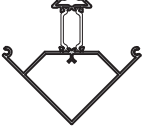



ALUMINIUM PROFILES Aluminyum Profiller				
PROFİL RESMİ DRAWING	PROFİL NO PROFILE NO	AĞIRLIK WEIGHT (kg/m)	DESCRIPTION PROFİL TANIMLAMASI	STATIC VALUE Jx (cm4) / Jy (cm4)
	55-9022/9054	1,500	56 mm OVAL SASH PROFILE 56 mm Oval Kanat Profili	18,49/ 15,71
	**55-9022/9054-P	1,525	56 mm Polyurethane Oval Filled Sash Pr. 56 mm Poliüretan Dolgulu Oval Kanat Profili	
	55-9024/9025	1,850	82 mm SASH PROFILE 82 mm Kanat Profili	25,24 / 39,70
	**55-9024/9025-P	1,905	82 mm Polyurethane Filled Sash Profile 82 mm Poliüretan Dolgulu Kanat Profili	
	55-9027/9004	2,090	39mm MULLION PROFILE (REINFORCEMENT) 39mm Ortakayıt Profili (takviyeli)	62,55/ 17,95
	**55-9027/9004-P	2,115	39 mm Polyurethane Filled Frame Profile (REINFORCEMENT) 39 mm Poliüretan Dolgulu Kasa Pr. (takviyeli)	
	55-9032/9033	1,380	42 mm OVAL FRAME PROFILE 42 mm Oval Kasa Profili	15,59 / 10,41
	**55-9032/9033-P	1,400	42 mm Polyurethane Filled Oval Frame Profile 42 mm Poliüretan Dolgulu Oval Kasa Profili	
	55-11942/11943	1,325	HIDDEN SASH PROFILE Gizli Kanat Profili	13,04 / 8,86
	**55-11942/11943-P	1,340	Polyurethane Filled Hidden Sash Pr. Poliüretan Dolgulu Gizli Kanat Profili	
	55-9052/9053	1,305	135° CORNER ADAPTER PROFILE 135° Köşe Adaptör Profili	11,18 / 5,66
	**55-9052/9053P	1,315	Polyurethane Filled 135° Corner Adapter Pr. Poliüretan Dolgulu 135° Köşe Adaptör Profili	
	*55-9052/9124	1,415	135° CORNER ADAPTER PROFILE 135° Köşe Adaptör Profili	22,02 / 9,11
	**55-9052/9124-P	1,440	Polyurethane Filled 135° Corner Adapter Pr. Poliüretan Dolgulu 135° Köşe Adaptör Profili	
	55-9064/9016	1,475	39 mm Z SHAPE FRAME PROFILE 39 mm Z Kasa Profili	15,57 / 18,73
	**55-9064/9016-P	1,500	39 mm Polyurethane Filled Z Shape Frame Pr. 39 mm Poliüretan Dolgulu Z Kasa Profili	
	55-9065/9066	1,795	16 mm CHANNEL SASH PROFILE 16 mm PVC Kanallı Kanat Profili	28,72 / 26,80
	**55-9065/9066-P	1,820	Polyurethane Filled 16 mm Channel Sash Pr. Poliüretan Dolgulu 16 mm PVC Kanallı Kanat Pr.	
	55-9067/9068	1,790	90° CORNER ADAPTER PROFILE 90° Köşe Adaptör Profili	19,98 / 26,65
	**55-9067/9068-P	1,800	Polyurethane Filled 90° Corner Adapter Pr. Poliüretan Dolgulu 90° Köşe Adaptör Profili	
	*55-9067/9125	2,015	90° CORNER ADAPTER PROFILE 90° Köşe Adaptör Profili	36,07 / 48,10
	**55-9067/9125-P	2,040	Polyurethane Filled 90° Corner Adapter Pr. Poliüretan Dolgulu 90° Köşe Adaptör Profili	

** Sipariş miktarı minimum 100 boydur. / Minimum order quantity: 100 bar

* Sipariş miktarı minimum 600 kg dır. / Minimum orde quantity: 600 kg

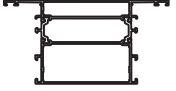
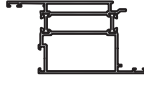
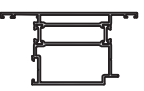
Uyarı: Profil ağırlıklarımız teorik olup; teslim anındaki tartımız geçerlidir.

Warning: the weights of profile is theoretical, weighting at the time of delivery are valid.

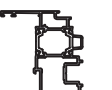
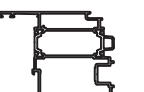
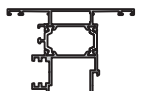











ALUMINIUM PROFILES Alüminyum Profiller				
PROFİL RESMİ DRAWING	PROFİL NO PROFILE NO	AĞIRLIK WEIGHT (kg/m)	DESCRIPTION PROFİL TANIMLAMASI	STATIC VALUE Jx (cm4) / Jy (cm4)
	55-9069/9070	1,250	CIRCULAR CORNER ADAPTER PR. Dairesel Köşe Dönüş Adaptör Profili	11,73 / 8,94
	**55-9069/90708-P	1,275	Polyurethane Filled Circular Corner Adapter Pr. Poliüretan Dolgulu Dairesel Köşe Dönüş Adaptör Pr.	
	55-9093/9012	2,120	78 mm MULLION PROFILE for SASH 78 mm Kanat İçerik Ortakayıt Profili	28,82 / 68,03
	**55-9093/9012-P	2,190	78 mm Polyurethane Filled Mullion Pr. for Sash 78 mm Poliüretan Dolgulu Kanat İçerik Ortakayıt Pr.	
	55-9094/9095	2,035	INSIDE OPENING FLAT DOOR PROFILE İçerik Açılır Hemyüz Kapı Profili	21,72 / 43,63
	**55-9094/9095-P	2,075	Polyurethane Filled Inside Opening Flat Door Pr. Poliüretan Dolgulu İçerik Açılır Hemyüz Kapı Pr.	
	55-9096/9097	2,030	OUTSIDE OPENING FLAT DOOR PROFILE Dışerik Açılır Hemyüz Kapı Profili	20,16 / 42,68
	**55-9096/9097-P	2,070	Polyurethane Filled Outside Opening Flat Door Pr. Poliüretan Dolgulu Dışerik Açılır Hemyüz Kapı Pr.	
	55-9098/9099	1,005	INSIDE OPENING FLAT DOOR ADAPTER PR. İçerik Açılır Hemyüz Kapı Adaptör Profili	6,87 / 3,70
	**55-9098/9099-P	1,010	Polyurethane Filled Inside Opening Flat Door Adapter Pr. Poliüretan Dolgulu İçerik Açılır Hemyüz Kapı Adaptör Pr.	
	55-9101/9102	1,195	OUTSIDE OPENING FLAT DOOR ADAPTER PR. Dışerik Açılır Hemyüz Kapı Adaptör Pr.	10,27 / 6,95
	**55-9101/9102-P	1,210	Polyurethane Filled Outside Opening Flat Door Adapter Pr. Poliüretan Dolgulu Dışerik Açılır Hemyüz Kapı Adaptör Pr.	
	55-9103/9104	1,065	OUTSIDE OPENING DOUBLE SASH ADAP. Dışerik Açılır Çift Kanat Adaptör Pr.	9,04 / 4,04
	**55-9103/9104-P	1,075	Polyurethane Filled Outside Opening Double Sash Adapt. Poliüretan Dolgulu Dışerik Açılır Çift Kanat Adaptör Pr.	
	55-9108/9109	1,000	GLAZING BEAD ADAPTER PR. Cam Çıtası Adaptör Profili	7,55 / 3,24
	**55-9108/9109-P	1,020	Polyurethane Filled Glazing Bead Adapter Pr. Poliüretan Dolgulu Cam Çıtası Adaptör Profili	
	55-9111/91112	1,500	16mm CHANNEL SASH PROFILE Pvc Kanallı Kanat Profili	19,02 / 12,44
	**55-9111/91112-P	1,525	16mm Polyurethane Filled Channel Sash Pr. Poliüretan Dolgulu PVC Kanallı Kanat Pr.	
	55-9113/9114	1,865	16mm CHANNEL SASH PROFILE Pvc Kanallı Kanat Profili	24,82 / 35,17
	**55-9113/9114-P	1,915	16mm Polyurethane Filled Channel Sash Pr. Poliüretan Dolgulu PVC Kanallı Kanat Pr.	
	*55-9118/9119	1,695	PIVOT SASH PROFILE Pivot Kanat Profili	21,24 / 19,78
	**55-9118/9119-P	1,730	Polyurethane Filled Pivot Sash Pr. Poliüretan Dolgulu Pivot Kanat Profili	

** Sipariş miktarı minimum 100 boydur. / Minimum order quantity: 100 bar

* Sipariş miktarı minimum 600 kg dır. / Minimum order quantity: 600 kg

Uyarı: Profil ağırlıklarımız teorik olup; teslim anındaki tartımız geçerlidir.

Warning: the weights of profile is theoretical, weighting at the time of delivery are valid.











ALUMINIUM PROFILES Alüminyum Profiller				
PROFİL RESMİ DRAWING	PROFİL NO PROFILE NO	AĞIRLIK WEIGHT (kg/m)	DESCRIPTION PROFİL TANIMLAMASI	STATIC VALUE Jx (cm4) / Jy (cm4)
	55-9120/9121	1,340	DOUBLE CASEMENT ADAPTER PR. Çift Kanat Adaptör Profili	15,36 / 10,37
	**55-9120/9121-P	1,360	Polyurethane Filled Double Casement Adapter Pr. Poliüretan Dolgulu Çift Kanat Adaptör Profili	
	*55-9005/9126	1,810	26 mm MULLION PROFILE (REINFORCEMENT) 26 mm Ortakayıt Profili (takviyeli)	41,12 / 12,36
	**55-9005/9126-P	1,820	26 mm Polyurethane Filled Frame Profile (REINFORCEMENT) 26 mm Poliüretan Dolgulu Kasa Profili (takviyeli)	
	55-9127/9128	1,375	45 mm FRAME PROFILE 45 mm Oval Kasa Profili	13,10 / 14,41
	**55-9127/9128-P	1,415	45 mm Polyurethane Filled Frame Profile 45 mm Poliüretan Dolgulu Kasa Profili	
	*55-9111/11446	1,415	16mm CHANNEL SASH PROFILE Pvc Kanallı Kanat Profili	20,84 / 17,34
	**55-9111/11446-P	1,440	16mm Polyurethane Filled Channel Sash Pr. Poliüretan Dolgulu PVC Kanallı Kanat Pr.	
	55-9144/9004	1,520	39 mm MULLION PROFILE for SASH 39 mm Kanat İçi Ortakayıt Profili	19,59 / 26,50
	**55-9144/9004-P	1,545	39mm Polyurethane Filled Mullion Profile for Sash 39mm Poliüretan Dolgulu Kanat İçi Ortakayıt Profili	
	877	0,130	ROD PROFILE Tij Profili	-----
	9045	0,280	16,2 mm GLAZING BEAD PROFILE 16,2 mm Cam Çita Profili	-----
	9046	0,265	13,2 mm GLAZING BEAD PROFILE 13,2 mm Cam Çita Profili	-----
	9048	0,340	24,9 mm GLAZING BEAD PROFILE 24,9 mm Cam Çita Profili	-----
	9050	0,360	31,2 mm GLAZING BEAD PROFILE 31,2 mm Cam Çita Profili	-----
	9063	0,245	7,2 mm GLAZING BEAD PROFILE 7,2 mm Cam Çita Profili	-----
	9074	0,300	20,9mm GLAZING BEAD PROFILE 20,9mm Cam Çita Profili	-----

** Sipariş miktarı minimum 100 boydur. / Minimum order quantity: 100 bar

* Sipariş miktarı minimum 600 kg dır. / Minimum orde quantity: 600 kg

Uyarı: Profil ağırlıklarımız teorik olup; teslim anındaki tartımız geçerlidir.











Warning: the weights of profile is theoretical, weighting at the time of delivery are valid.

ALUMINIUM PROFILES Alüminyum Profiller				
PROFİL RESMİ DRAWING	PROFİL NO PROFILE NO	AĞIRLIK WEIGHT (kg/m)	DESCRIPTION PROFİL TANIMLAMASI	STATIC VALUE Jx (cm4) / Jy (cm4)
	9100	0,295	INSIDE OPENING DOOR ADAPTER PROFILE İçe Açılır Kapı Adaptör Profili	-----
	***9117	0,935	ADAPTER for PIVOT SASH Eksenel Kanat için Adaptör Profili	9,47 / 7,34
	9138	0,200	GLAZING BEAD PROFILE for EXTERIOR Dış için Cam Çıta Profili	-----
	***9139	0,875	INTERNAL SILL PROFILE İç Pervaz Profili	-----
	***9140	0,290	ADAPTER PROFILE for SILL Pervaz için Adaptör Profili	-----
	***9141	1,155	139 mm EXTERIOR SILL PROFILE 139 mm Dış Pervaz Profili	-----
	***9142	0,865	REINFORCEMENT PROFILE for MULLION Orta kayıt Takviye Profili	6,07 / 9,66
	***9143	1,770	210 mm EXTERIOR SILL PROFILE 210 mm Dış Pervaz Profili	-----
	11944	0,110	GLAZING BEAD for HIDDEN SASH PROFILE Gizli Kanat için Cam Çıta Profili	-----
	11945	0,310	GLASS SUPPORT for HIDDEN SASH Gizli Kanat için Cam Taşıyıcı	-----

*** Sipariş miktarı minimum 300 kg dir. / Minimum orde quantity: 300 kg

Uyarı: Profil ağırlıklarımız teorik olup; teslim anındaki tartımız geçerlidir.





Warning: the weights of profile is theoretical, weighting at the time of delivery are valid.

ALUMINIUM PROFILES Aluminyum Profiller		2mm THICK PROFILES 2mm Kalın Etli Profiller		
PROFİL RESMİ DRAWING	PROFİL NO PROFILE NO	AĞIRLIK WEIGHT (kg/m)	DESCRIPTION PROFİL TANIMLAMASI	STATIC VALUE Jx (cm4) / Jy (cm4)
	55-9001-B/9002-B	1,370	26 mm MULLION PROFILE 26 mm Ortakayıt Profili	13,13 / 8,67
	**55-9001-B/9002-B-P	1,380	26 mm Polyurethane Filled Mullion Profile 26mm Poliüretan Dolgulu Ortakayıt Profili	
	55-9003-B/9004-B	1,630	39mm MULLION PROFILE 39mm Ortakayıt Profili	16,27 / 16,82
	**55-9003-B/9004-B-P	1,655	39 mm Polyurethane Filled Mullion Profile 39 mm Poliüretan Dolgulu Ortakayıt Profili	
	55-9003-B/9016-B	1,495	39 mm FRAME PROFILE 39 mm Kasa Profili	14,58 / 11,38
	**55-9003-B/9016-B-P	1,520	39 mm Polyurethane Filled Frame Profile 39 mm Poliüretan Dolgulu Kasa Profili	
	55-9003-B/9026-B	2,425	39mm MULLION PROFILE (REINFORCEMENT) 39mm Ortakayıt Profili (takviyeli)	103,46 / 25,18
	**55-9003-B/9026-B-P	2,450	39 mm Polyurethane Filled Frame Profile (REINFORCEMENT) 39 mm Poliüretan Dolgulu Kasa Profili (takviyeli)	
	55-9009-B/9010-B	1,880	52 mm MULLION PROFILE 52 9mm Ortakayıt Profili	19,41 / 29,47
	**55-9009-B/9010-B-P	1,920	52 mm Polyurethane Filled Mullion Profile 52 mm Poliüretan Dolgulu Ortakayıt Profili	
	55-9009-B/9017-B	1,620	52 mm FRAME PROFILE 52 mm Kasa Profili	17,69 / 21,86
	**55-9009-B/9017-B-P	1,660	52 mm Polyurethane Filled Frame Profile 52 mm Poliüretan Dolgulu Kasa Profili	
	55-9022-B/9023-B	1,620	56 mm SASH PROFILE 56 mm Kanat Profili	21,60 / 14,16
	**55-9022-B/9023-B-P	1,645	56 mm Polyurethane Filled Sash Profile 56 mm Poliüretan Dolgulu Kanat Profili	
	55-9024-B/9025-B	2,135	82 mm SASH PROFILE 82 mm Kanat Profili	30,24 / 42,86
	**55-9024-B/9025-B-P	2,190	82 mm Polyurethane Filled Sash Profile 82 mm Poliüretan Dolgulu Kanat Profili	
	55-9027-B/9004-B	2,115	39mm MULLION PROFILE (REINFORCEMENT) 39mm Ortakayıt Profili (takviyeli)	65,19 / 18,15
	**55-9027-B/9004-B-P	2,140	39 mm Polyurethane Filled Frame Profile (REINFORCEMENT) 39 mm Poliüretan Dolgulu Kasa Profili (takviyeli)	
	55-11241/11242	2,195	52 mm MULLION PROFILE (with screw channel) 52 mm Ortakayıt Profili vida kanallı	22,29 / 31,17
	**55-11241/11242-P	2,235	52 mm Polyurethane Filled MULLION PROFILE (with screw channel) 52 mm Poliüretan Dolgulu Ortakayıt Profili (vida kanallı)	

** Sipariş miktarı minimum 100 boydur. / Minimum order quantity: 100 bar

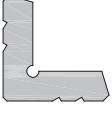
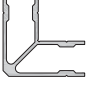
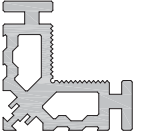
Uyarı: Profil ağırlıklarımız teorik olup; teslim anındaki tartımız geçerlidir.

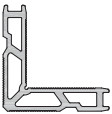
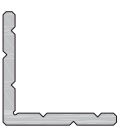
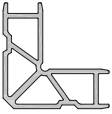
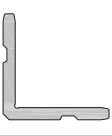
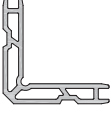
Warning: the weights of profile is theoretical, weighting at the time of delivery are valid.





ALUMINIUM PROFILES Alüminyum Profiller				
PROFİL RESMİ DRAWING	PROFİL NO PROFILE NO	AĞIRLIK WEIGHT (kg/m)	DESCRIPTION PROFİL TANIMLAMASI	STATIC VALUE Jx (cm ⁴) / Jy (cm ⁴)
	338	6,000	19,7mm CORNER CLEAT PROFILE 19,7 mm Köşe Takozu	-----
	1626	0,630	15,5 mm CORNER CLEAT PROFILE 15,5 mm Köşe Bağlantı Profili	-----
	3223	7,070	32,9 mm CORNER CLEAT PROFILE 32,9 mm Köşe Takozu	-----
	3772	6,230	35,8 mm CORNER CLEAT PROFILE 35,8 mm Köşe Takozu	-----
	5541	2,550	15,3 mm CORNER CLEAT PROFILE 15,3 mm Köşe Takozu	-----
	6209	2,910	7,9 mm CORNER CLEAT PROFILE 7,9 mm Köşe Takozu	-----
	9082	2,810	26,2 mm CORNER CLEAT PROFILE 26,2 mm Köşe Takozu	-----
	9083	2,680	8 mm CORNER CLEAT PROFILE 8 mm Köşe Takozu	-----
	9084	2,370	13,2 mm CORNER CLEAT PROFILE 13,2 mm Köşe Takozu	-----
	9085	3,250	21mm CORNER CLEAT PROFILE 21 mm Köşe Takozu	-----
	9086	3,385	39,2 mm CORNER CLEAT PROFILE 39,2 mm Köşe Takozu	-----

Uyarı: Profil ağırlıklarımız teorik olup; teslim anındaki tartımız geçerlidir.

Warning: the weights of profile is theoretical, weighting at the time of delivery are valid.

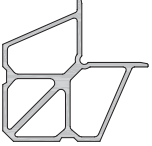
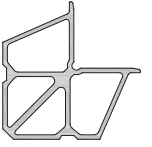
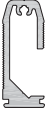
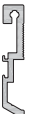
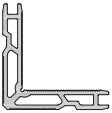
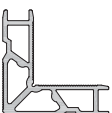
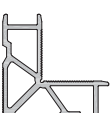
ALUMINIUM PROFILES

Aluminyum Profiller





PROFİL RESMİ DRAWING	PROFİL NO PROFILE NO	AĞIRLIK WEIGHT (kg/m)	DESCRIPTION PROFİL TANIMLAMASI	STATIC VALUE Jx (cm ⁴) / Jy (cm ⁴)
	9087	3,995	19,7mm CORNER CLEAT PROFILE 19,7 mm Köşe Takozu	-----
	9088	3,785	15,5 mm CORNER CLEAT PROFILE 15,5 mm Köşe Bağlantı Profili	-----
	9089	0,870	T-CONNECTOR PROFILE Dik Bağlantı Profili	-----
	9090	0,530	T-CONNECTOR PROFILE Dik Bağlantı Profili	-----
	9132	2,330	12,8 mm CORNER CLEAT PROFILE 12,8 mm Köşe Takozu	-----
	9133	2,715	20,3 mm CORNER CLEAT PROFILE 20,3 mm Köşe Takozu	-----
	9134	2,835	25,8 mm CORNER CLEAT PROFILE 25,8 mm Köşe Takozu	-----
	9135	4,945	38,8 mm CORNER CLEAT PROFILE 38,8 mm Köşe Takozu	-----
	9136	4,030	46,3 mm CORNER CLEAT PROFILE 46,3 mm Köşe Takozu	-----
	9137	4,240	51,8 mm CORNER CLEAT PROFILE 51,8 mm Köşe Takozu	-----





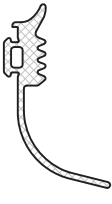

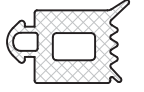
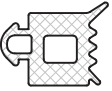
Uyarı: Profil ağırlıklarımız teorik olup; teslim anındaki tartımız geçerlidir.

Warning: the weights of profile is theoretical, weighting at the time of delivery are valid.

**EW55
WINDOWS and DOORS
SYSTEM
GASKETS and ACCESSORIES**



**EW55 KAPI ve PENCERE
SİSTEMİ
CONTA ve AKSESUARLAR**

GASKETS Contalar				
DRAWING PROFİL RESMİ	CODE NUMARA	MATERIAL MALZEME	DESCRIPTION MALZEME TANIMI	PACKAGING AMBALAJ
	SC 103-1	Epdm	EXTERIOR GLAZING GASKET (h:4,6mm) Dış cam contası (boşluk : 4,6mm)	250mt/pk
	SC 108-1	Epdm	EXTERIOR GLAZING GASKET WITH FLAP (h:4,6mm) Perdeli dış cam contası (boşluk : 4,6mm)	150mt/pk
	SC 113	Epdm	EXTERIOR OVERLAP GASKET Dış bini contası	800mt/pk
	SC 119	Epdm	EXTERIOR OVERLAP GASKET Dış bini contası	500mt/pk
	SC 203	Epdm	INTERIOR GLAZING GASKET for HIDDEN SASH (h:11mm) Gizli kanat iç cam contası (boşluk : 11mm)	125mt/pk
	SC 204	Epdm	INTERIOR GLAZING GASKET for HIDDEN SASH (h:9mm) Gizli kanat iç cam contası (boşluk : 9mm)	150mt/pk
	SC 205	Epdm	INTERIOR GLAZING GASKET for HIDDEN SASH (h:7mm) Gizli kanat iç cam contası (boşluk : 7mm)	200mt/pk

GASKETS Contalar				
DRAWING PROFİL RESMİ	CODE NUMARA	MATERIAL MALZEME	DESCRIPTION MALZEME TANIMI	PACKAGING AMBALAJ
	SC 206	Epdm	INTERIOR GLAZING GASKET for HIDDEN SASH (h:5mm) Gizli kanat iç cam contası (boşluk : 5mm)	220mt/pk
	SC 207	Epdm	INTERIOR GLAZING GASKET for HIDDEN SASH (h:3mm) Gizli kanat iç cam contası (boşluk : 3mm)	330mt/pk
	SC 208	Epdm	EXTERIOR GLAZING GASKET for HIDDEN SASH Gizli kanat dış cam contası	85mt/pk
	SC 227	Epdm	INTERIOR OVERLAP GASKET İç bini contası	300mt/pk
	SC 228	Epdm	CENTRAL GASKET Merkezi tozluk contası	90mt/pk
	SC 229	Epdm	INTERIOR GLAZING GASKET (h:4-5mm) İç cam contası (boşluk : 4-5mm)	185mt/pk
	SC 282	Epdm	INTERIOR GLAZING GASKET (h:8-9mm) İç cam contası (boşluk : 8-9mm)	165mt/pk

GASKETS

Contalar

DRAWING PROFİL RESMİ	CODE NUMARA	MATERIAL MALZEME	DESCRIPTION MALZEME TANIMI	PACKAGING AMBALAJ
	SC 284	Epdm	INTERIOR GLAZING GASKET (h:6-7mm) İç cam contası (boşluk : 6-7mm)	185mt/pk
	SC 287	Epdm	EXTERIOR OVERLAP GASKET Dış bini contası	300mt

ACCESSORIES

Aksesuarlar

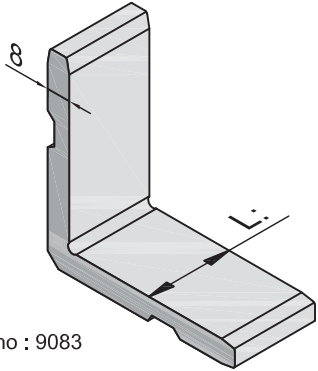
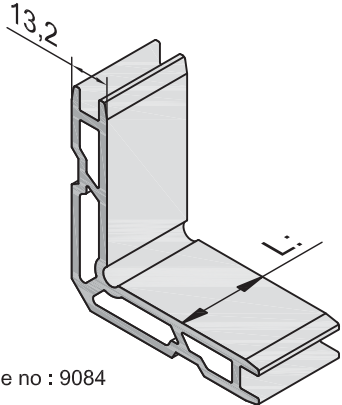
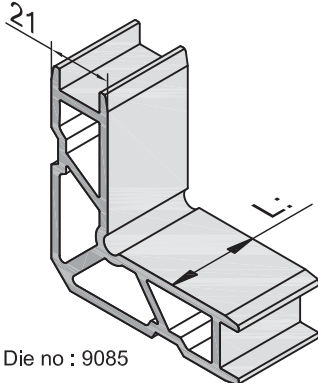
DRAWING PROFİL RESMİ	CODE NUMARA	DESCRIPTION MALZEME TANIMI	PACKAGING AMBALAJ
 <p>Die no : 9083</p>	SC 001	L:5,2mm (9020-9021/9020-9030/9020-9036 ile kullanılır)	50 pieces 50 adet
 <p>Die no : 9084</p>	SC 002	L:9,8mm (9001-9015/9001-9002/9001-9028/ 9001-9035/9001-9059/ 9001-9034 ile kullanılır)	50 pieces 50 adet
	SC 003	L:18,8mm (9001-9015/9001-9002/9001-9028/ 9001-9035/9001-9059/ 9001-9034 ile kullanılır)	
	SC 004	L:27,8mm (9020-9021/9020-9030/9020-9036 ile kullanılır)	
 <p>Die no : 9085</p>	SC 005	L:5,2mm (9022-9023/9022-9031/9022-9054 ile kullanılır)	50 pieces 50 adet

ACCESSORIES

Aksesuarlar

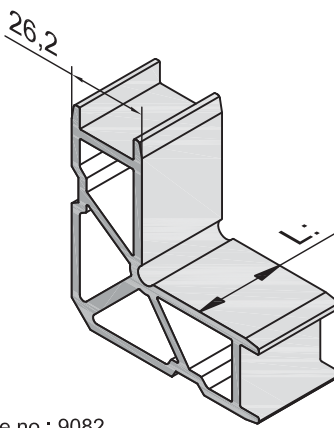
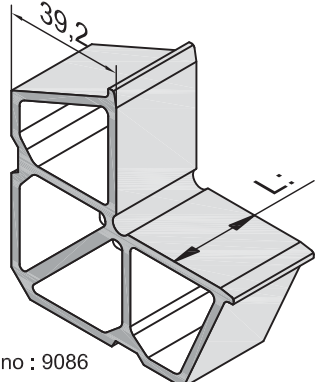
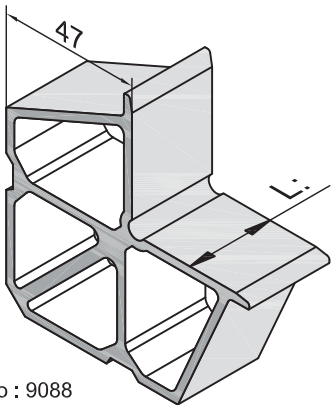
DRAWING PROFİL RESMİ	CODE NUMARA	DESCRIPTION MALZEME TANIMI	PACKAGING AMBALAJ
 <p>Die no : 9082</p>	SC 006	L:5,2mm (9065-9066 ile kullanılır)	50 pieces 50 adet
	SC 007	L:9,8mm (9003-9016/9064-9016/9003-9004/ 9003-9029 ile kullanılır)	
	SC 008	L:18,8mm (9003-9016/9064-9016/9003-9004/ 9003-9029 ile kullanılır)	
	SC 009	L:27,8mm (9022-9023/9022-9031/9022-9054 ile kullanılır)	
	SC 010	L:35,6mm (9065-9066 ile kullanılır)	
 <p>Die no : 9086</p>	SC 011	L:9,8mm (9009-9017/9009-9010 ile kullanılır)	50 pieces 50 adet
	SC 012	L:18,8mm (9009-9017/9009-9010 ile kullanılır)	
 <p>Die no : 9088</p>	SC 013	L:5,2mm (9024-9025/9094-9095 ile kullanılır)	50 pieces 50 adet

ACCESSORIES

Aksesuarlar

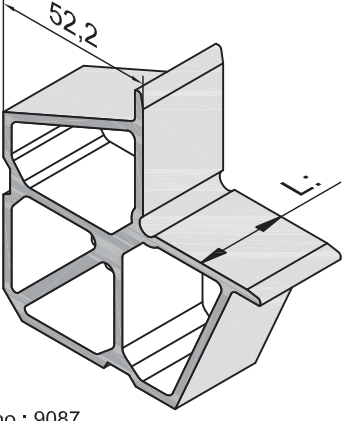
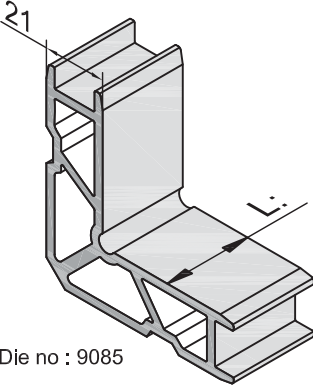
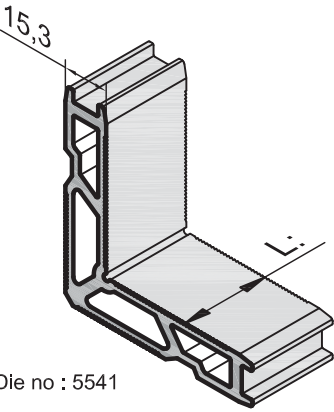
DRAWING PROFİL RESMİ	CODE NUMARA	DESCRIPTION MALZEME TANIMI	PACKAGING AMBALAJ
 <p>Die no : 9087</p>	SC 014	L:27,8mm (9024-9025 ile kullanılır)	50 pieces 50 adet
	SC 015	L:21,5mm (9096-9097 ile kullanılır)	
	SC 016	L:27,1mm (9094-9095 ile kullanılır)	
	SC 017	L:5,3mm (9096-9097 ile kullanılır)	
 <p>Die no : 9085</p>	SC 026	L:18,8mm (9032-9033 ile kullanılır)	50 pieces 50 adet
	SC 027	L:17,8mm (9032-9033 ile kullanılır)	
 <p>Die no : 5541</p>	SC 028	L:5,2mm (9111-9112 ile kullanılır)	50 pieces 50 adet
	SC 029	L:27,8mm (9111-9112/9111-11446 ile kullanılır)	

ACCESSORIES

Aksesuarlar

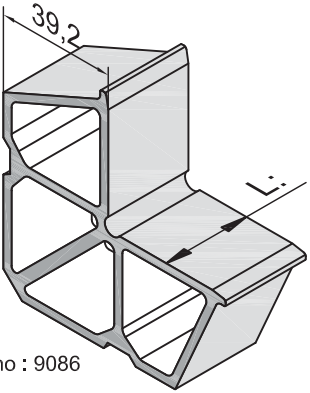
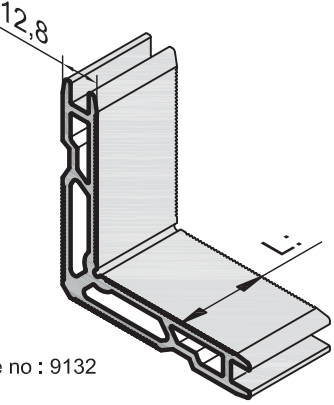
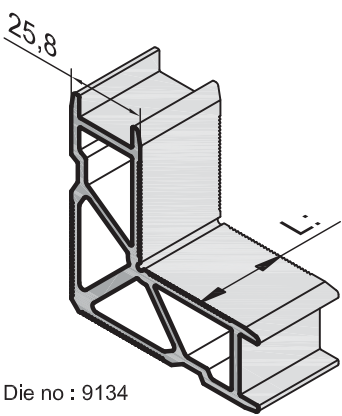
DRAWING PROFİL RESMİ	CODE NUMARA	DESCRIPTION MALZEME TANIMI	PACKAGING AMBALAJ
 <p>Die no : 9086</p>	SC 060	L:5,2mm (9113-9114 ile kullanılır)	50 pieces 50 adet
	SC 061	L:27,8mm (9113-9114 ile kullanılır)	
 <p>Die no : 9132</p>	SC 062	L:9,1mm (9001-B / 9002-B ile kullanılır)	50 pieces 50 adet
	SC 063	L:18,2mm (9001-B / 9002-B ile kullanılır)	
 <p>Die no : 9134</p>	SC 064	L:9,2mm (9003B-9016B / 9003B-9004B ile kullanılır)	50 pieces 50 adet
	SC 065	L:18,2mm (9003B-9016B / 9003B-9004B ile kullanılır)	

ACCESSORIES
Aksesuarlar

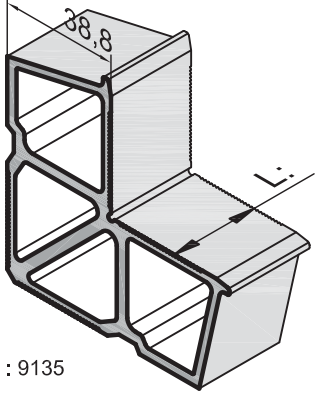
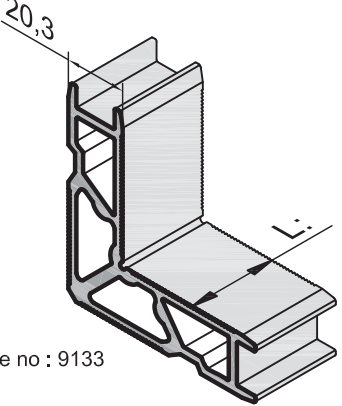
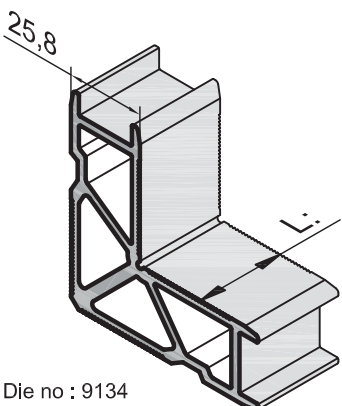
DRAWING PROFİL RESMİ	CODE NUMARA	DESCRIPTION MALZEME TANIMI	PACKAGING AMBALAJ
 <p>Die no : 9135</p>	SC 066	L:9,2mm (9009B-9017B / 9009B-9010B ile kullanılır)	50 pieces 50 adet
	SC 067	L:18,2mm (9009B-9017B / 9009B-9010B ile kullanılır)	
 <p>Die no : 9133</p>	SC 068	L:5,2mm (9022-B / 9023-B ile kullanılır)	50 pieces 50 adet
 <p>Die no : 9134</p>	SC 069	L:27,2mm (9022-B / 9023-B ile kullanılır)	50 pieces 50 adet

ACCESSORIES

Aksesuarlar

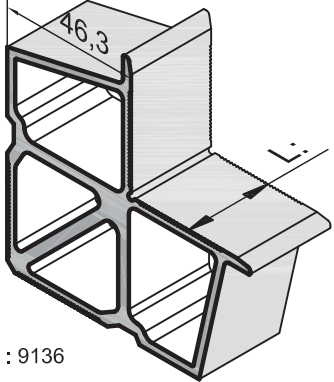
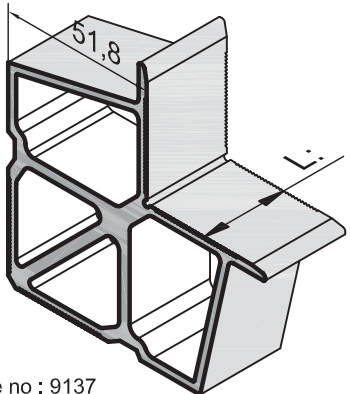
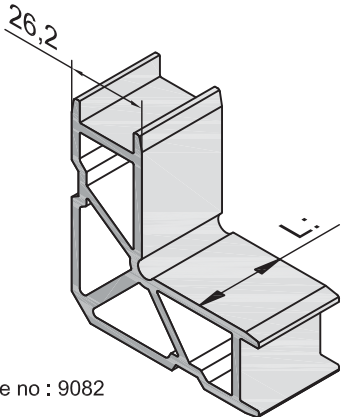
DRAWING PROFİL RESMİ	CODE NUMARA	DESCRIPTION MALZEME TANIMI	PACKAGING AMBALAJ
 <p>Die no : 9136</p>	SC 070	L:5,2mm (9024-B / 9025-B ile kullanılır)	50 pieces 50 adet
 <p>Die no : 9137</p>	SC 071	L:27,2mm (9024-B / 9025-B ile kullanılır)	50 pieces 50 adet
 <p>Die no : 9082</p>	SC 072	L:8,5mm (9018-9019 ile kullanılır)	50 pieces 50 adet
	SC 073	L:28,8mm (9018-9019 ile kullanılır)	

ACCESSORIES

Aksesuarlar

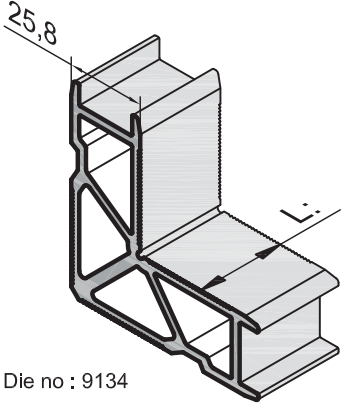
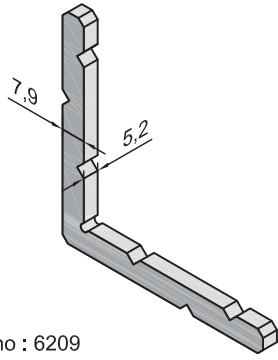
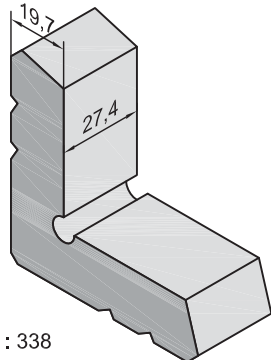
DRAWING PROFİL RESMİ	CODE NUMARA	DESCRIPTION MALZEME TANIMI	PACKAGING AMBALAJ
 <p>Die no : 9134</p>	SC 074	L:28,6mm (9117 ile kullanılır)	50 pieces 50 adet
 <p>Die no : 6209</p>	SC 209	L:5,2mm (11942 / 11943 ile kullanılır)	50 pieces 50 adet
 <p>Die no : 338</p>	SC 213	L:27,4mm (11942 / 11943 ile kullanılır)	50 pieces 50 adet

ACCESSORIES



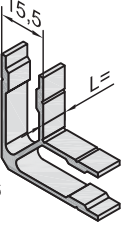
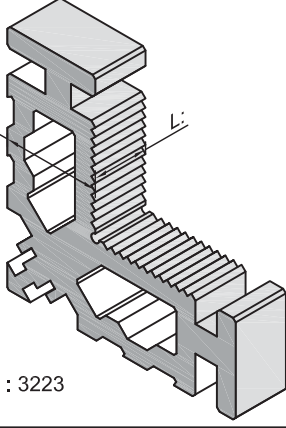
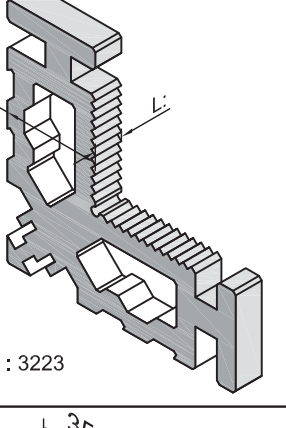
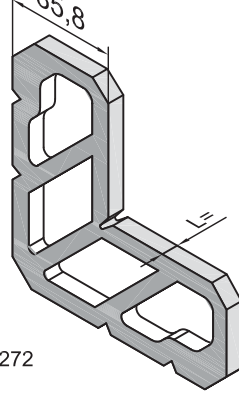



Aksesuarlar

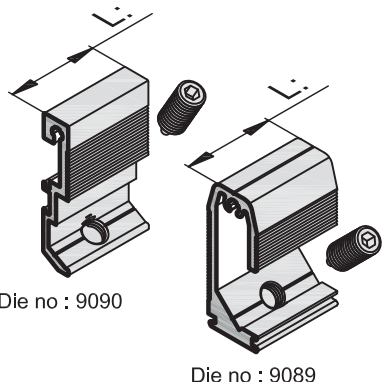

DRAWING PROFİL RESMİ	CODE NUMARA	DESCRIPTION MALZEME TANIMI	PACKAGING AMBALAJ
 <p>Die no : 1626</p>	SC 214	L:8,1mm (11942 / 11943 ile kullanılır)	50 pieces 50 adet
 <p>Die no : 3223</p>	SC 217	L:18,8mm (9127 / 9128 ile kullanılır)	50 pieces 50 adet
 <p>Die no : 3223</p>	SC 218	L:9,8mm (9127 / 9128 ile kullanılır)	50 pieces 50 adet
 <p>Die no : 3272</p>	SC - 286	L:5,6mm (55 - 9111 / 11446)	50 pieces 50 adet

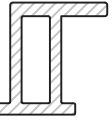

ACCESSORIES

Aksesuarlar

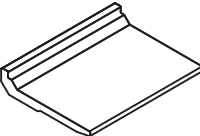
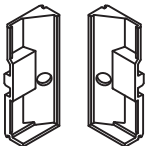
DRAWING PROFİL RESMİ	CODE NUMARA	DESCRIPTION MALZEME TANIMI	PACKAGING AMBALAJ
 <p>Die no : 9090</p> <p>Die no : 9089</p>	SC 030	L:13,2mm "9001/9002-9001/9015-9001/9028- 9001/9034 9001/9035" profilleri ile kullanılır.	50 pieces 50 adet
	SC 031	L:26,2mm "9003/9004-9003/9016-9003/9026 9003/9029-9027/9004" profilleri ile kullanılır	
	SC 032	L:39,2mm 9009/9010 - 9009/9017 profilleri ile kullanılır.	
	SC 033	L:65,2mm 9011/9012 - 9093/9012 profilleri ile kullanılır.	
	SC 034	L:104,2mm 9013/9014 profilleri ile kullanılır.	
	SC 035	L:21mm 9032/9033 profilleri ile kullanılır.	
	SC 036	L:12,8mm 9001-B/9002-B profilleri ile kullanılır.	
	SC 037	L:25,8mm 9027-B/9003-B ve 9004-B profilleri ile kullanılır.	
	SC 038	L:38,8mm 9010-B / 9009-B profilleri ile kullanılır.	

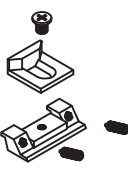
ACCESSORIES Aksesuarlar				
DRAWING PROFİL RESMİ	CODE NUMARA	MATERIAL MALZEME	DESCRIPTION MALZEME TANIMI	PACKAGING AMBALAJ
	SC 040	Alu. / grey gri / alüminyum	SASH and FRAME CORNER JOINT Kanat ve Kasa köşe birleşim onbaşı	500 pieces 500 adet
	SC 041	Pvc - Black Siyah - plastik	SLOPED SYNTHETIC BLOCK INSIDE OPENING WINDOW İçe açılır kanat için kaldırma takozu	25 pieces 25 adet
	SC 042	Alu. / grey gri / alüminyum	SASH CORNER JOINT Kanat köşe birleşim onbaşı	500 pieces 500 adet
	SC 043	Alu. / grey gri / alüminyum	SASH CORNER JOINT Kanat köşe birleşim onbaşı	500 pieces 500 adet
	SC 046	Alu. / grey gri / alüminyum	JAMB CORNER JOINT Pervaz köşe birleşim onbaşı	500 pieces 500 adet
	SC 112	Epdm - Black Siyah - kauçuk	CENTRAL GASKET VULCANIZED CORNER Merkezi tozluk contası köşe dönüş parçası	50 pieces 50 adet
	SC 121	Pvc - Black Siyah - plastik	ADAPTEUR PROFILE for PIVOT Eksenel pencere Adaptör plastik profili	150mt 50pieces x 3mt

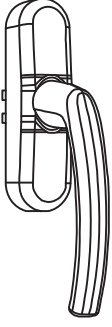
ACCESSORIES Aksesuarlar				
DRAWING PROFİL RESMİ	CODE NUMARA	MATERIAL MALZEME	DESCRIPTION MALZEME TANIMI	PACKAGING AMBALAJ
	PV 24	Pvc - Black Siyah - plastik	40x15 INSULATION U for SUBFRAME Körkasa için 40x15 yalıtım u	150mt 50pieces x 3mt
 Die no : 11945	SC 215	Alu. / grey gri / alüminyum	GLASS SUPPORT for HIDDEN SASH Gizli Kanat için Cam Taşıyıcı	50 pieces 50 adet
	SC 216	Zamak Zamak	FIXED FRAME T-JOINT COUPLE Sabit dograma kasası T bağlantı parçası	50 pieces 50 adet
	SC 220-0	Alu. / grey gri / alüminyum	LOCK DEVICE for ROLLER Makaralı kilit karşılığı (white painted - beyaz boyalı)	the amount of demand talep miktarı
	SC 220-1		LOCK DEVICE for ROLLER Makaralı kilit karşılığı (bright-opaque anodising - parlak-mat eloxa)	
	SC 220-2		LOCK DEVICE for ROLLER Makaralı kilit karşılığı (special colors - özel renkler)	
	SC 221-0	Alu. / grey gri / alüminyum	LOCK DEVICE for CYLINDER Dilli kilit karşılığı (white painted - beyaz boyalı)	the amount of demand talep miktarı
	SC 221-1		LOCK DEVICE for CYLINDER Dilli kilit karşılığı (bright-opaque anodising - parlak-mat eloxa)	
	SC 221-2		LOCK DEVICE for CYLINDER Dilli kilit karşılığı (special colors - özel renkler)	
	SC 222	Zamak Zamak	ADJUSTABLE LOCKING DEVICE Ayarlanabilir kilit karşılığı	50 pieces 50 adet

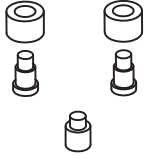
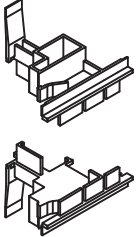
ACCESSORIES Aksesuarlar				
DRAWING PROFİL RESMİ	CODE NUMARA	MATERIAL MALZEME	DESCRIPTION MALZEME TANIMI	PACKAGING AMBALAJ
	SC 230	Alu. / grey gri / alüminyum	AXIAL HANDLE (white painted) EKSENEL KOL (beyaz boyalı)	5 pieces 5 adet
	SC 231		AXIAL HANDLE (anodising) EKSENEL KOL (eloksal)	
	SC 232		AXIAL HANDLE (special color) EKSENEL KOL (özel renk)	
	SC 250	Alu. / grey gri / alüminyum	SLIDING BUILT-IN (savio) Gömme Sürgü (savio) (white painted - beyaz boyalı)	5 pieces 5 adet
	SC 251		SLIDING BUILT-IN (savio) Gömme Sürgü (savio) (anodising - eloksal)	
	SC 252		SLIDING BUILT-IN (savio) Gömme Sürgü (savio) (special colors - özel renkler)	
	SC 260	Pvc Black&White Plastik	WATER DRAINAGE CAP Su tahliye kapagı	500 pieces 500 adet
	SC 270	Siyah veya Beyaz	WATER DRAINAGE CAP Perdeli Su tahliye kapagı	
	SC 261	Steel / yellow sarı / çelik	LOCKING DEVICE PIECES İspanyolet tij pimleri	100 pieces 100 adet
	SC 262	Pvc - Black Siyah - plastik	TWO WINGS WINDOWS ADAPTEUR PLUGS (use with 9018-9019) Çift kanatlı pencere adaptör kapagı (9018-9019 ile kullanılır)	50 pieces 50 adet

ACCESSORIES

Aksesuarlar

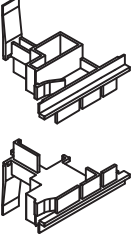
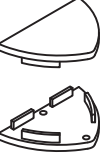
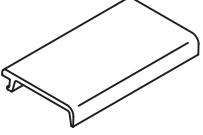
DRAWING PROFİL RESMİ	CODE NUMARA	MATERIAL MALZEME	DESCRIPTION MALZEME TANIMI	PACKAGING AMBALAJ
	SC 264	Pvc - Black Siyah - plastik	CORNER CLEAT Use with 9139-9141 Köşe onbaşı (9139-9141 Profili ile kullanılır)	100 pieces 100 adet
	SC 266	Pvc - Black Siyah - plastik	TWO WINGS WINDOWS ADAPTEUR PLUGS (use with 9120-9121) Çift kanatlı pencere adaptör kapığı (9120-9121 ile kullanılır)	50 pieces 50 adet
	SC 267	Pvc - Black Siyah - plastik	CAP for FINISHING HEADER Use with 9142 profile Profil bitimi için kapak 9142 profili ile kullanılır	100 pieces 100 adet
	SC 302	Pvc - Black Siyah - plastik	GLASS CARRIER BLOCK for FIXED FRAME Sabit pencere için cam taşıyıcı takoz	50 pieces 50 adet

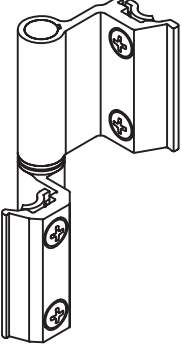
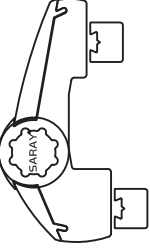
ACCESSORIES Aksesuarlar				
DRAWING PROFİL RESMİ	CODE NUMARA	MATERIAL MALZEME	DESCRIPTION MALZEME TANIMI	PACKAGING AMBALAJ
	SC 800	Alu. / grey gri / alüminyum	WINDOW HINGE white painted,opaque anodising PENCERE MENTEŞESİ beyaz boyalı+ mat eloksal	10 pieces 10 adet
	SC 801		WINDOW HINGE bright anodising PENCERE MENTEŞESİ parlak eloksal	
	SC 802		WINDOW HINGE black anodising PENCERE MENTEŞESİ siyah eloksal	
	SC 803		WINDOW HINGE special colors PENCERE MENTEŞESİ özel renkler	
	SC 804	Alu. / grey gri / alüminyum	REBATED DOOR HINGE white painted,opaque anodising BİNİLİ KAPI MENTEŞESİ beyaz boyalı+ mat eloksal	6 pieces 6 adet
	SC 805		REBATED DOOR HINGE bright anodising BİNİLİ KAPI MENTEŞESİ parlak eloksal	
	SC 806		REBATED DOOR HINGE black anodising BİNİLİ KAPI MENTEŞESİ siyah eloksal	
	SC 807		REBATED DOOR HINGE special colors BİNİLİ KAPI MENTEŞESİ özel renkler	

ACCESSORIES

Aksesuarlar

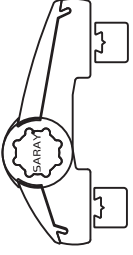
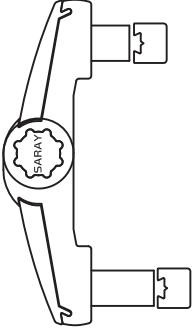
DRAWING PROFİL RESMİ	CODE NUMARA	MATERIAL MALZEME	DESCRIPTION MALZEME TANIMI	PACKAGING AMBALAJ
	SC 808	Alu. / grey gri / alüminyum	FLAT DOOR HINGE white painted,opaque anodising HEMYÜZ KAPI MENTEŞESİ beyaz boyalı+ mat eloksal	6 pieces 6 adet
	SC 809		FLAT DOOR HINGE bright anodising HEMYÜZ KAPI MENTEŞESİ parlak eloksal	
	SC 810		FLAT DOOR HINGE black anodising HEMYÜZ KAPI MENTEŞESİ siyah eloksal	
	SC 811		FLAT DOOR HINGE special colors HEMYÜZ KAPI MENTEŞESİ özel renkler	
	SC 812	Alu. / grey gri / alüminyum	FLAT DOOR HINGE white painted,opaque anodising HEMYÜZ KAPI MENTEŞESİ beyaz boyalı+ mat eloksal	6 pieces 6 adet
	SC 813		FLAT DOOR HINGE bright anodising HEMYÜZ KAPI MENTEŞESİ parlak eloksal	
	SC 814		FLAT DOOR HINGE black anodising HEMYÜZ KAPI MENTEŞESİ siyah eloksal	
	SC 815		FLAT DOOR HINGE special colors HEMYÜZ KAPI MENTEŞESİ özel renkler	

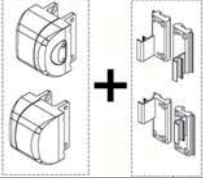
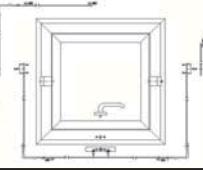
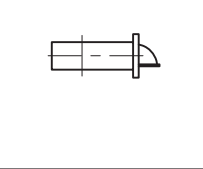
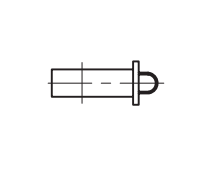
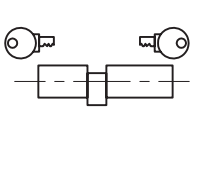
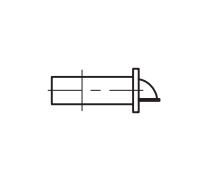
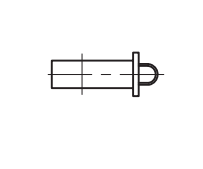
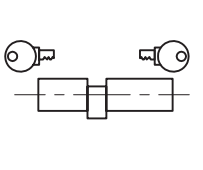
ACCESSORIES Aksesuarlar				
DRAWING PROFİL RESMİ	CODE NUMARA	MATERIAL MALZEME	DESCRIPTION MALZEME TANIMI	PACKAGING AMBALAJ
	SC 820	Alu. / grey gri / alüminyum	PIVOT HINGE (giesse) Eksenel Menteşe	1 Set 2piece hinge 1 takım 2ad menteşe
	SC 821	Alu. / grey gri / alüminyum	PERIPHERAL LOCKING SET for PIVOT (include handle) Eksenel için Çevre kitleme seti (kol dahil)	1 Set 1 takım
	SC 850	Steel Çelik	REBATED DOOR LOCK (153 U 30) DİLLİ KAPI KİLİDİ	30 pieces 30 adet
	SC 851	Steel Çelik	ROLLER DOOR LOCK (155 U 30) MAKARALI KAPI KİLİDİ	30 pieces 30 adet
	SC 852	Steel Çelik	CYLINDER (26+10+35) BAREL	24 pieces 24 adet
	SC 853	Steel Çelik	REBATED DOOR LOCK (153 U 35) DİLLİ KAPI KİLİDİ	30 pieces 30 adet
	SC 854	Steel Çelik	ROLLER DOOR LOCK (155 U 35) MAKARALI KAPI KİLİDİ	30 pieces 30 adet
	SC 855	Steel Çelik	CYLINDER (26+10+45) BAREL	24 pieces 24 adet

**EW55
WINDOWS and DOORS
SYSTEM
FULL SCALE SECTIONS**

**EW55 KAPI ve PENCERE
SİSTEMİ
1:1 ÖLÇEKLİ PROFİL KESİTLERİ**

Full Scale Sections

Tam Ölçekli Profil Kesitleri

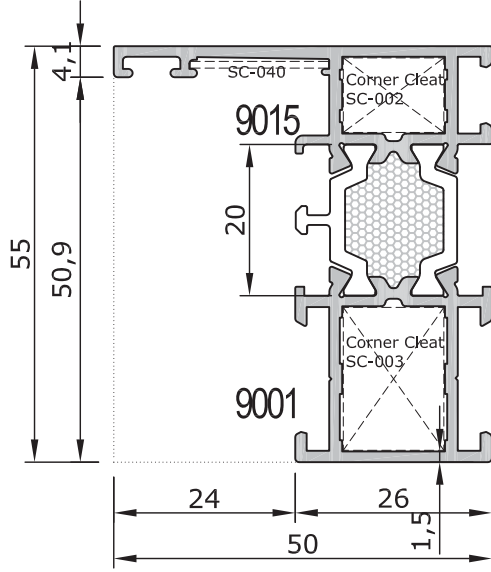
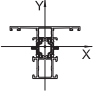

55-9001/9015	26 mm Kasa Profili
1.140 kg/m	26 mm Frame Profile
$J_x=10,04 \text{ cm}^4$	$J_y=4,86 \text{ cm}^4$

55-9001/9015-P	26 mm Poliüretan Dolgulu Kasa Profili
1.150 kg/m	26 mm Polyurethane Filled Frame Profile
$J_x=10,04 \text{ cm}^4$	$J_y=4,86 \text{ cm}^4$

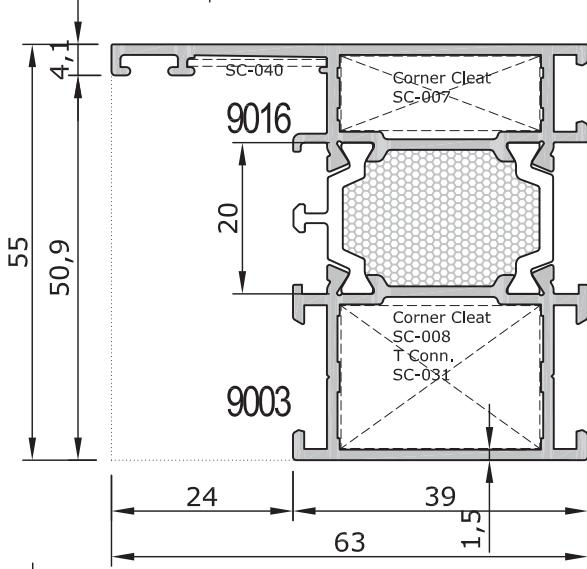

55-9003/9016	39 mm Kasa Profili
1.335 kg/m	39 mm Frame Profile
$J_x=12,30 \text{ cm}^4$	$J_y=10,75 \text{ cm}^4$

55-9003/9016-P	39 mm Poliüretan Dolgulu Kasa Profili
1.360 kg/m	39 mm Polyurethane Filled Frame Profile
$J_x=12,30 \text{ cm}^4$	$J_y=10,75 \text{ cm}^4$

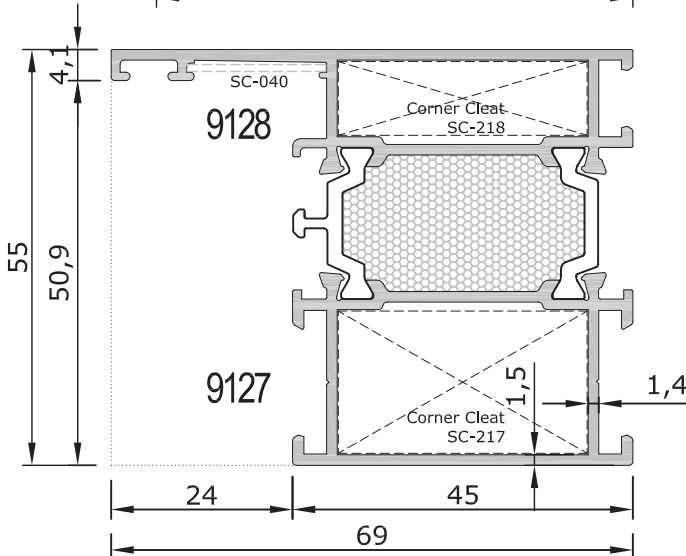

55-9127/9128	45 mm Kasa Profili
1.375 kg/m	45 mm Frame Profile
$J_x=13,10 \text{ cm}^4$	$J_y=14,41 \text{ cm}^4$

55-9127/9128-P	45 mm Poliüretan Dolgulu Kasa Profili
1.410 kg/m	45 mm Polyurethane Filled Frame Profile
$J_x=13,10 \text{ cm}^4$	$J_y=14,41 \text{ cm}^4$

Dikkat: Poliüretan doldurulmuş profiller talep üzerine yapılır.
Minimum sipariş miktarı her bir profil için 100 boydur.
Warning: Polyurethane infilling is made on request
Minimum order quantity: 100 bar

Uyarı: Profil ağırlıklarımız teorik olup; teslim anındaki tartımız geçerlidir.
Warning: the weights of profile is theoretical, weighting at the time of delivery are valid.

Full Scale Sections

Tam Ölçekli Profil Kesitleri

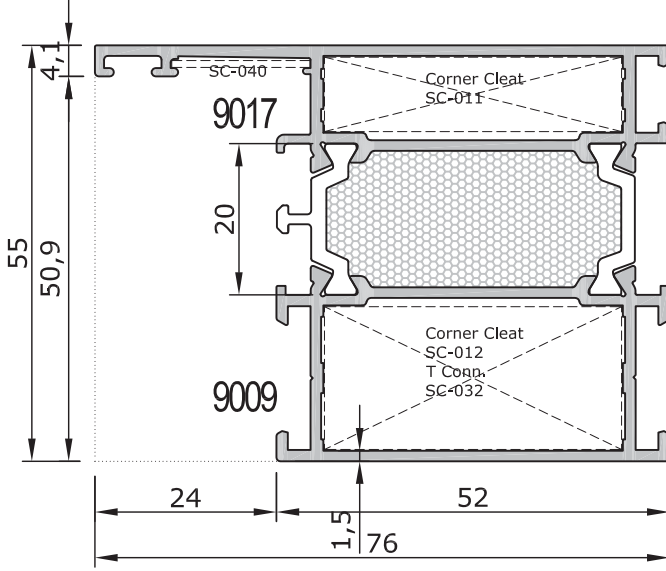
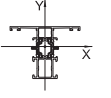

55-9009/9017	52 mm Kasa Profili
1.535 kg/m	52 mm Frame Profile
$J_x=14,56 \text{ cm}^4$	$J_y=20,26 \text{ cm}^4$

55-9009/9017-P	52 mm Poliüretan Dolgulu Kasa Profili
1.575 kg/m	52 mm Polyurethane Filled Frame Profile
$J_x=14,56 \text{ cm}^4$	$J_y=20,26 \text{ cm}^4$

Uyarı: Profil ağırlıklarımız teorik olup; teslim anındaki tartımız geçerlidir.
Warning: the weights of profile is theoretical, weighting at the time of delivery are valid.

Dikkat: Poliüretan doldurulmuş profiller talep üzerine yapılır.
Minimum sipariş miktarı her bir profil için 100 boydur.
Warning: Polyurethane infilling is made on request
Minimum order quantity: 100 bar

Full Scale Sections (2mm Thick Profiles) Tam Ölçekli Profil Kesitleri (2mm Kalın Profiller)

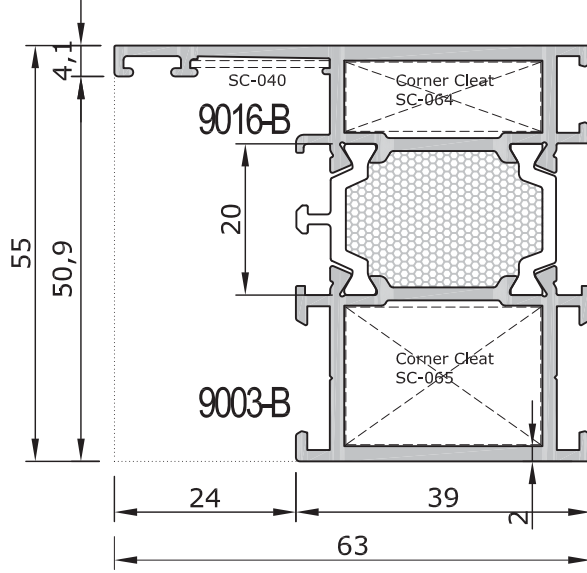
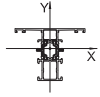

55-9003-B/9016-B	39 mm Kasa Profili
1.495 kg/m	39 mm Frame Profile
$J_x=14,58 \text{ cm}^4$	$J_y=11,38 \text{ cm}^4$

55-9003-B/9016-B-P	39 mm Poliüretan Dolgulu Kasa Profili
1.520 kg/m	39 mm Polyurethane Filled Frame Profile
$J_x=14,58 \text{ cm}^4$	$J_y=11,38 \text{ cm}^4$

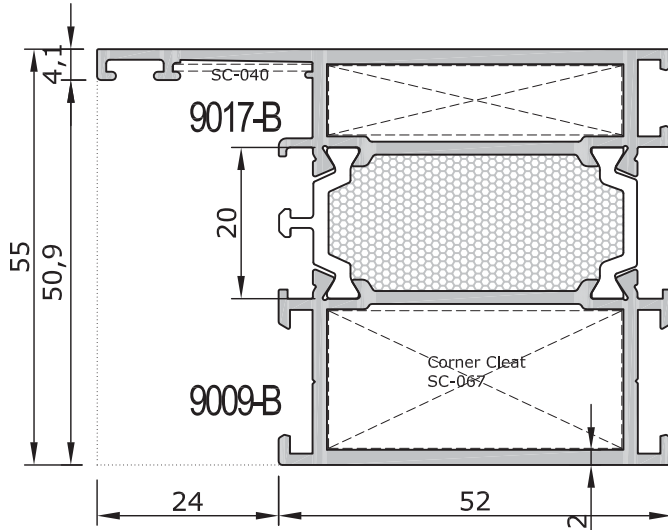

55-9009-B/9017-B	52 mm Kasa Profili
1.620 kg/m	52 mm Frame Profile
$J_x=17,69 \text{ cm}^4$	$J_y=21,86 \text{ cm}^4$

55-9009-B/9017-B-P	52 mm Poliüretan Dolgulu Kasa Profili
1.660 kg/m	52 mm Polyurethane Filled Frame Profile
$J_x=17,69 \text{ cm}^4$	$J_y=21,86 \text{ cm}^4$

Dikkat: Poliüretan doldurulmuş profiller talep üzerine yapılır.
Minimum sipariş miktarı her bir profil için 100 boydur.
Warning: Polyurethane infilling is made on request
Minimum order quantity: 100 bar

Uyarı: Profil ağırlıklarımız teorik olup; teslim anındaki tartımız geçerlidir.
Warning: the weights of profile is theoretical, weighting at the time of delivery are valid.

Full Scale Sections

Tam Ölçekli Profil Kesitleri

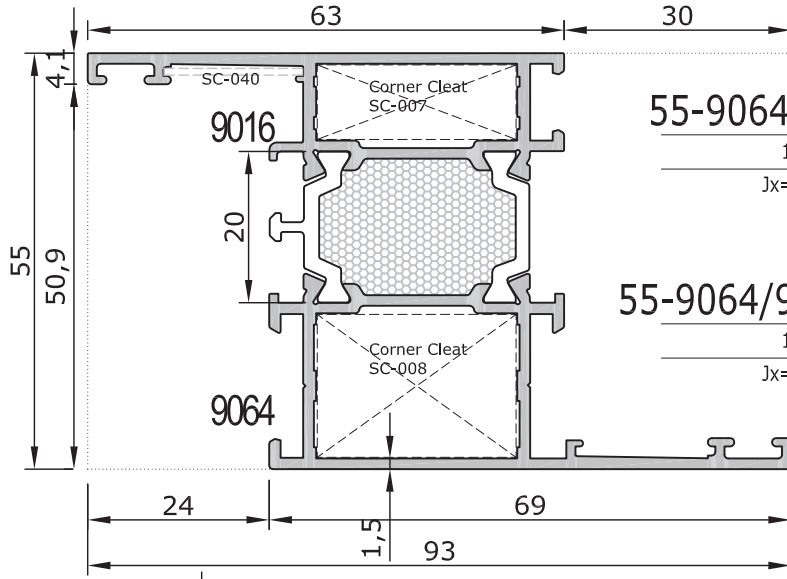
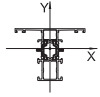

55-9064/9016 Z Kasa Profili

1.475 kg/m Z Frame Profile

Jx=15,57 cm⁴ Jy=18,73 cm⁴

55-9064/9016-P Poliüretan Dolgulu Z Kasa Profili

1.500 kg/m Polyurethane Filled Z Frame Profile

Jx=15,57 cm⁴ Jy=18,73 cm⁴

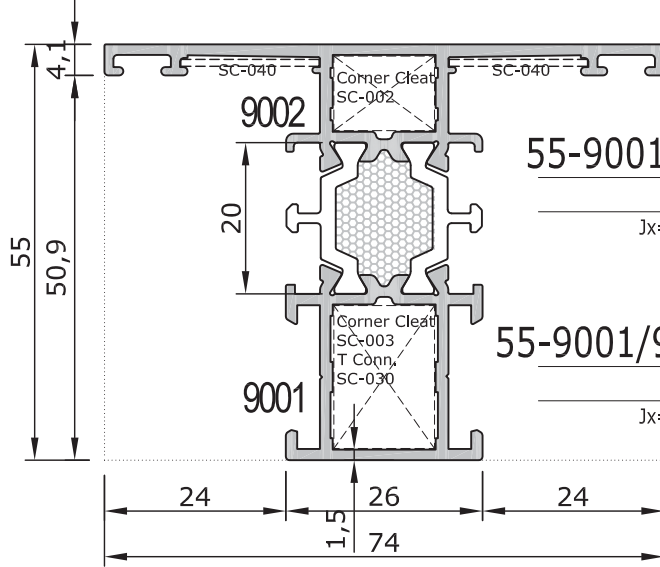

55-9001/9002 26 mm Orta Kayıt Pr.

1.265 kg/m 26 mm Mullion Profile

Jx=11,56 cm⁴ Jy=8,55 cm⁴

55-9001/9002-P 26 mm Poliüretan Dolgulu Orta Kayıt Pr.

1.275 kg/m 26 mm Polyurethane Filled Mullion Profile

Jx=11,56 cm⁴ Jy=8,55 cm⁴

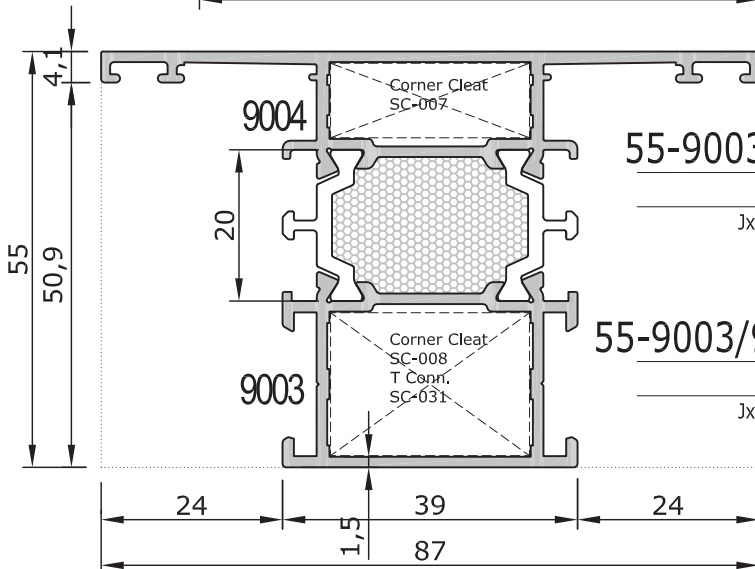

55-9003/9004 39 mm Orta Kayıt Pr.

1.465 kg/m 39 mm Mullion Profile

Jx=13,89 cm⁴ Jy=16,27 cm⁴

55-9003/9004-P 39 mm Poliüretan Dolgulu Orta Kayıt Pr.

1.490 kg/m 39 mm Polyurethane Filled Mullion Profile

Jx=13,89 cm⁴ Jy=16,27 cm⁴

Dikkat: Poliüretan doldurulmuş profiller talep üzerine yapılır.
Minimum sipariş miktarı her bir profil için 100 boydur.
Warning: Polyurethane infilling is made on request
Minimum order quantity: 100 bar

Uyarı: Profil ağırlıklarımız teorik olup; teslim anındaki tartımız geçerlidir.
Warning: the weights of profile is theoretical, weighting at the time of delivery are valid.

Full Scale Sections

Tam Ölçekli Profil Kesitleri

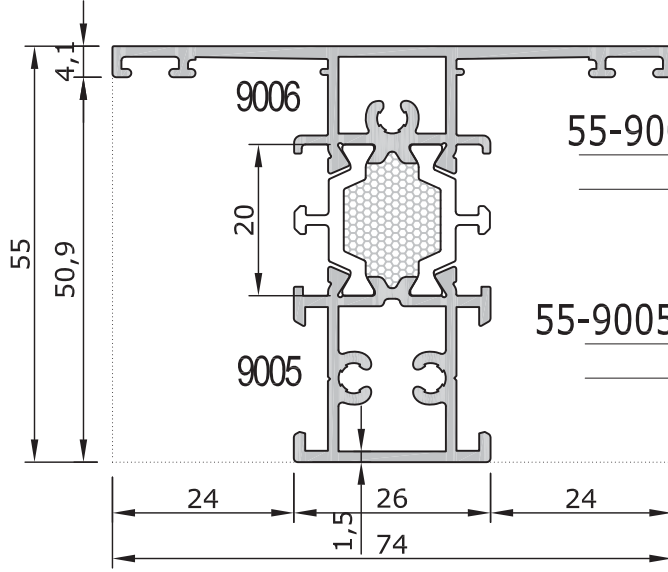
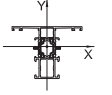

55-9005/9006	26 mm Orta Kayıt Pr.
1.375 kg/m	26 mm Mullion Profile
$J_x=12,66 \text{ cm}^4$	$J_y=8,60 \text{ cm}^4$

55-9005/9006-P	26 mm Poliüretan Dolgulu Orta Kayıt Pr.
1.385 kg/m	26 mm Polyurethane Filled Mullion Profile
$J_x=12,66 \text{ cm}^4$	$J_y=8,60 \text{ cm}^4$

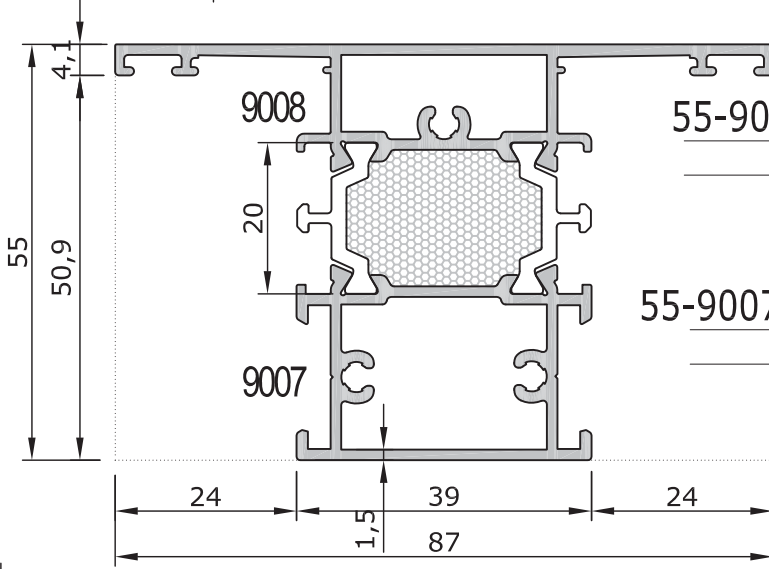

55-9007/9008	39 mm Orta Kayıt Pr.
1.565 kg/m	39 mm Mullion Profile
$J_x=14,90 \text{ cm}^4$	$J_y=16,53 \text{ cm}^4$

55-9007/9008-P	39 mm Poliüretan Dolgulu Orta Kayıt Pr.
1.590 kg/m	39 mm Polyurethane Filled Mullion Profile
$J_x=14,90 \text{ cm}^4$	$J_y=16,53 \text{ cm}^4$

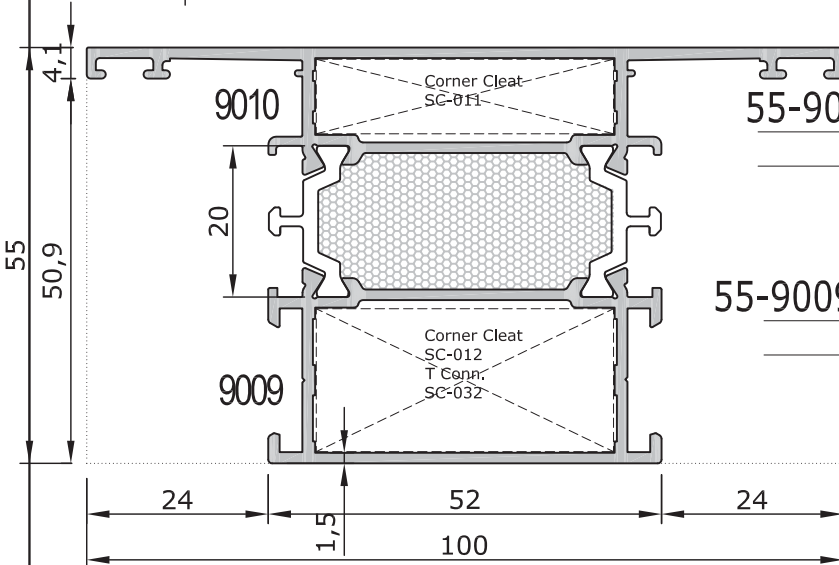

55-9009/9010	52mm Orta Kayıt Pr.
1.650 kg/m	52 mm Mullion Profile
$J_x=16,19 \text{ cm}^4$	$J_y=27,96 \text{ cm}^4$

55-9009/9010-P	52mm Poliüretan Dolgulu Orta Kayıt Pr.
1.690 kg/m	52 mm Polyurethane Filled Mullion Profile
$J_x=16,19 \text{ cm}^4$	$J_y=27,96 \text{ cm}^4$

Dikkat: Poliüretan doldurulmuş profiller talep üzerine yapılır.
Minimum sipariş miktarı her bir profil için 100 boydudur.
Warning: Polyurethane infilling is made on request
Minimum order quantity: 100 bar

Uyarı: Profil ağırlıklarımız teorik olup; teslim anındaki tartımız geçerlidir.
Warning: the weights of profile is theoretical, weighting at the time of delivery are valid.

Full Scale Sections

Tam Ölçekli Profil Kesitleri

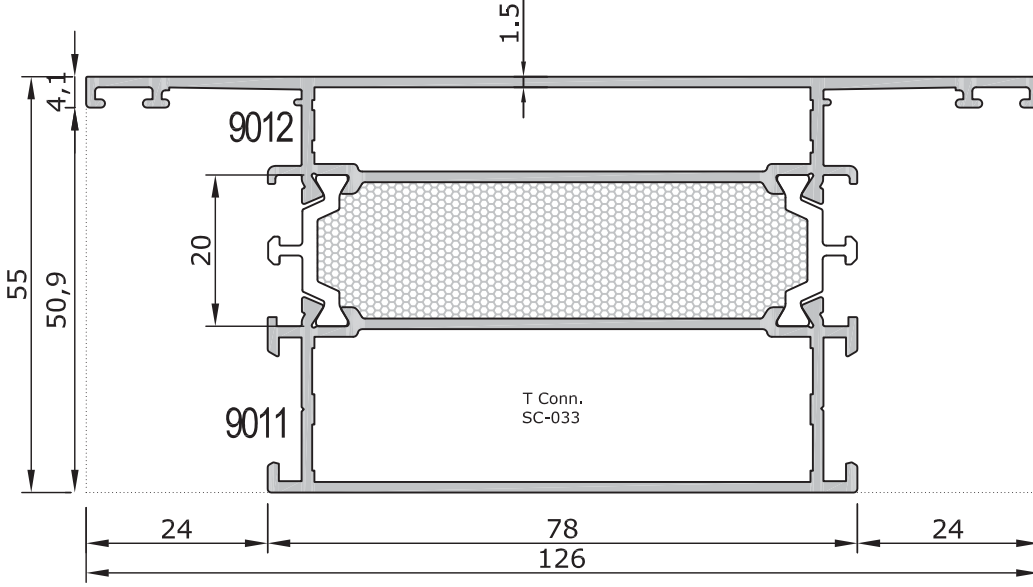
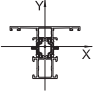

55-9011/9012	78 mm Orta Kayıt Profili
2,060 kg/m	78 mm Mullion Profile
$J_x=20,76 \text{ cm}^4$	$J_y=65,69 \text{ cm}^4$

55-9011/9012-P	78 mm Poliüretan Dolgulu Orta Kayıt Profili
2,130 kg/m	78 mm Polyurethane Filled Mullion Profile
$J_x=20,76 \text{ cm}^4$	$J_y=65,69 \text{ cm}^4$

Dikkat: Poliüretan doldurulmuş profiller talep üzerine yapılır.
Minimum sipariş miktarı her bir profil için 100 boydur.
Warning: Polyurethane infilling is made on request
Minimum order quantity: 100 bar

Uyarı: Profil ağırlıklarımız teorik olup; teslim anındaki tartımız geçerlidir.
Warning: the weights of profile is theoretical, weighting at the time of delivery are valid.

Full Scale Sections

Tam Ölçekli Profil Kesitleri

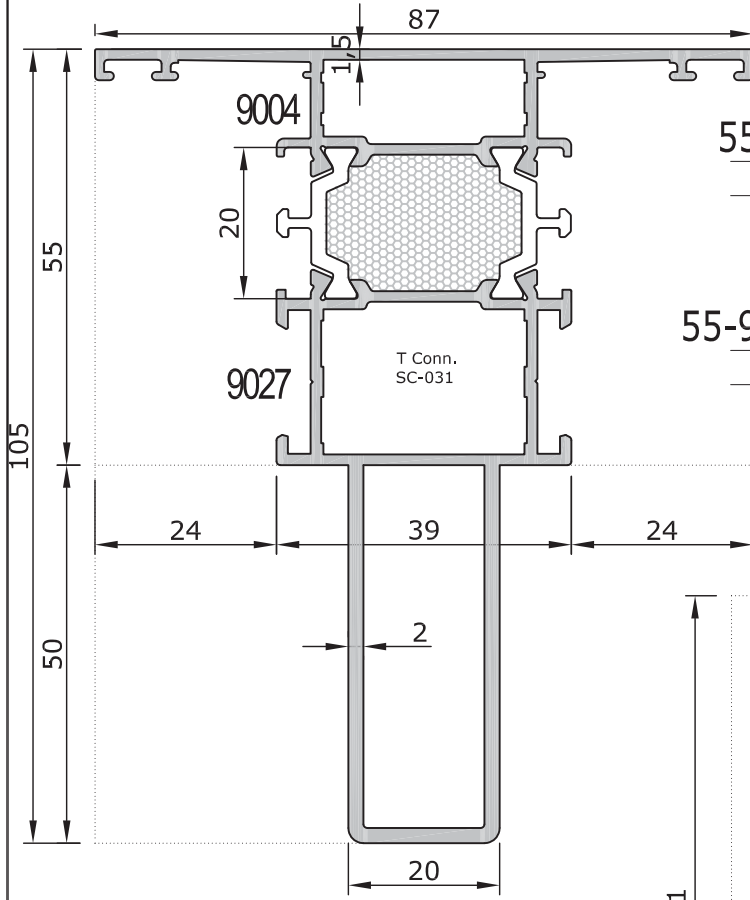
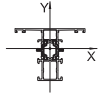

55-9027/9004	Takviyeli Orta Kayıt Pr.
2,090 kg/m	Reinforced Transom Pr.
$J_x=62,55 \text{ cm}^4$	$J_y=17,95 \text{ cm}^4$

55-9027/9004-P	Poliüretan Dolgulu Takviyeli Orta Kayıt Pr.
2,115 kg/m	Polyurethane Filled Reinforced Transom Pr.
$J_x=62,55 \text{ cm}^4$	$J_y=17,95 \text{ cm}^4$

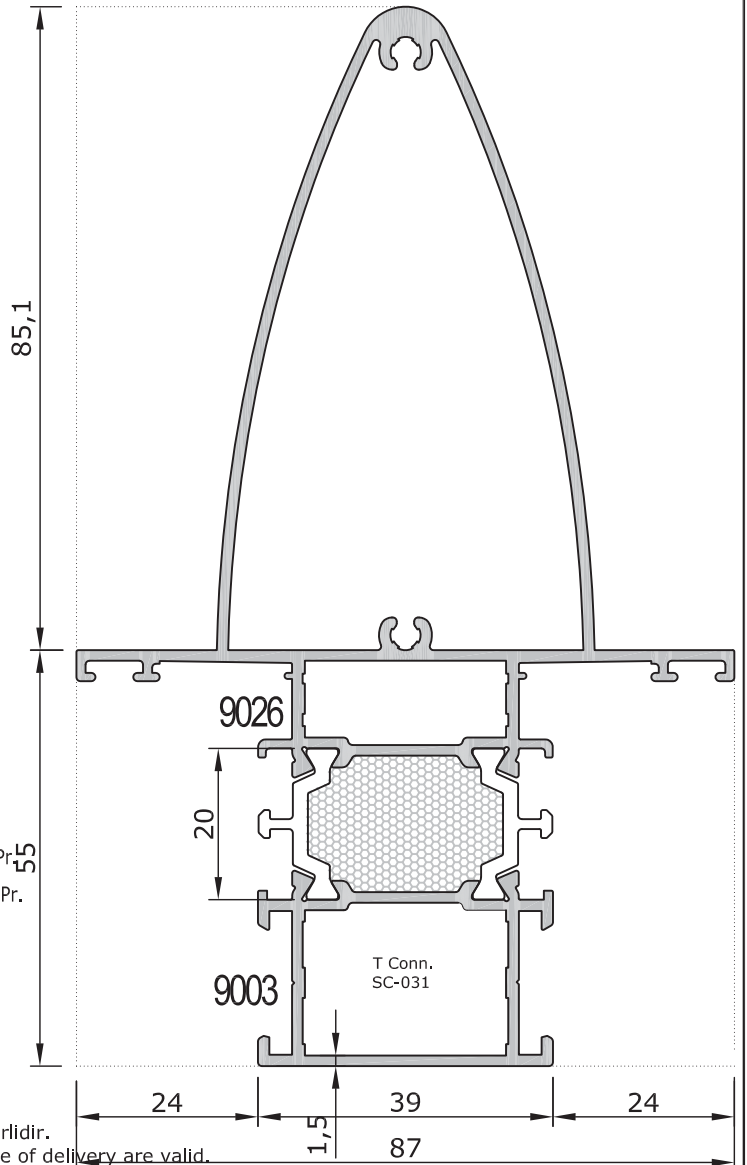

55-9003/9026	Takviyeli Orta Kayıt Pr.
2,325 kg/m	Reinforced Transom Pr.
$J_x=96,57 \text{ cm}^4$	$J_y=24,82 \text{ cm}^4$

55-9003/9026-P	Poliüretan Dolgulu Takviyeli Orta Kayıt Pr.
2,350 kg/m	Polyurethane Filled Reinforced Transom Pr.
$J_x=96,57 \text{ cm}^4$	$J_y=24,82 \text{ cm}^4$

Dikkat: Poliüretan doldurulmuş profiller talep üzerine yapılır.
Minimum sipariş miktarı her bir profil için 100 boydur.
Warning: Polyurethane infilling is made on request
Minimum order quantity: 100 bar

Uyarı: Profil ağırlıklarımız teorik olup; teslim anındaki tartımız geçerlidir.
Warning: the weights of profile is theoretical, weighting at the time of delivery are valid.

Full Scale Sections

Tam Ölçekli Profil Kesitleri

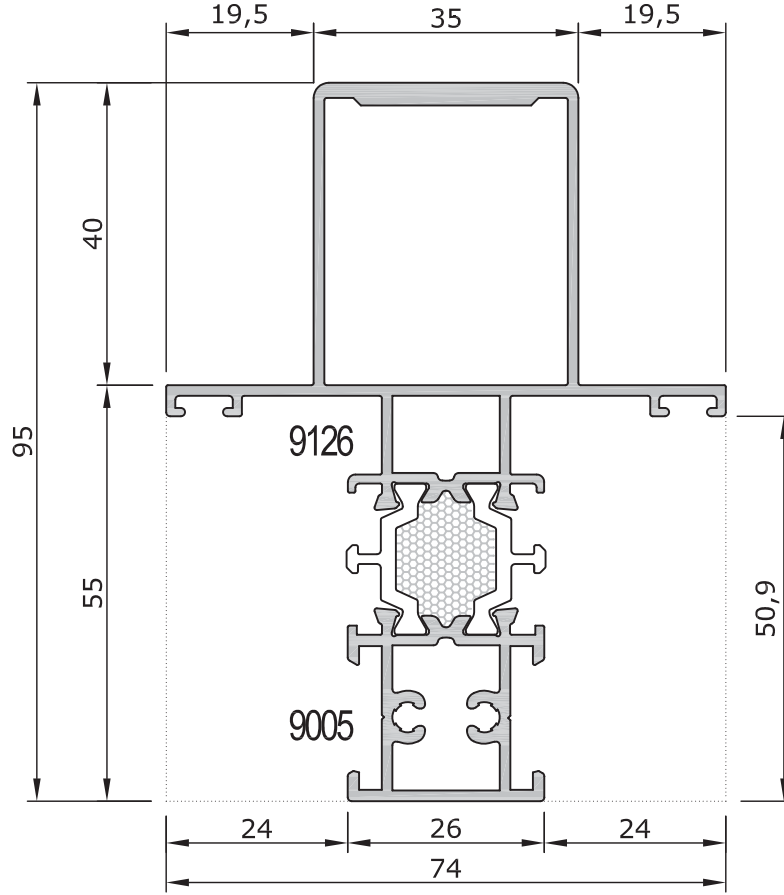
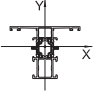

***55-9005/9126** Takviyeli Orta Kayıt Pr.
1,810 kg/m Reinforced Transom Pr.
 $J_x=41,12 \text{ cm}^4$ $J_y=12,36 \text{ cm}^4$

55-9005/9126-P Poliüretan Dolgulu Takviyeli Orta Kayıt Pr.
1,820 kg/m Polyurethane Filled Reinforced Transom Pr.
 $J_x=41,12 \text{ cm}^4$ $J_y=12,36 \text{ cm}^4$

Dikkat: Poliüretan doldurulmuş profiller talep üzerine yapılır.
Minimum sipariş miktarı her bir profil için 100 boydur.
Warning: Polyurethane infilling is made on request
Minimum order quantity: 100 bar

* Sipariş miktarı minimum 600 kg dır. / Minimum order quantity: 600 kg

Uyarı: Profil ağırlıklarımız teorik olup; teslim anındaki tartımız geçerlidir.

Warning: the weights of profile is theoretical, weighting at the time of delivery are valid.

Mullion Profile for Ssash Full Scale Sections

Kanat İçi Ortakayıt Profili Tam Ölçekli Profil Kesitleri

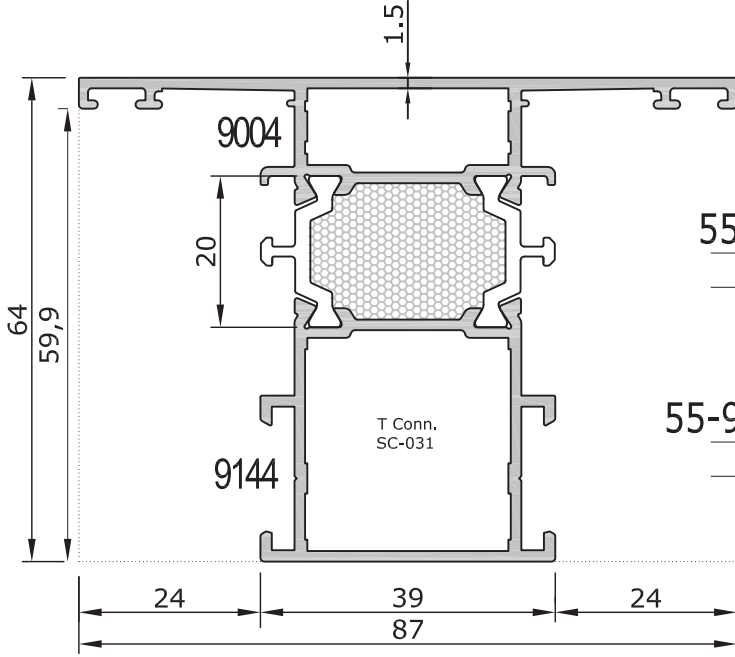
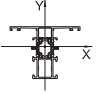

55-9144/9004 | 39 mm Kanat Orta Kayıt Profili

1,520 kg/m | 39 mm Mullion Profile for Sash
Jx=19,59 cm⁴ | Jy=16,70 cm⁴

55-9144/9004-P | 39 mm Poliüretan Dolgulu Kanat Orta Kayıt Profili

1,545 kg/m | 39 mm Polyurethane Filled Mullion Profile for Sash
Jx=19,59 cm⁴ | Jy=16,70 cm⁴

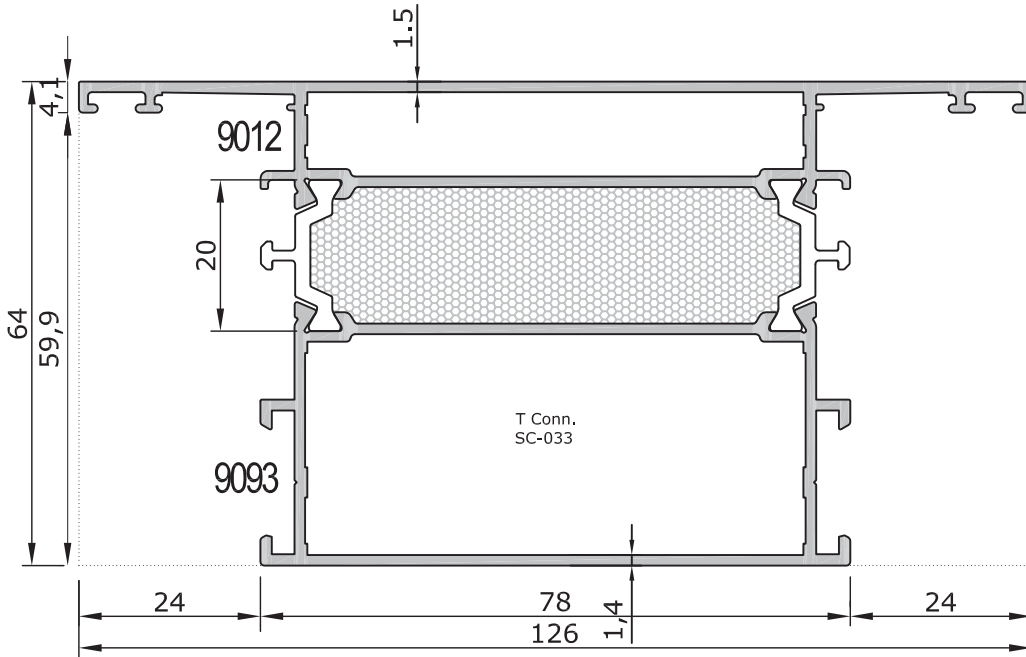

55-9093/9012 | Kanat Orta Kayıt ve Etek Pr.

2,120 kg/m | Mullion and Bottom Rail Pr. for Sash
Jx=28,82 cm⁴ | Jy=68,03 cm⁴

55-9093/9012-P | Poliüretan Dolgulu Kanat Orta Kayıt ve Etek Pr.

2,190 kg/m | Polyurethane Filled Mullion and Bottom Rail Pr. for Sash
Jx=28,82 cm⁴ | Jy=68,03 cm⁴

Dikkat: Poliüretan doldurulmuş profiller talep üzerine yapılır.
Minimum sipariş miktarı her bir profil için 100 boydur.
Warning: Polyurethane infilling is made on request
Minimum order quantity: 100 bar

55-9024/9025 ve 55-9024-B/9025-B ile Kullanılır.

Uyarı: Profil ağırlıklarımız teorik olup; teslim anındaki tartımız geçerlidir.

Warning: the weights of profile is theoretical, weighting at the time of delivery are valid.

Full Scale Sections

Tam Ölçekli Profil Kesitleri

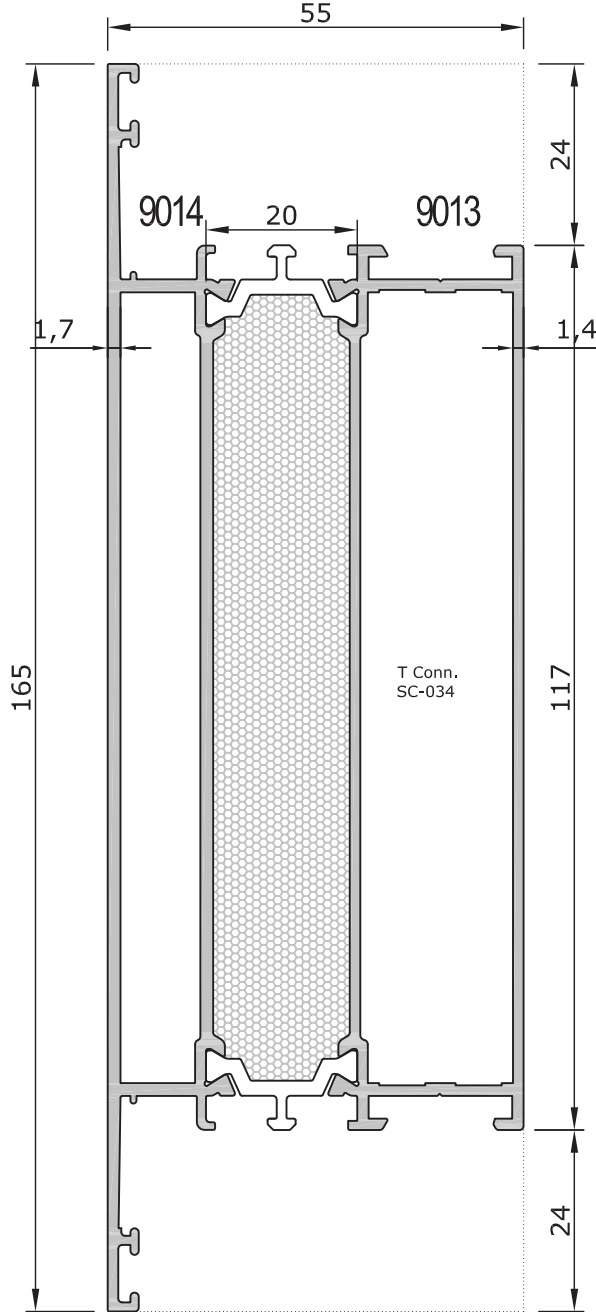
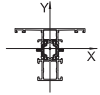

Dikkat: Poliüretan doldurulmuş profiller talep üzerine yapılır.
Minimum sipariş miktarı her bir profil için 100 boydur.
Warning: Polyurethane infilling is made on request
Minimum order quantity: 100 bar

55-9013/9014	Sabit Etek Profili
2,810 kg/m	Bottom Rail Profile
Jx=28,91 cm ⁴	Jy=172,89 cm ⁴

55-9013/9014-P	Poliüretan Dolgulu Sabit Etek Profili
2,925 kg/m	Polyurethane Filled Bottom Rail Profile
Jx=28,91 cm ⁴	Jy=172,89 cm ⁴

Uyarı: Profil ağırlıklarımız teorik olup; teslim anındaki tartımız geçerlidir.
Warning: the weights of profile is theoretical, weighting at the time of delivery are valid.

Full Scale Sections (2mm Thick Profiles) Tam Ölçekli Profil Kesitleri (2mm Kalın Profiller)

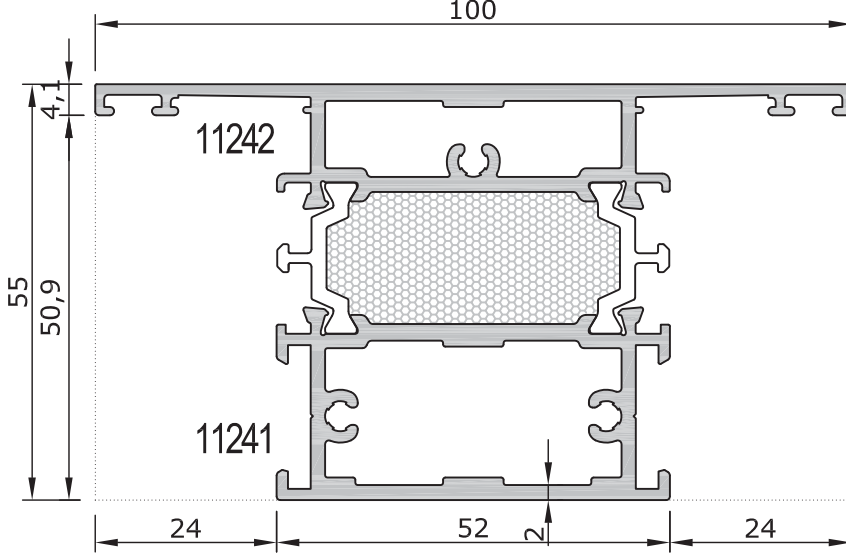
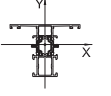

55-11241/11242	52mm Orta Kayıt Pr.
2,195 kg/m	52 mm Mullion Profile
Jx=22,29 cm ⁴	Jy=31,17 cm ⁴

55-11241/11242-P	52 mm Poliüretan Dolgulu Orta Kayıt Pr.
2,235 kg/m	52 mm Polyurethane Filled Mullion Pr.
Jx=22,29 cm ⁴	Jy=31,17 cm ⁴

Dikkat: Poliüretan doldurulmuş profiller talep üzerine yapılır.
Minimum sipariş miktarı her bir profil için 100 boydur.
Warning: Polyurethane infilling is made on request
Minimum order quantity: 100 bar

Uyarı: Profil ağırlıklarımız teorik olup; teslim anındaki tartımız geçerlidir.
Warning: the weights of profile is theoretical, weighting at the time of delivery are valid.

Full Scale Sections (2mm Thick Profiles)

Tam Ölçekli Profil Kesitleri (2mm Kalın Profiller)

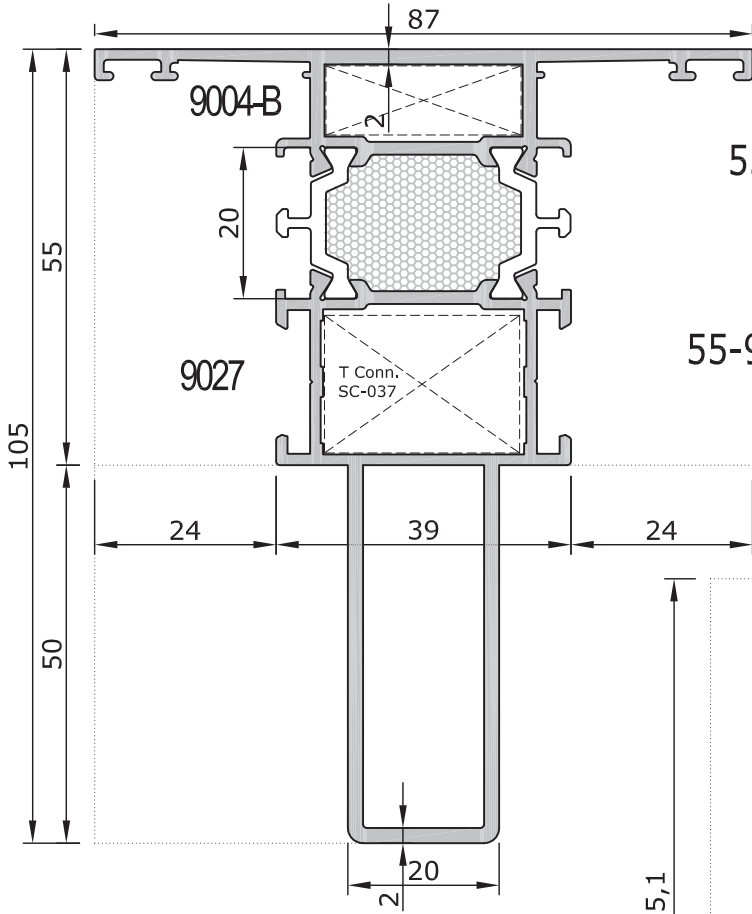
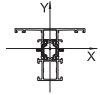

55-9027/9004-B Takviyeli Orta Kayıt Pr.

2,115 kg/m	Reinforced Transom Pr.
$J_x=65,19 \text{ cm}^4$	$J_y=18,15 \text{ cm}^4$

55-9027/9004-B-P Poliüretan Dolgulu Takviyeli Orta Kayıt Pr.

2,140 kg/m	Polyurethane Filled Reinforced Transom Pr.
$J_x=65,19 \text{ cm}^4$	$J_y=18,15 \text{ cm}^4$

Dikkat: Poliüretan doldurulmuş profiller talep üzerine yapılır.
Minimum sipariş miktarı her bir profil için 100 boydur.
Warning: Polyurethane infilling is made on request
Minimum order quantity: 100 bar

55-9003-B/9026 Takviyeli Orta Kayıt Pr.

2,425 kg/m	Reinforced Transom Pr.
$J_x=103,46 \text{ cm}^4$	$J_y=25,18 \text{ cm}^4$

55-9003-B/9026-P Poliüretan Dolgulu Takviyeli Orta Kayıt Pr.

2,450 kg/m	Polyurethane Filled Reinforced Transom Pr.
$J_x=103,46 \text{ cm}^4$	$J_y=25,18 \text{ cm}^4$

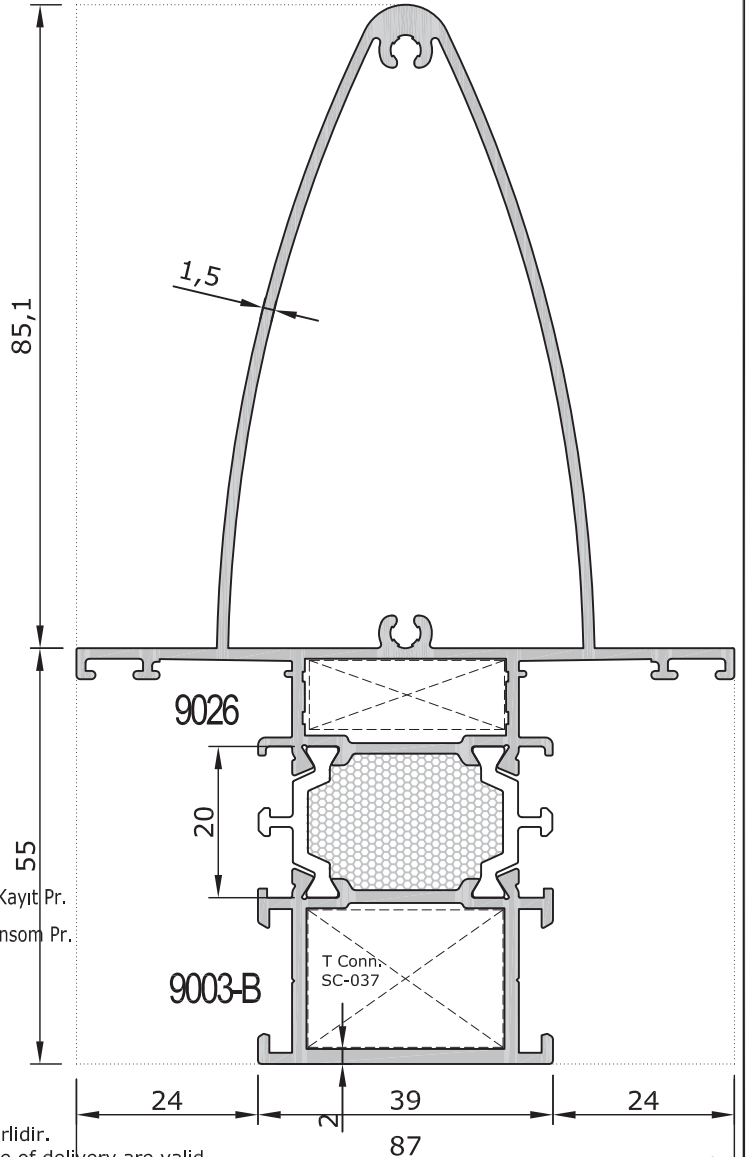

Uyarı: Profil ağırlıklarımız teorik olup; teslim anındaki tartımız geçerlidir.
Warning: the weights of profile is theoretical, weighting at the time of delivery are valid.

Full Scale Sections

Tam Ölçekli Profil Kesitleri

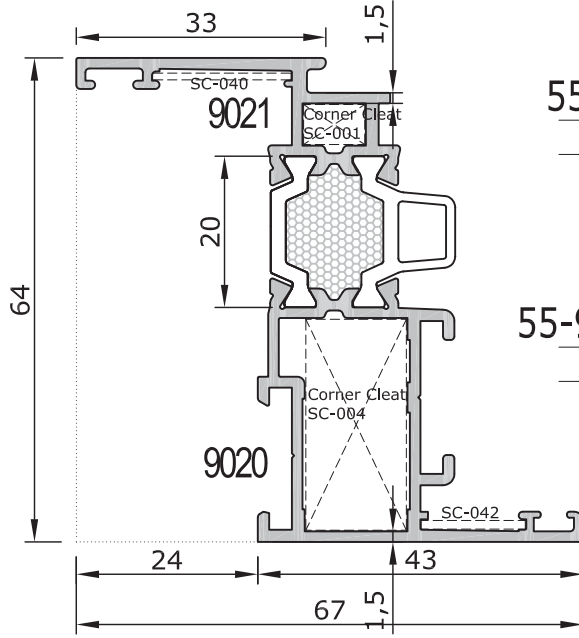
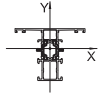

55-9020/9021	43 mm Kanat Profili
1,250 kg/m	43 mm Sash Profile
$J_x=15,69 \text{ cm}^4$	$J_y=6,69 \text{ cm}^4$

55-9020/9021-P	43 mm Poliüretan Dolgulu Kanat Profili
1,260 kg/m	43 mm Polyurethane Filled Sash Profile
$J_x=15,69 \text{ cm}^4$	$J_y=6,69 \text{ cm}^4$

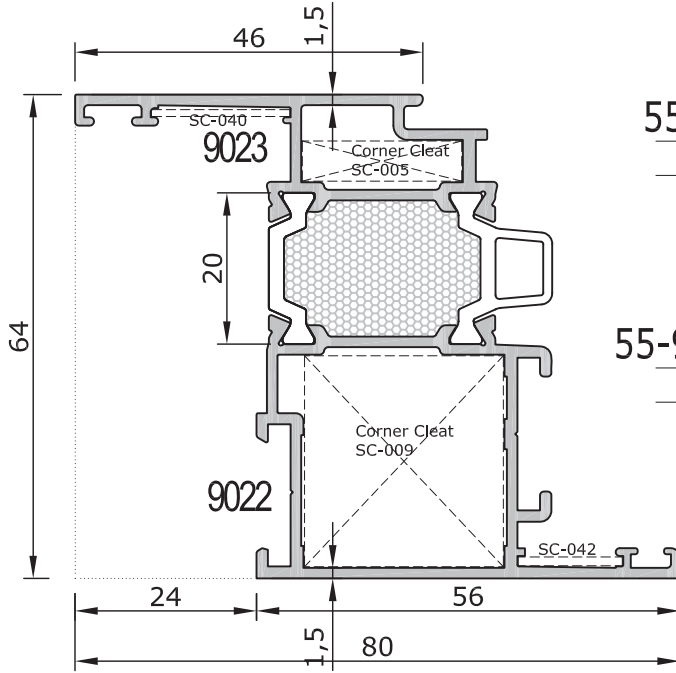

55-9022/9023	56 mm Kanat Profili
1,465 kg/m	56 mm Sash Profile
$J_x=19,02 \text{ cm}^4$	$J_y=13,57 \text{ cm}^4$

55-9022/9023-P	56 mm Poliüretan Dolgulu Kanat Profili
1,490 kg/m	56 mm Polyurethane Filled Sash Profile
$J_x=19,02 \text{ cm}^4$	$J_y=13,57 \text{ cm}^4$

Dikkat: Poliüretan doldurulmuş profiller talep üzerine yapılır.
Minimum sipariş miktarı her bir profil için 100 boydur.
Warning: Polyurethane infilling is made on request
Minimum order quantity: 100 bar

Uyarı: Profil ağırlıklarımız teorik olup; teslim anındaki tartımız geçerlidir.
Warning: the weights of profile is theoretical, weighting at the time of delivery are valid.

Full Scale Sections

Tam Ölçekli Profil Kesitleri

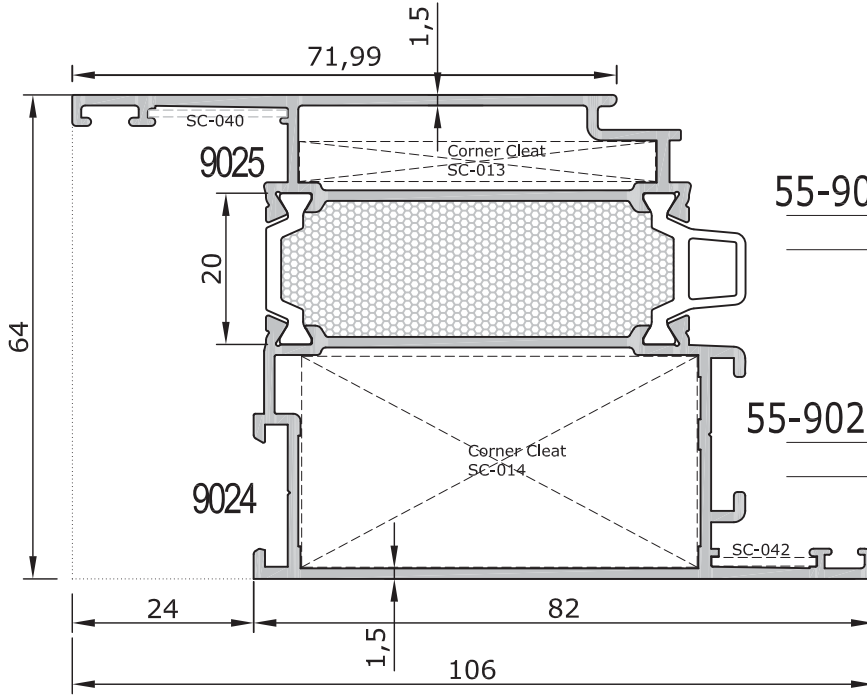
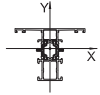

55-9024/9025	82 mm Kanat Profili
1,850 kg/m	82 mm Sash Profile
$J_x=25,24 \text{ cm}^4$	$J_y=39,70 \text{ cm}^4$

55-9024/9025-P	82 mm Poliüretan Dolgulu Kanat Pr.
1,905 kg/m	82 mm Polyurethane Filled Sash Pr.
$J_x=25,24 \text{ cm}^4$	$J_y=39,70 \text{ cm}^4$

Dikkat: Poliüretan doldurulmuş profiller talep üzerine yapılır.
Minimum sipariş miktarı her bir profil için 100 boydur.
Warning: Polyurethane infilling is made on request
Minimum order quantity: 100 bar

Uyarı: Profil ağırlıklarımız teorik olup; teslim anındaki tartımız geçerlidir.
Warning: the weights of profile is theoretical, weighting at the time of delivery are valid.

Full Scale Sections (2mm Thick Profiles)

Tam Ölçekli Profil Kesitleri (2mm Kalın Profiller)

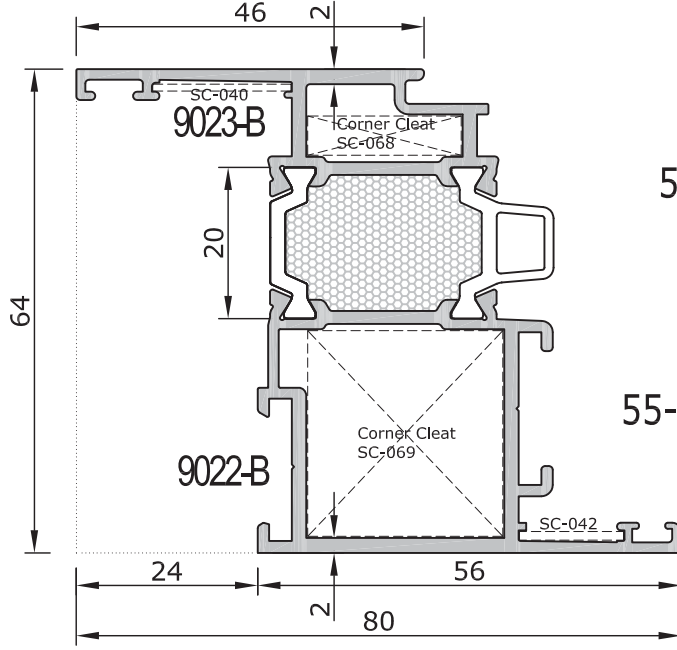
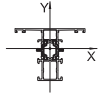

55-9022-B/9023-B | 56 mm Kanat Profili

1,620 kg/m | 56 mm Sash Profile

Jx=21,60 cm⁴ | Jy=14,16 cm⁴

55-9022-B/9023-B-P | 56 mm Poliüretan Dolgulu Kanat Pr.

1,645 kg/m | 56 mm Polyurethane Filled Sash Pr.

Jx=21,60 cm⁴ | Jy=14,16 cm⁴

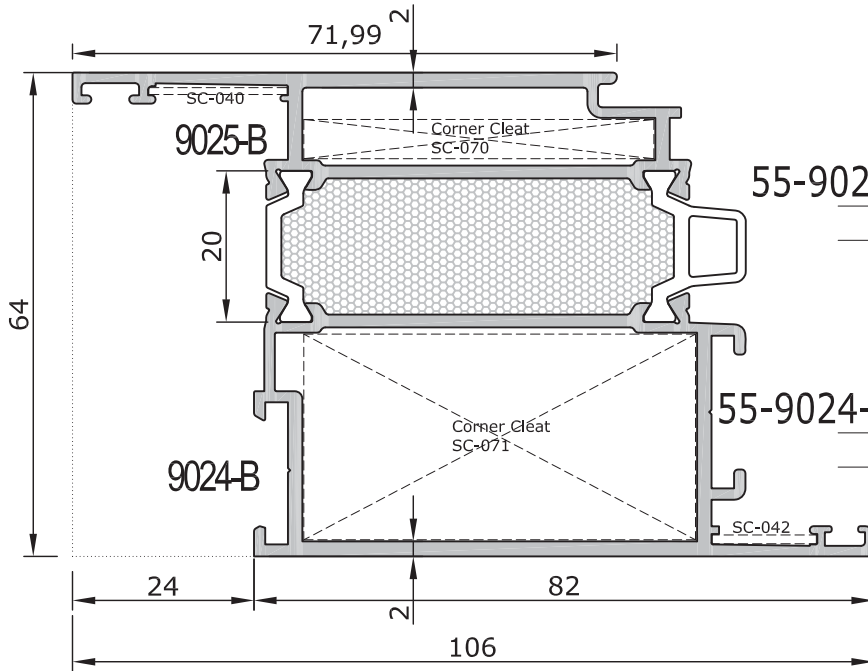

55-9024-B/9025-B | 82 mm Kanat Profili

2,135 kg/m | 82 mm Sash Profile

Jx=30,24 cm⁴ | Jy=42,86 cm⁴

55-9024-B/9025-B-P | 82 mm Poliüretan Dolgulu Kanat Pr.

2,190 kg/m | 82 mm Polyurethane Filled Sash Pr.

Jx=30,24 cm⁴ | Jy=42,86 cm⁴

Dikkat: Poliüretan doldurulmuş profiller talep üzerine yapılır.
Minimum sipariş miktarı her bir profil için 100 boydur.
Warning: Polyurethane infilling is made on request
Minimum order quantity: 100 bar

Uyarı: Profil ağırlıklarımız teorik olup; teslim anındaki tartımız geçerlidir.
Warning: the weights of profile is theoretical, weighting at the time of delivery are valid.

Full Scale Sections

Tam Ölçekli Profil Kesitleri

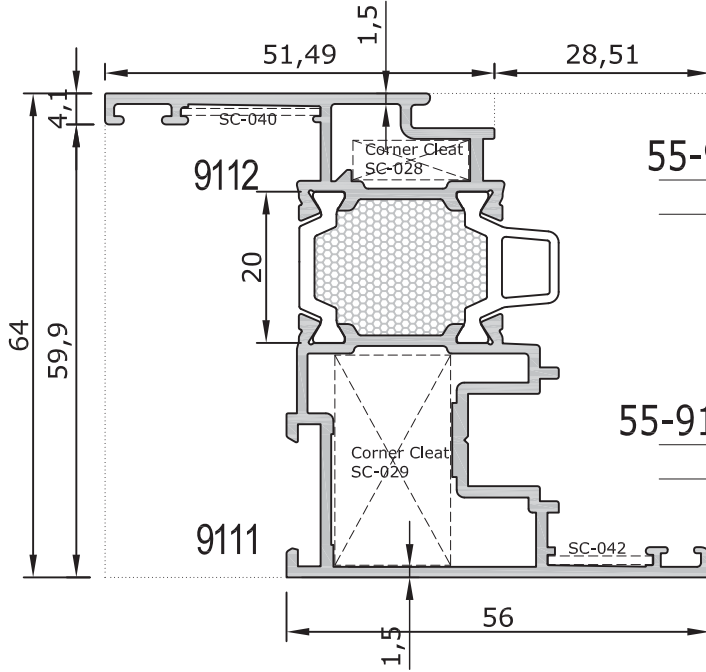
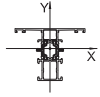

55-9111/9112	PVC Uyumlu Kanat
1,500 kg/m	Sash profile for PVC tilt and turn mechanism
$J_x=19,02 \text{ cm}^4$	$J_y=12,44 \text{ cm}^4$

55-9111/9112-P	Poliüretan Dolgulu PVC Uyumlu Kanat
1,525 kg/m	Sash profile for PVC tilt and turn mechanism
$J_x=19,02 \text{ cm}^4$	$J_y=12,44 \text{ cm}^4$

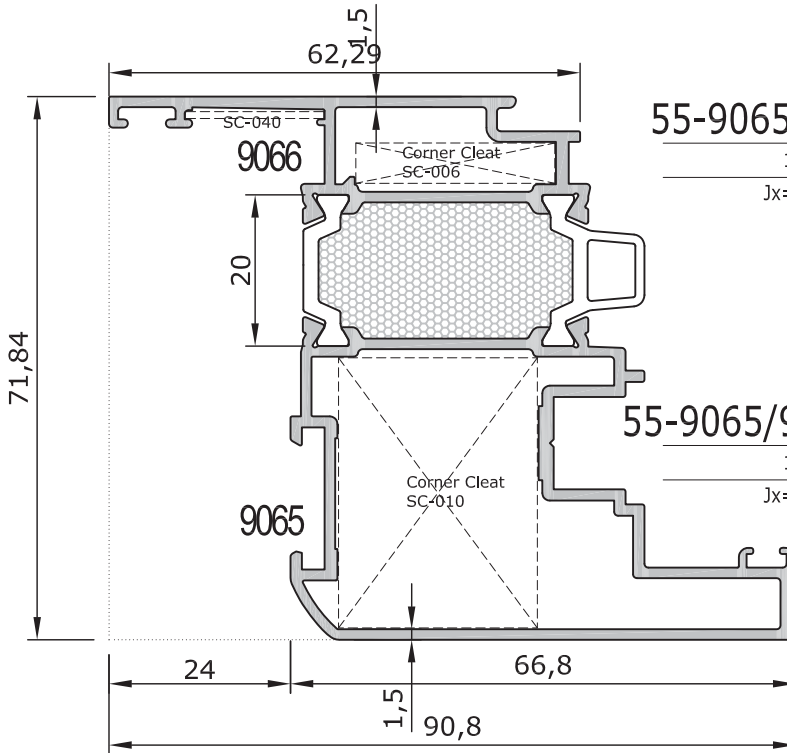

55-9065/9066	PVC Uyumlu Kanat
1,795 kg/m	Sash profile for PVC tilt and turn mechanism
$J_x=28,72 \text{ cm}^4$	$J_y=26,80 \text{ cm}^4$

55-9065/9066-P	Poliüretan Dolgulu PVC Uyumlu Kanat
1,835 kg/m	Polyurethane Filled Sash profile for PVC tilt and turn mechanism
$J_x=28,72 \text{ cm}^4$	$J_y=26,80 \text{ cm}^4$

Uyarı: Profil ağırlıklarımız teorik olup; teslim anındaki tartımız geçerlidir.
Warning: the weights of profile is theoretical, weighting at the time of delivery are valid.

Dikkat: Poliüretan doldurulmuş profiller talep üzerine yapılır.
Minimum sipariş miktarı her bir profil için 100 boydur.
Warning: Polyurethane infilling is made on request
Minimum order quantity: 100 bar

Full Scale Sections

Tam Ölçekli Profil Kesitleri

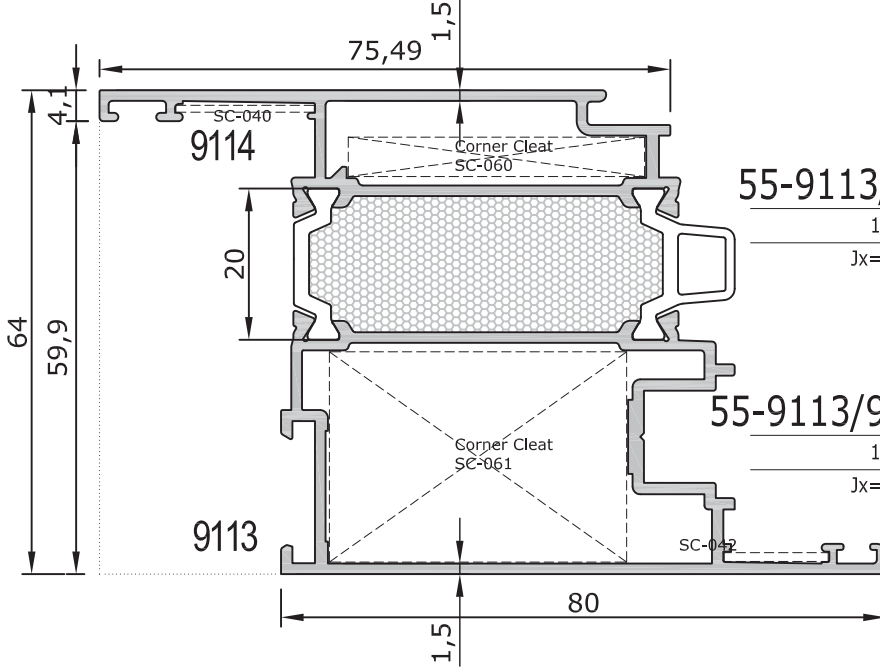
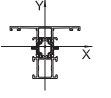

55-9113/9114	PVC Uyumlu Kanat
1,865 kg/m	Sash profile for PVC tilt and turn mechanism
Jx=24,82 cm ⁴	Jy=35,17 cm ⁴

55-9113/9114-P	Poliüretan Dolgulu PVC Uyumlu Kanat
1,915 kg/m	Polyurethane Filled Sash pr. for PVC tilt and turn mechanism
Jx=24,82 cm ⁴	Jy=35,17 cm ⁴

Dikkat: Poliüretan doldurulmuş profiller talep üzerine yapılır.
Minimum sipariş miktarı her bir profil için 100 boydur.
Warning: Polyurethane infilling is made on request
Minimum order quantity: 100 bar

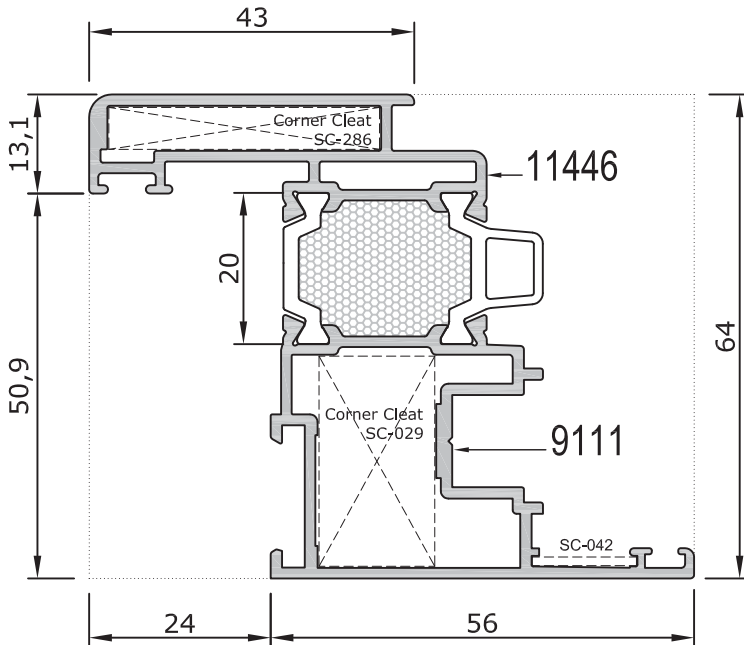

*55-9111/11446	56 mm Oval Kanat Profili
1,415 kg/m	56 mm Sash Profile
Jx=20,84 cm ⁴	Jy=17,34 cm ⁴

55-9111/11446-P	56 mm Poliüretan Dolgulu Oval Kanat Profili
1,440 kg/m	56 mm Polyurethane Filled Sash Profile
Jx=20,84 cm ⁴	Jy=17,34 cm ⁴

* Sipariş miktarı minimum 600 kg dir. / Minimum order quantity: 600 kg

Uyarı: Profil ağırlıklarımız teorik olup; teslim anındaki tartımız geçerlidir.

Warning: the weights of profile is theoretical, weighting at the time of delivery are valid.

Full Scale Sections

Tam Ölçekli Profil Kesitleri

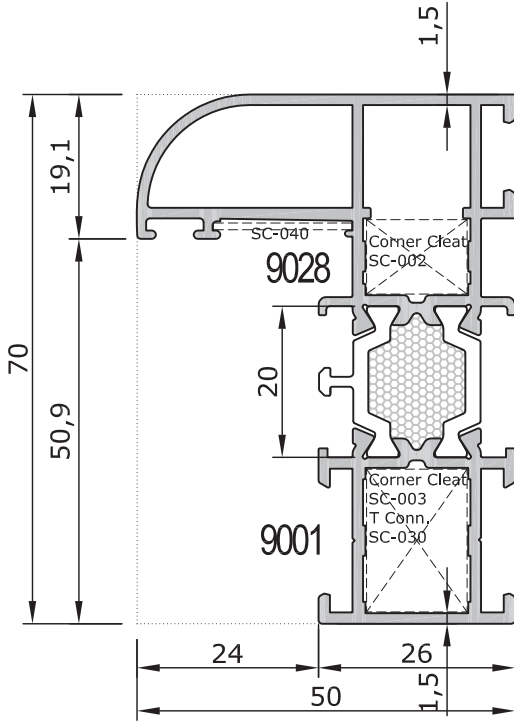
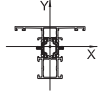

55-9001/9028 | 26 mm Oval Kasa Pr.

1.420 kg/m | 26 mm Frame Profile
 $J_x=18,06 \text{ cm}^4$ | $J_y=8,07 \text{ cm}^4$

55-9001/9028-P | 26 mm Poliüretan Dolgulu Oval Kasa Pr.

1.430 kg/m | 26 mm Polyurethane Filled Frame Profile
 $J_x=18,06 \text{ cm}^4$ | $J_y=8,07 \text{ cm}^4$

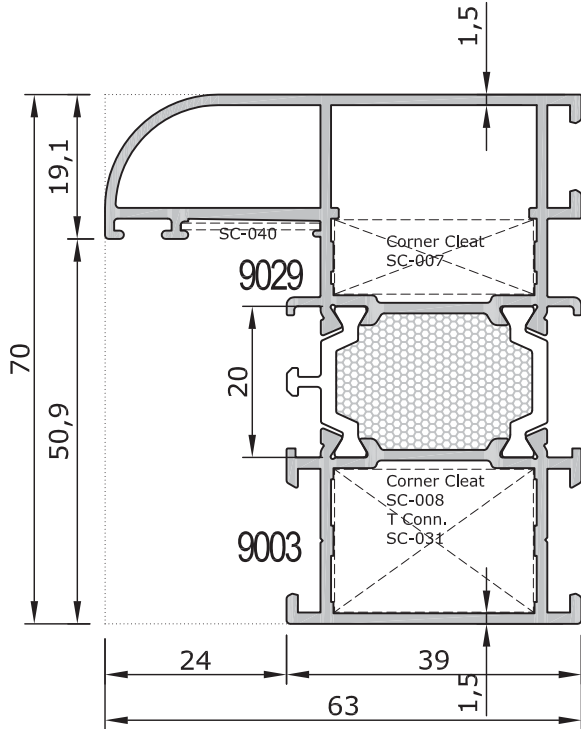

55-9003/9029 | 39 mm Oval Kasa Pr.

1.615 kg/m | 39 mm Frame Profile
 $J_x=21,70 \text{ cm}^4$ | $J_y=16,38 \text{ cm}^4$

55-9003/9029-P | 39 mm Poliüretan Dolgulu Oval Kasa Pr.

1.640 kg/m | 39 mm Polyurethane Filled Frame Profile
 $J_x=21,70 \text{ cm}^4$ | $J_y=16,38 \text{ cm}^4$

Uyarı: Profil ağırlıklarımız teorik olup; teslim anındaki tartımız geçerlidir.
 Warning: the weights of profile is theoretical, weighting at the time of delivery are valid.

Dikkat: Poliüretan doldurulmuş profiller talep üzerine yapılır.
 Minimum sipariş miktarı her bir profil için 100 boydur.
 Warning: Polyurethane infilling is made on request
 Minimum order quantity: 100 bar

Full Scale Sections

Tam Ölçekli Profil Kesitleri

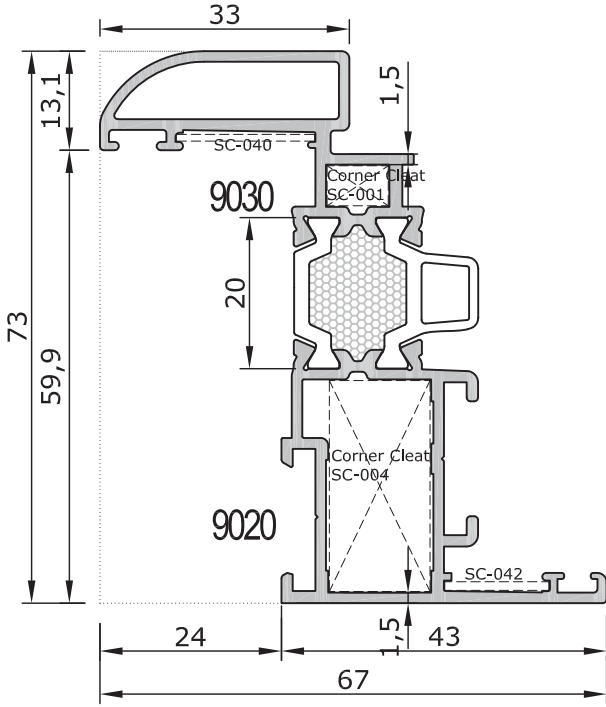
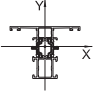

*55-9020/9030	43 mm Oval Kanat Profili
1,415 kg/m	43 mm Sash Profile
Jx=21,64 cm ⁴	Jy=8,76 cm ⁴

55-9020/9030-P	43 mm Poliüretan Dolgulu Oval Kanat Profili
1,425 kg/m	43 mm Polyurethane Filled Sash Profile
Jx=21,64 cm ⁴	Jy=8,76 cm ⁴

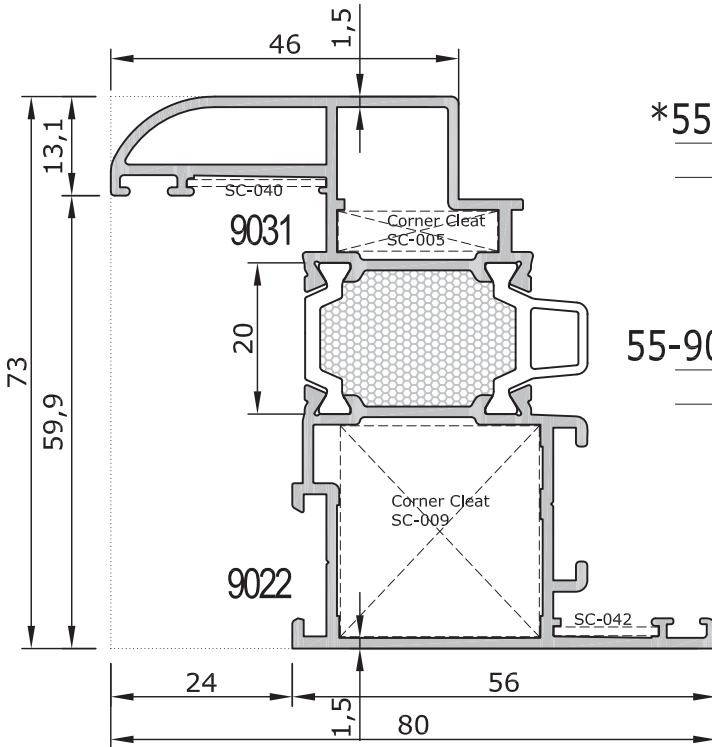

*55-9022/9031	56 mm Oval Kanat Profili
1,645 kg/m	56mm Sash Profile
Jx=26,10 cm ⁴	Jy=17,06 cm ⁴

55-9022/9031-P	56 mm Poliüretan Dolgulu Oval Kanat Profili
1,670 kg/m	56mm Polyurethane Filled Sash Profile
Jx=26,10 cm ⁴	Jy=17,06 cm ⁴

* Sipariş miktarı minimum 600 kg dir. / Minimum orde quantity: 600 kg
 Uyarı: Profil ağırlıklarımız teorik olup; teslim anındaki tartımız geçerlidir.
 Warning: the weights of profile is theoretical, weighting at the time of delivery are valid.

Dikkat: Poliüretan doldurulmuş profiller talep üzerine yapılır.
 Minimum sipariş miktarı her bir profil için 100 boydur.
 Warning: Polyurethane infilling is made on request
 Minimum order quantity: 100 bar

Full Scale Sections

Tam Ölçekli Profil Kesitleri

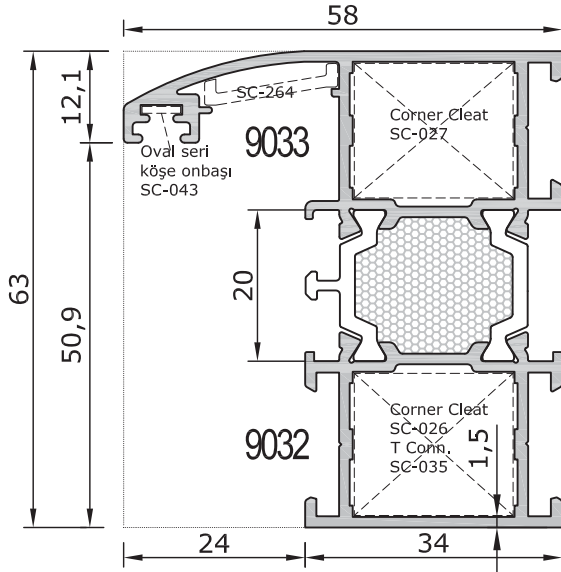
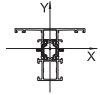

55-9032/9033	43 mm Oval Kasa Pr.
1.380 kg/m	43 mm Frame Profile
Jx=15,59 cm ⁴	Jy=10,41 cm ⁴

55-9032/9033-P	43 mm Poliüretan Dolgulu Oval Kasa Pr.
1.400 kg/m	43 mm Polyurethane Filled Frame Profile
Jx=15,59 cm ⁴	Jy=10,41 cm ⁴

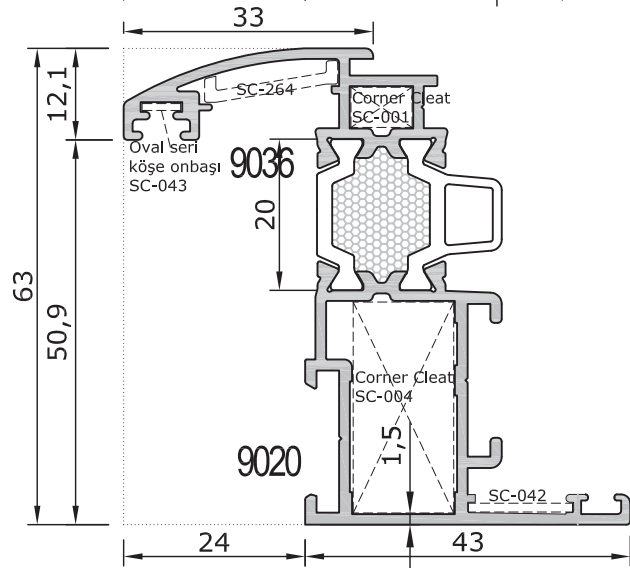

55-9020/9036	43 mm Oval Kanat Pr.
1.280 kg/m	43 mm Sash Pr.
Jx=15,12 cm ⁴	Jy=8,13 cm ⁴

55-9020/9036-P	43 mm Poliüretan Dolgulu Oval Kanat Pr.
1.290 kg/m	43 mm Polyurethane Filled Sash Pr.
Jx=15,12 cm ⁴	Jy=8,13 cm ⁴

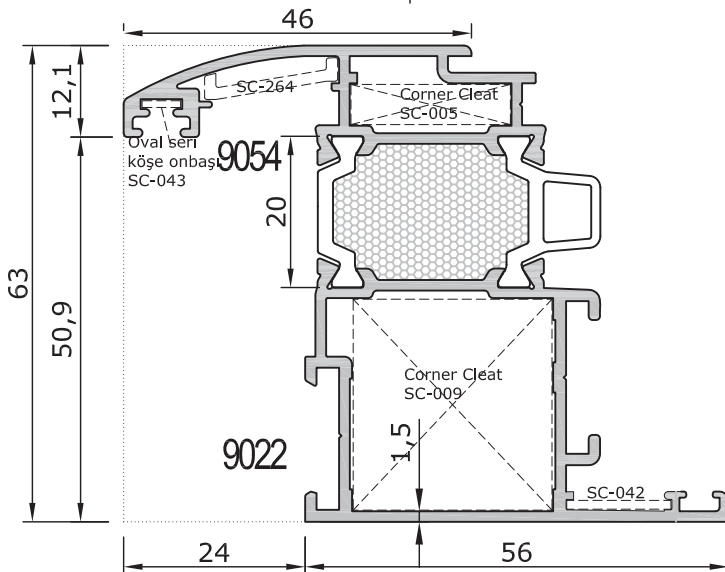

55-9022/9054	56 mm Oval Kanat Pr.
1.500 kg/m	56 mm Sash Pr.
Jx=18,49 cm ⁴	Jy=15,71 cm ⁴

55-9022/9054-P	56 mm Poliüretan Dolgulu Oval Kanat Pr.
1.525 kg/m	56 mm Polyurethane Filled Sash Pr.
Jx=18,49 cm ⁴	Jy=15,71 cm ⁴

Dikkat: Poliüretan doldurulmuş profiller talep üzerine yapılır.
Minimum sipariş miktarı her bir profil için 100 boydur.
Warning: Polyurethane infilling is made on request
Minimum order quantity: 100 bar

Uyarı: Profil ağırlıklarımız teorik olup; teslim anındaki tartımız geçerlidir.
Warning: the weights of profile is theoretical, weighting at the time of delivery are valid.

Full Scale Sections

Tam Ölçekli Profil Kesitleri

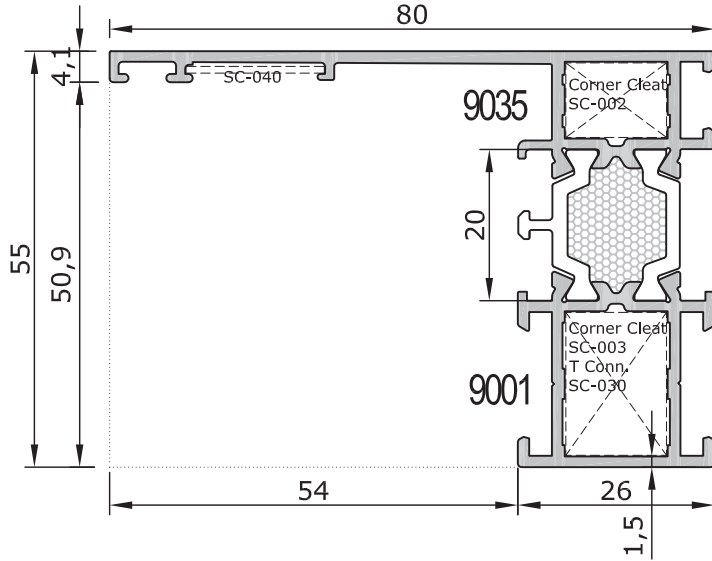
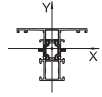

55-9001/9035	Gizli Kasa Profili
1.270 kg/m	Hidden Frame Profile
$J_x=11,67 \text{ cm}^4$	$J_y=16,80 \text{ cm}^4$

55-9001/9035-P	Poliüretan Dolgulu Gizli Kasa Profili
1.280 kg/m	Polyurethane Filled Hidden Frame Profile
$J_x=11,67 \text{ cm}^4$	$J_y=16,80 \text{ cm}^4$

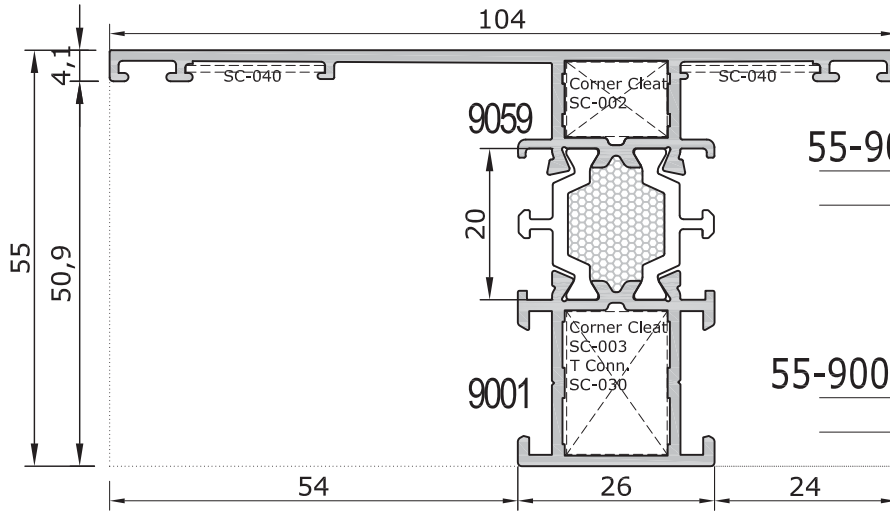

55-9001/9059	Gizli Kasa Profili
1.390 kg/m	Hidden Frame Profile
$J_x=12,86 \text{ cm}^4$	$J_y=22,10 \text{ cm}^4$

55-9001/9059-P	Poliüretan Dolgulu Gizli Kasa Profili
1.400 kg/m	Polyurethane Filled Hidden Frame Profile
$J_x=12,86 \text{ cm}^4$	$J_y=22,10 \text{ cm}^4$

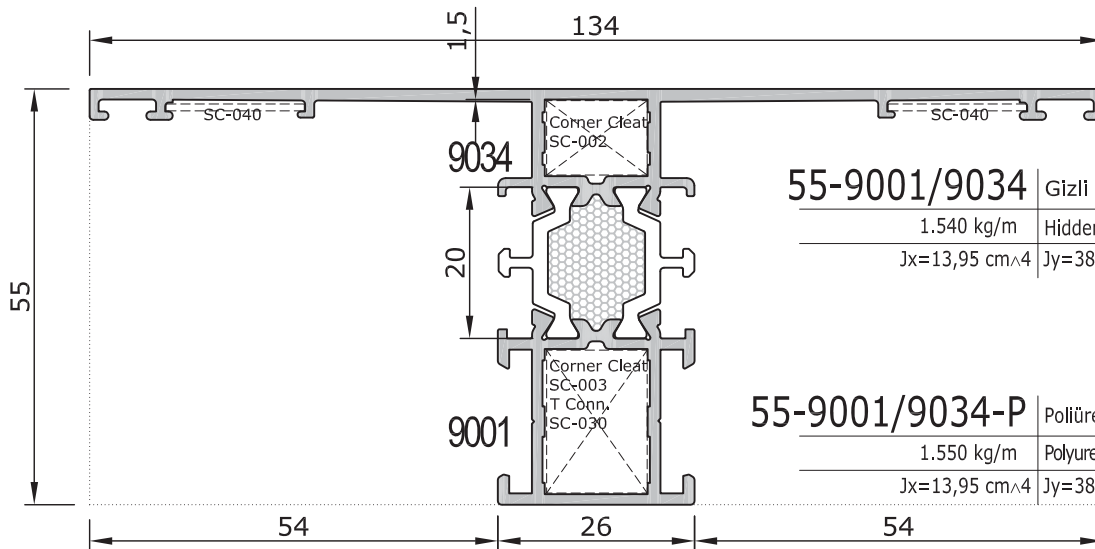

55-9001/9034	Gizli Orta Kayıt Pr.
1.540 kg/m	Hidden Mullion Profile
$J_x=13,95 \text{ cm}^4$	$J_y=38,85 \text{ cm}^4$

55-9001/9034-P	Poliüretan Dolgulu Gizli Orta Kayıt Pr.
1.550 kg/m	Polyurethane Filled Hidden Mullion Profile
$J_x=13,95 \text{ cm}^4$	$J_y=38,85 \text{ cm}^4$

Uyarı: Profil ağırlıklarımız teorik olup; teslim anındaki tartımız geçerlidir.
Warning: the weights of profile is theoretical, weighting at the time of delivery are valid.

Dikkat: Poliüretan doldurulmuş profiller talep üzerine yapılır.
Minimum sipariş miktarı her bir profil için 100 boydur.
Warning: Polyurethane infilling is made on request
Minimum order quantity: 100 bar

Full Scale Sections

Tam Ölçekli Profil Kesitleri

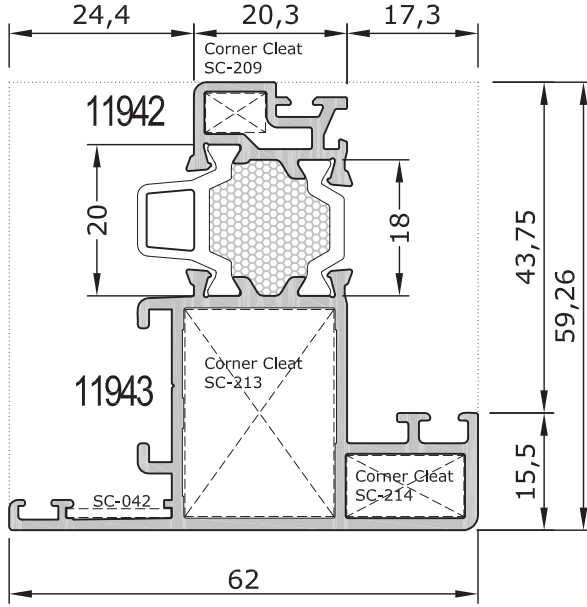
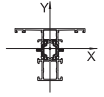

55-11942/11943	Gizli Kanat Profili
1.325 kg/m	Hidden Sash Profile
$Jx=13,04 \text{ cm}^4$	$Jy=8,86 \text{ cm}^4$

55-11942/11943-P	Poliüretan Dolgulu Gizli Kanat Profili
1.340 kg/m	Polyurethane Filled Hidden Sash Profile
$Jx=13,04 \text{ cm}^4$	$Jy=8,86 \text{ cm}^4$

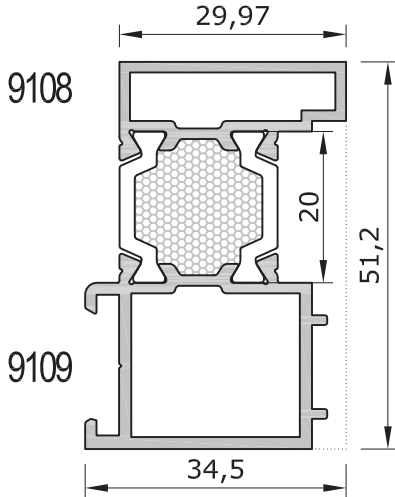

55-9108/9109	Gizli Kanat Çıta Adaptörü
1,000 kg/m	Hidden Sash for Bead Adapter
$Jx=7,55 \text{ cm}^4$	$Jy=3,24 \text{ cm}^4$

55-9108/9109-P	Poliüretan Dolgulu Gizli Kanat Çıta Adaptörü
1,015 kg/m	Hidden Sash for Bead Adapter
$Jx=7,55 \text{ cm}^4$	$Jy=3,24 \text{ cm}^4$

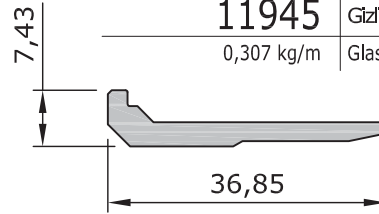

11945	Gizli Kanat Cam Taşıyıcı
0,307 kg/m	Glass Support for Hidden Sash

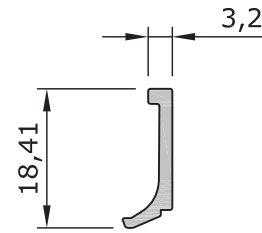

11944	Gizli Kanat Cam Çıtası
0,109 kg/m	Hidden Sash for Glazing Bead

Uyarı: Profil ağırlıklarımız teorik olup; teslim anındaki tartımız geçerlidir.
Warning: the weights of profile is theoretical, weighting at the time of delivery are valid.

Dikkat: Poliüretan doldurulmuş profiller talep üzerine yapılır.
Minimum sipariş miktarı her bir profil için 100 boydur.
Warning: Polyurethane infilling is made on request
Minimum order quantity: 100 bar

Full Scale Sections

Tam Ölçekli Profil Kesitleri

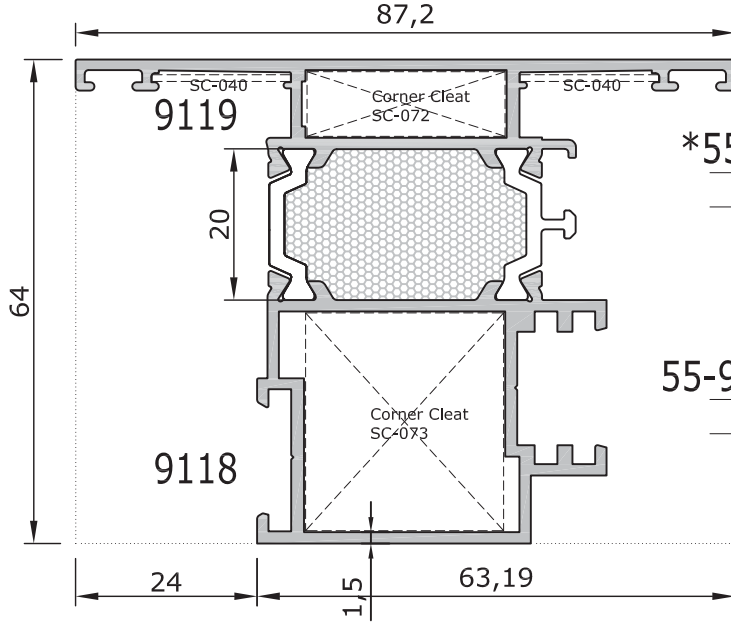

*55-9118/9119 Pivot İçin Kanat Profili

1,695 kg/m	Sash Profile for Pivot
Jx=21,24 cm ⁴	Jy=19,78 cm ⁴

55-9118/9119-P Poliüretan Dolgulu Pivot İçin Kanat Profili

1,730 kg/m	Polyurethane Filled Sash Profile for Pivot
Jx=21,24 cm ⁴	Jy=19,78 cm ⁴

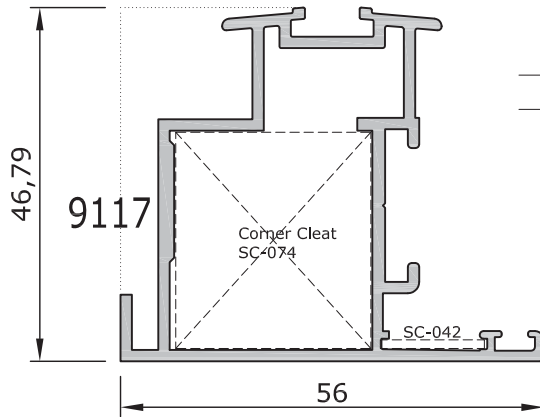

***9117 Pivot İçin Adaptör Profili

0,935 kg/m	Adapter Profile for Pivot
Jx=9,47 cm ⁴	Jy=7,34 cm ⁴

Dikkat: Poliüretan doldurulmuş profiller talep üzerine yapılır.
Minimum sipariş miktarı her bir profil için 100 boydur.
Warning: Polyurethane infilling is made on request
Minimum order quantity: 100 bar

* Sipariş miktarı minimum 600 kg dır. / Minimum orde quantity: 600 kg

*** Sipariş miktarı minimum 300 kg dır. / Minimum orde quantity: 300 kg

Uyarı: Profil ağırlıklarımız teorik olup; teslim anındaki tartımız geçerlidir.

Warning: the weights of profile is theoretical, weighting at the time of delivery are valid.

Full Scale Sections (1,8mm Thick Profiles) Tam Ölçekli Profil Kesitleri (1,8mm Kalın Profiller)

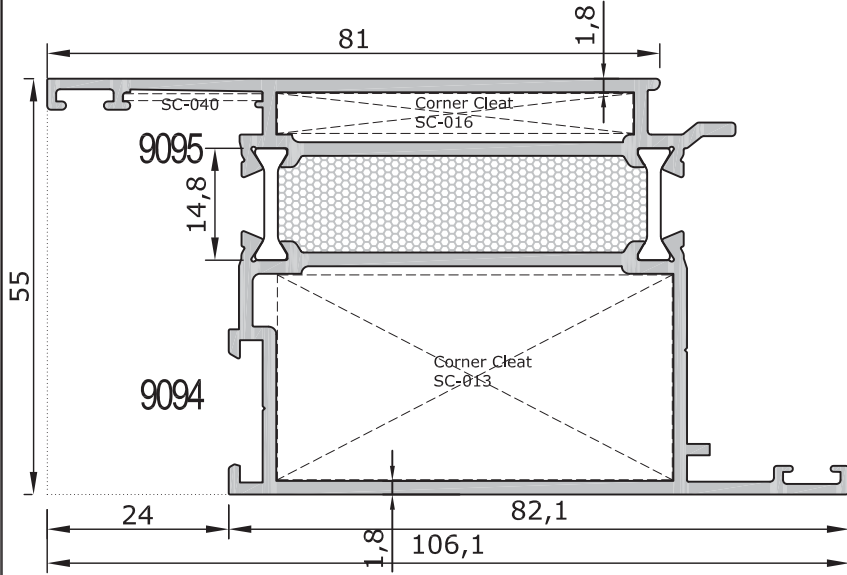
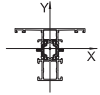

Dikkat: Poliüretan doldurulmuş profiller talep üzerine yapılır.
Minimum sipariş miktarı her bir profil için 100 boydudur.
Warning: Polyurethane infilling is made on request
Minimum order quantity: 100 bar

55-9094/9095 | İçe Ağır Hemyüz Kapı Kanat Profili
2,035 kg/m | Inside Opennig Door Profile
Jx=21,72 cm⁴ | Jy=43,63 cm⁴

55-9094/9095-P | Poliüretan Dalgulu İçe Ağır Hemyüz Kapı Kanat Profili
2,075 kg/m | Polyurethane Filled Inside Opennig Door Profile
Jx=21,72 cm⁴ | Jy=43,63 cm⁴

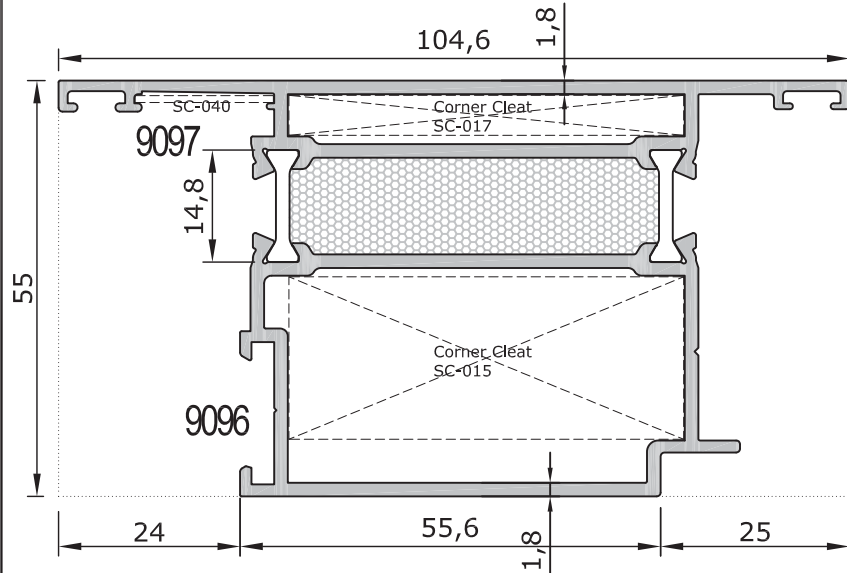

55-9096/9097 | Dışa Ağır Hemyüz Kapı Kanat Profili
2,030 kg/m | Outside Opennig Door Profile
Jx=20,16 cm⁴ | Jy=42,68 cm⁴

55-9096/9097-P | Poliüretan Dalgulu Dışa Ağır Hemyüz Kapı Kanat Profili
2,070 kg/m | Polyurethane Filled Outside Opennig Door Profile
Jx=20,16 cm⁴ | Jy=42,68 cm⁴

Uyarı: Profil ağırlıklarımız teorik olup; teslim anındaki tartımız geçerlidir.
Warning: the weights of profile is theoretical, weighting at the time of delivery are valid.

Full Scale Sections

Tam Ölçekli Profil Kesitleri

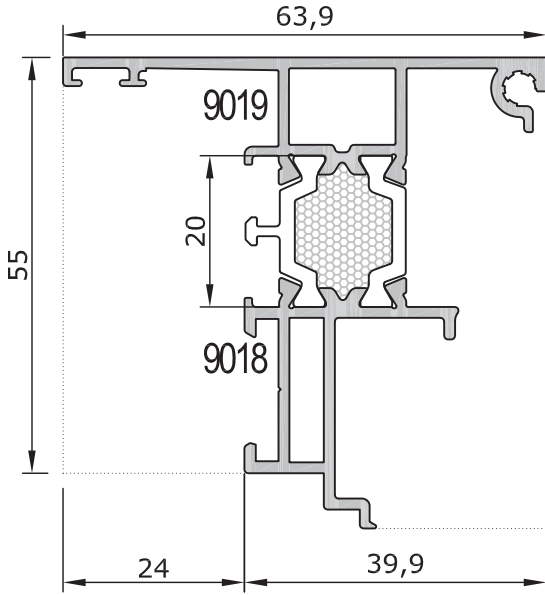
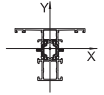

55-9018/9019 Çift Kanat Adaptörü

1.215 kg/m Double Sash Adapter
Jx=11,06 cm⁴ Jy=6,69 cm⁴

55-9018/9019-P Poliüretan Dolgulu Çift Kanat Adaptörü

1.225 kg/m Polyurethane Filled Double Sash Adapter

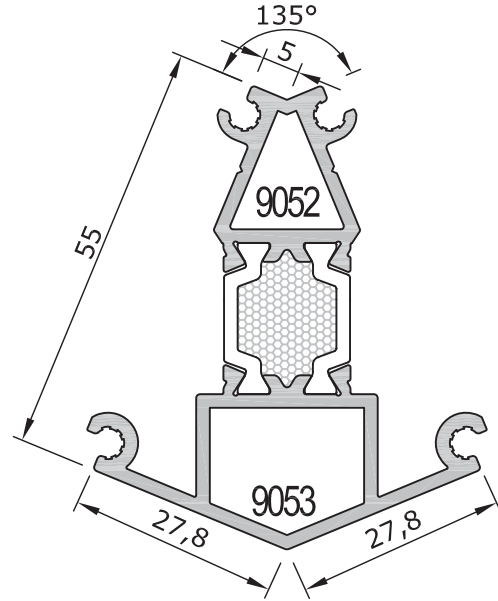

55-9052/9053 135° Dönüş Profili

1,305 kg/m 135° Corner Profile
Jx=11,18 cm⁴ Jy=5,66 cm⁴

55-9052/9053-P Poliüretan Dolgulu 135° Dönüş Profili

1,315 kg/m Polyurethane Filled 135° Corner Profile

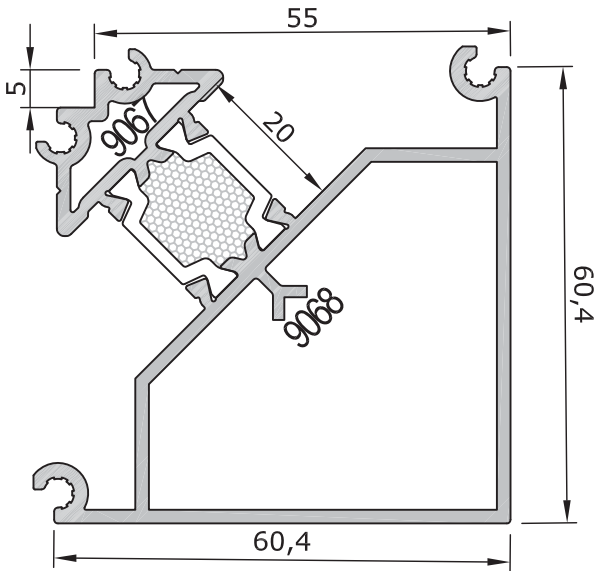

55-9067/9068 90° Dönüş Profili

1.790 kg/m 90° Corner Profile
Jx=19,98 cm⁴ Jy=26,65 cm⁴

55-9067/9068-P Poliüretan Dolgulu 90° Dönüş Profili

1.800 kg/m Polyurethane Filled 90° Corner Profile

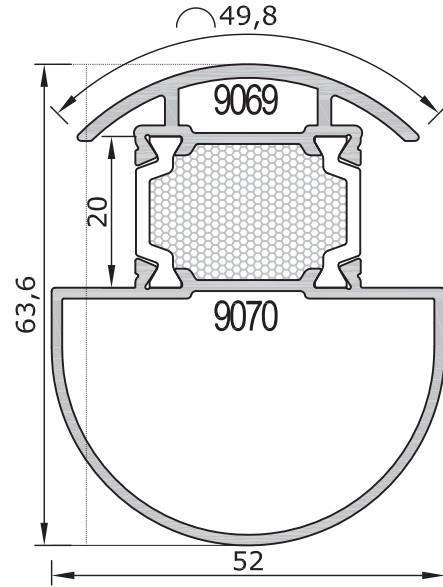

55-9069/9070 Açılı Dönüş Profili

1.250 kg/m Corner Profile
Jx=11,73 cm⁴ Jy=8,94 cm⁴

55-9069/9070-P Poliüretan Dolgulu Açılı Dönüş Profili

1.275 kg/m Polyurethane Filled Corner Profile

Dikkat: Poliüretan doldurulmuş profiller talep üzerine yapılır.
Minimum sipariş miktarı her bir profil için 100 boydudur.
Warning: Polyurethane infilling is made on request
Minimum order quantity: 100 bar

Uyarı: Profil ağırlıklarımız teorik olup; teslim anındaki tartımız geçerlidir.

Warning: the weights of profile is theoretical, weighting at the time of delivery are valid.

Full Scale Sections

Tam Ölçekli Profil Kesitleri

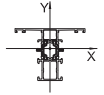

***55-9052/9124** | 135 ° Dönüş Profili
 1,415 kg/m | 135 ° Corner Profile
 $J_x=22,02 \text{ cm}^4$ | $J_y=9,11 \text{ cm}^4$

55-9052/9124-P | Poliüretan Dolgulu 135° Dönüş Profili
 1,440 kg/m | Polyurethane Filled 135 ° Corner Profile

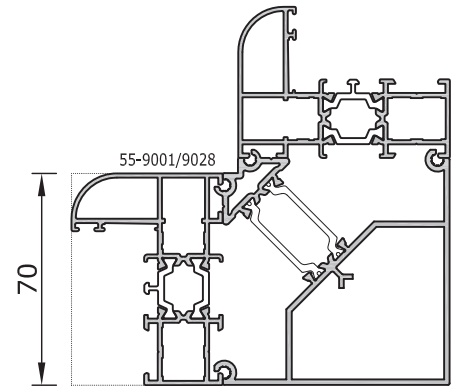
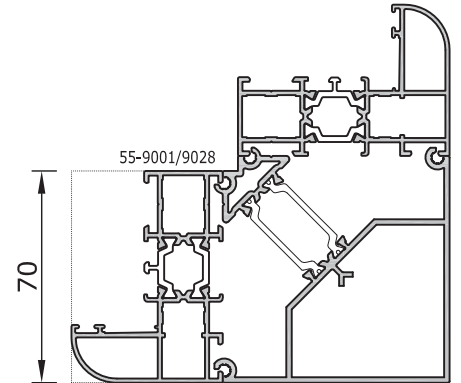
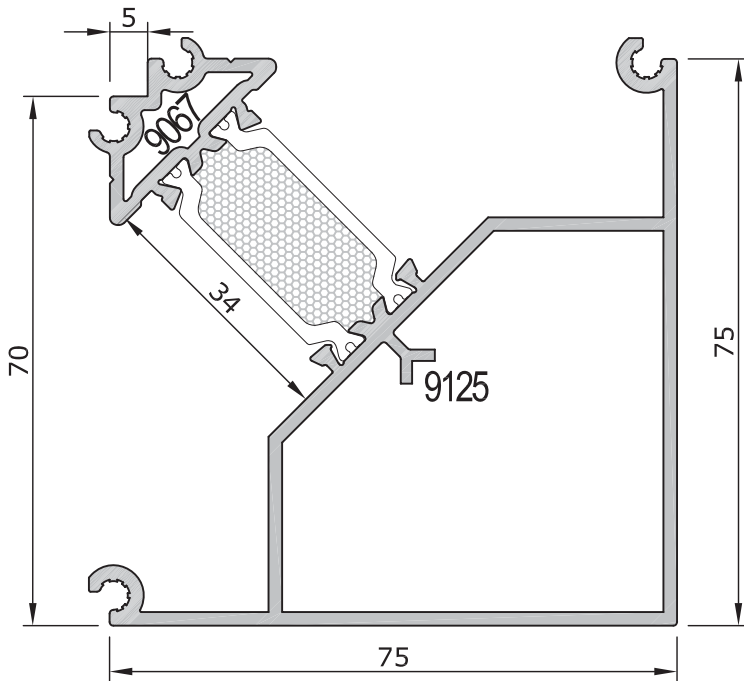
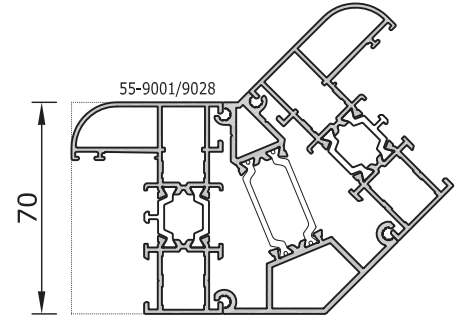
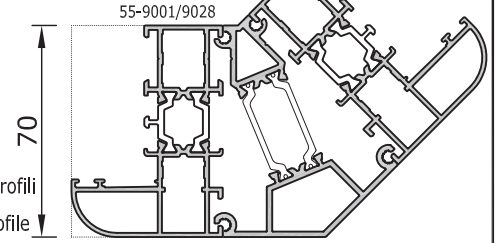
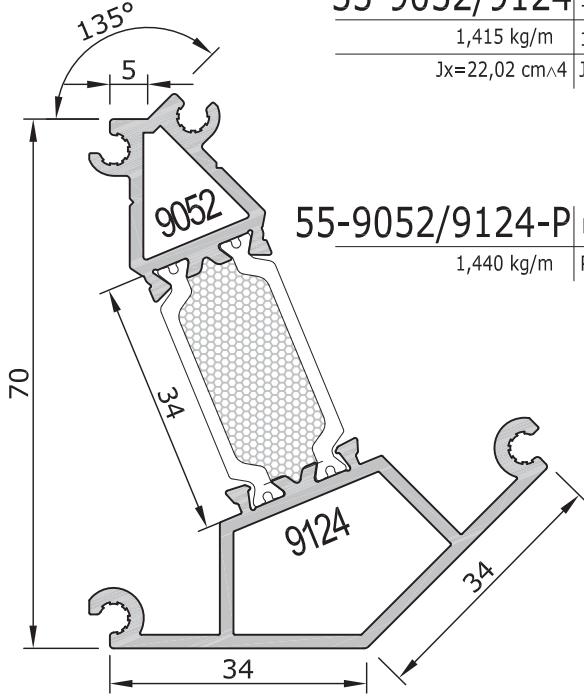

***55-9067/9125** | 90 ° Dönüş Profili
 2.015 kg/m | 90 ° Corner Profile
 $J_x=36,07 \text{ cm}^4$ | $J_y=48,10 \text{ cm}^4$

55-9067/9125-P | Poliüretan Dolgulu 90 ° Dönüş Profili
 2.040 kg/m | Polyurethane Filled 90 ° Corner Profile

* Sipariş miktarı minimum 600 kg dır. / Minimum orde quantity: 600 kg
 Uyarı: Profil ağırlıklarımız teorik olup; teslim anındaki tartımız geçerlidir.
 Warning: the weights of profile is theoretical, weighting at the time of delivery are valid.

Dikkat: Poliüretan doldurulmuş profiller talep üzerine yapılır.
 Minimum sipariş miktarı her bir profil için 100 boydur.
 Warning: Polyurethane infilling is made on request
 Minimum order quantity: 100 bar

Full Scale Sections

Tam Ölçekli Profil Kesitleri

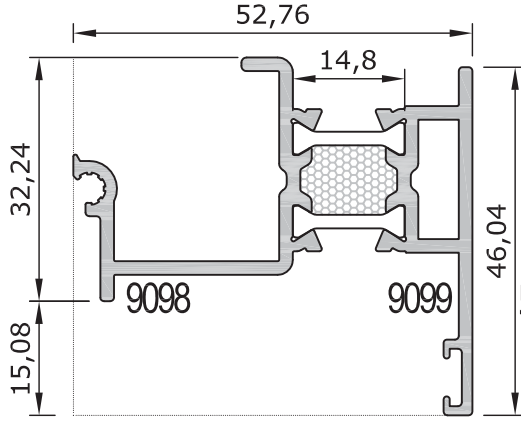
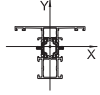

55-9098/9099 İçe Açılır Hemyüz Çift Kanat Adaptörü

1,005 kg/m Inside Opening Door Adapter

Jx=6,87 cm⁴ Jy=3,70 cm⁴

55-9098/9099-P Poliüretan Dolgulu İçe Açılır Hemyüz Çift Kanat Adaptörü

1,010 kg/m Polyurethane Filled Inside Opening Door Adapter

Jx=6,87 cm⁴ Jy=3,70 cm⁴

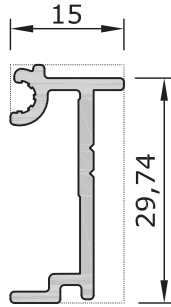

9100 İçe Açılır Hemyüz Kapı Adaptörü

0,295 kg/m Inside Opening Door Adapter

Jx=1,24 cm⁴ Jy=0,13 cm⁴

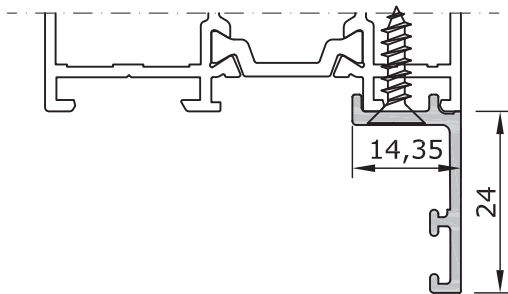

9138 Tırnak Profili

0,200 kg/m Glazing Bead Profile for Exterior

Dikkat: Poliüretan doldurulmuş profiller talep üzerine yapılır.
Minimum sipariş miktarı her bir profil için 100 boydur.
Warning: Polyurethane infilling is made on request
Minimum order quantity: 100 bar

Uyarı: Profil ağırlıklarımız teorik olup; teslim anındaki tartımız geçerlidir.

Warning: the weights of profile is theoretical, weighting at the time of delivery are valid.

Full Scale Sections

Tam Ölçekli Profil Kesitleri

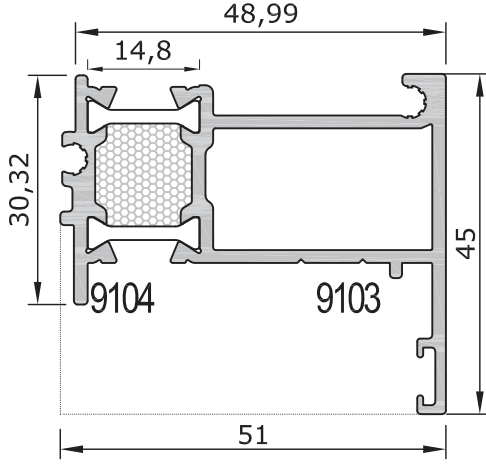
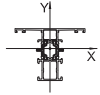

55-9103/9104	Dışa Açılır Hemyüz Çift Kanat Adaptörü
1,065 kg/m	Outside Opening Door Adapter
Jx=9,04 cm ⁴	Jy=4,04 cm ⁴

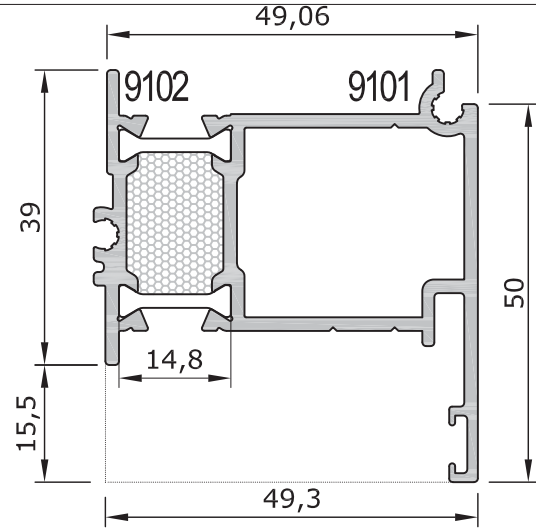

55-9101/9102	Dışa Açılır Hemyüz Kapı Adaptörü
1,195 kg/m	Outside Opening Door Adapter
Jx=10,27 cm ⁴	Jy=6,95 cm ⁴

55-9103/9104-P	Poliüretan Dolgulu Dışa Açılır Hemyüz Çift Kanat Adaptörü
1,065 kg/m	Polyurethane Filled Outside Opening Door Adapter
Jx=9,04 cm ⁴	Jy=4,04 cm ⁴

55-9101/9102-P	Poliüretan Dolgulu Dışa Açılır Hemyüz Kapı Adaptörü
1,210 kg/m	Polyurethane Filled Outside Opening Door Adapter
Jx=10,27 cm ⁴	Jy=6,95 cm ⁴

Dikkat: Poliüretan doldurulmuş profiller talep üzerine yapılır.
Minimum sipariş miktarı her bir profil için 100 boydur.
Warning: Polyurethane infilling is made on request
Minimum order quantity: 100 bar

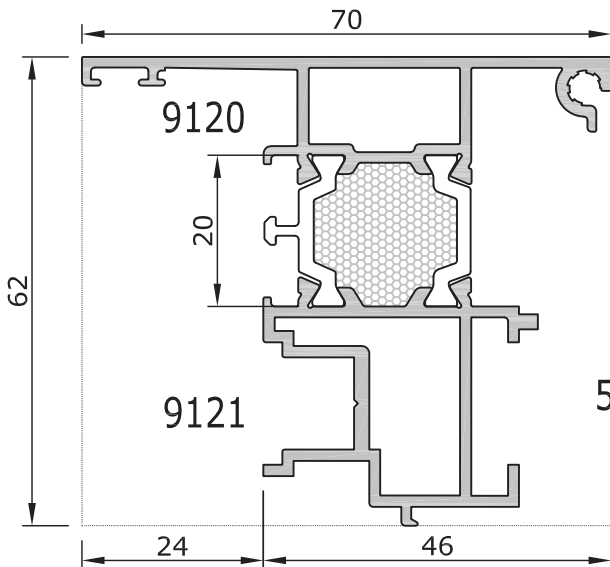

55-9120/9121	PVC Uyumlu Çift Kanat Adaptörü
1,340 kg/m	Double Sash Adapter
Jx=15,36 cm ⁴	Jy=10,37 cm ⁴

55-9120/9121-P	Poliüretan Dolgulu PVC Uyumlu Çift Kanat Adaptörü
1,360 kg/m	Polyurethane Filled Double Sash Adapter

*55-9120/9121 nolu adaptör profili 55-9111/9112, 55-9113/9114 ve 55-9065/9066 nolu PVC uyumlu kanat profilleri ile kullanılır.

Uyarı: Profil ağırlıklarımız teorik olup; teslim anındaki tartımız geçerlidir.

Warning: the weights of profile is theoretical, weighting at the time of delivery are valid.

Full Scale Sections

Tam Ölçekli Profil Kesitleri

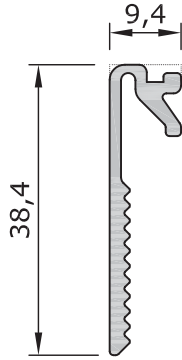

9140** | Pervaz Adaptör Profili
0,290 kg/m | Adapter Profile for Molding
 $J_x=1,50 \text{ cm}^4$ | $J_y=0,08 \text{ cm}^4$

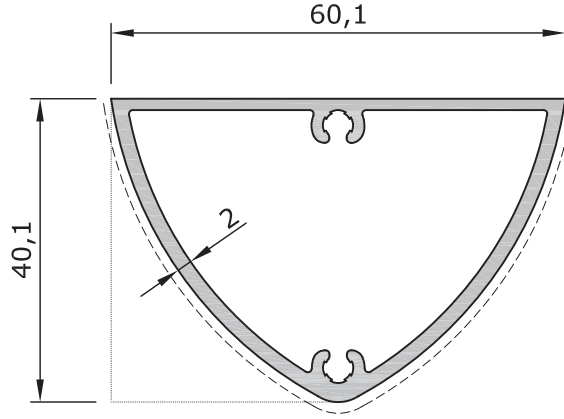

9142** | Orta Kayıt Takviye Profili
0,865 kg/m | Reinforced Profile for Transom
 $J_x=6,07 \text{ cm}^4$ | $J_y=9,66 \text{ cm}^4$

300 mm ara ile kullanılır. Kesim ölçüsü= 50 mm dir.

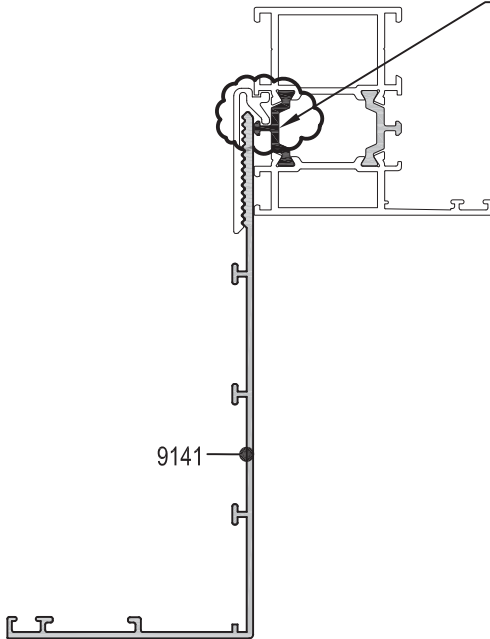

Dikkat: 9140 nolu adaptör profilinin kullanılacağı tüm kasa profillerinde iki tarafa da T ısı bariyeri kullanılması zorunludur. Siparişlerde mutlaka belirtilmesi gerekmektedir.

877 | Tij Profili
0,130 kg/m | Tij Profile

** Sipariş miktarı minimum 300 kg dır. / Minimum orde quantity: 300 kg

Uyarı: Profil ağırlıklarımız teorik olup; teslim anındaki tartımız geçerlidir.

Warning: the weights of profile is theoretical, weighting at the time of delivery are valid.

Full Scale Sections

Tam Ölçekli Profil Kesitleri

9143** 210 mm Pervaz Profili
1,770 kg/m 210 mm Molding Profile
Jx=316,26 cm⁴ Jy=30,41 cm⁴

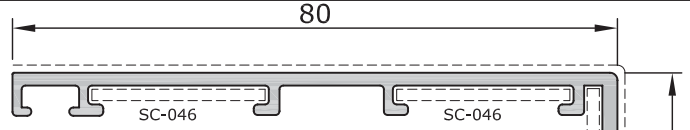

9141** 139 mm Pervaz Profili
1,155 kg/m 139 mm Molding Profile
Jx=94,54 cm⁴ Jy=15,52 cm⁴

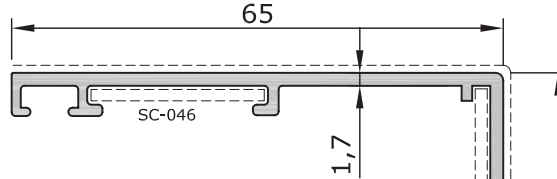

Profil no: 1428
50x50/2 mm köşebent veya
Profil no:1408
40x40/2 mm köşebent
kesim boyu 35 mm

Profil no: 1428
50x50/2 mm köşebent veya
Profil no:1408
40x40/2 mm köşebent
kesim boyu 35 mm

Profil no: 1428
50x50/2 mm köşebent veya
Profil no:1408
40x40/2 mm köşebent
kesim boyu 35 mm

Profil no: 1428
50x50/2 mm köşebent veya
Profil no:1408
40x40/2 mm köşebent
kesim boyu 35 mm

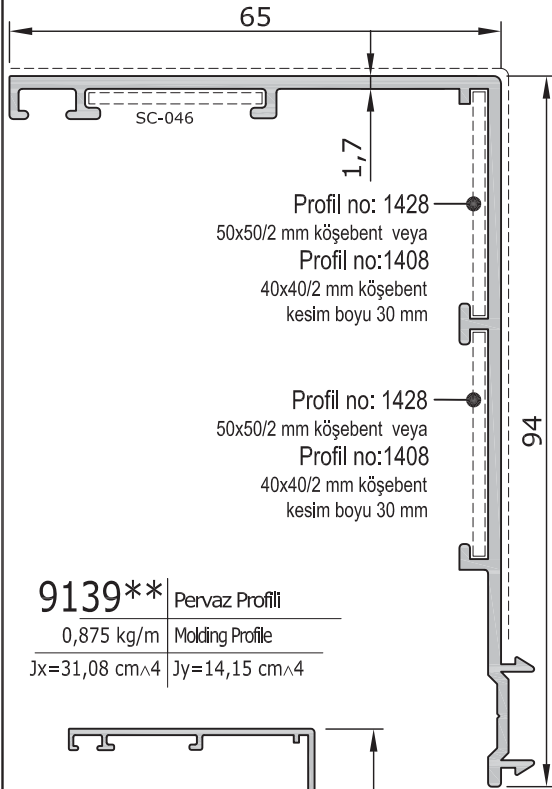

Profil no: 1428
50x50/2 mm köşebent veya
Profil no:1408
40x40/2 mm köşebent
kesim boyu 30 mm

Profil no: 1428
50x50/2 mm köşebent veya
Profil no:1408
40x40/2 mm köşebent
kesim boyu 30 mm

Profil no: 1428
50x50/2 mm köşebent veya
Profil no:1408
40x40/2 mm köşebent
kesim boyu 30 mm

Profil no: 1428
50x50/2 mm köşebent veya
Profil no:1408
40x40/2 mm köşebent
kesim boyu 30 mm

Profil no: 1428
50x50/2 mm köşebent veya
Profil no:1408
40x40/2 mm köşebent
kesim boyu 30 mm

9139** Pervaz Profili
0,875 kg/m Molding Profile
Jx=31,08 cm⁴ Jy=14,15 cm⁴

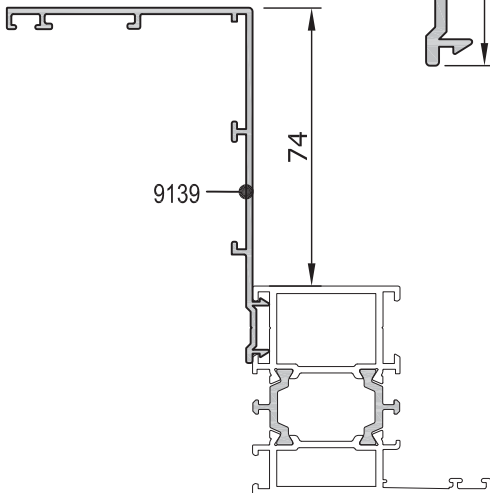

** Sipariş miktarı minimum 300 kg dir. / Minimum orde quantity: 300 kg

Uyarı: Profil ağırlıklarımız teorik olup; teslim anındaki tartımız geçerlidir.

Warning: the weights of profile is theoretical, weighting at the time of delivery are valid.

Full Scale Sections

Tam Ölçekli Profil Kesitleri

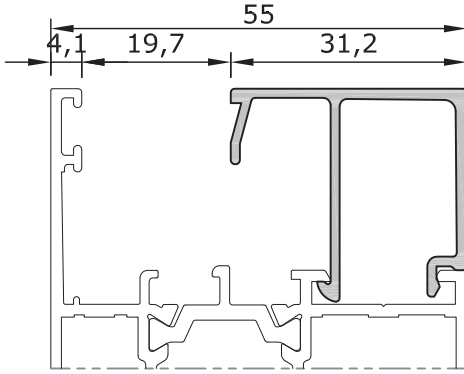

9050

31,2 mm Cam Çıtası
0,352 kg/m

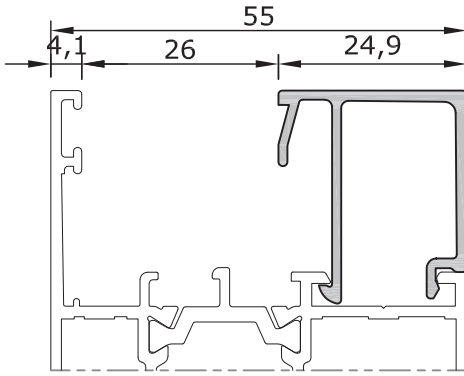
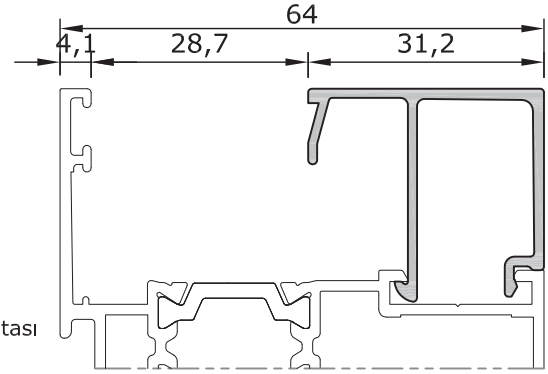

9048

24,9 mm Cam Çıtası
0,340 kg/m

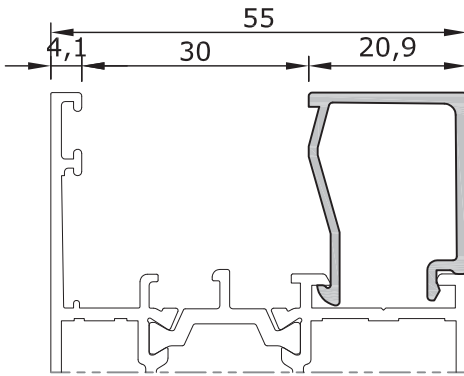
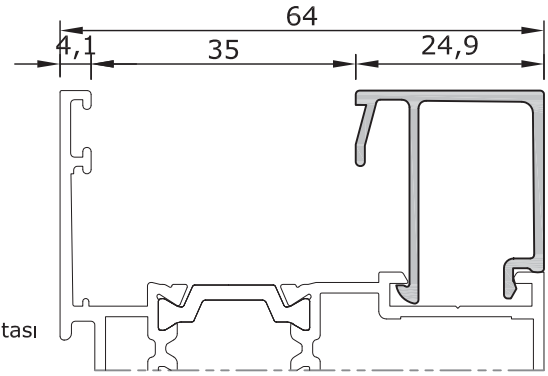

9074

20,9 mm Cam Çıtası
0,300 kg/m

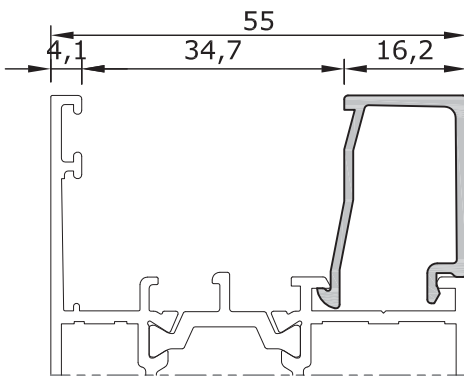
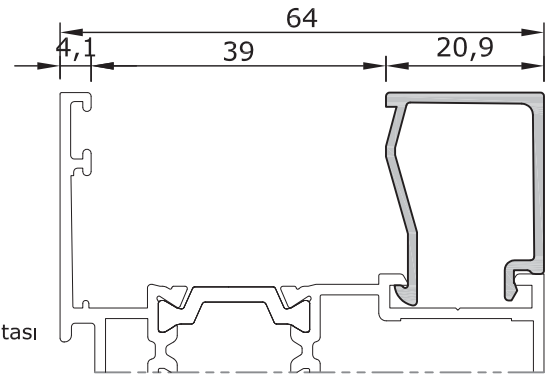

9045

16,2 mm Cam Çıtası
0,280 kg/m

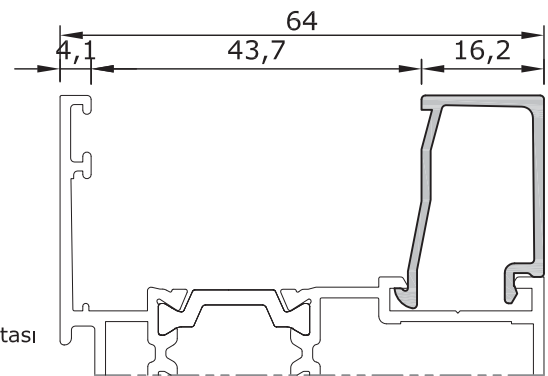

Uyarı: Profil ağırlıklarımız teorik olup; teslim anındaki tartımız geçerlidir.

Warning: the weights of profile is theoretical, weighting at the time of delivery are valid.

Full Scale Sections

Tam Ölçekli Profil Kesitleri

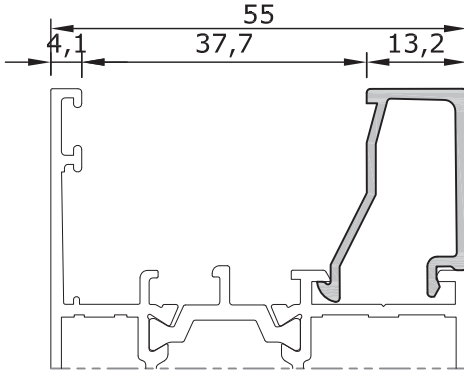

9046
13,2 mm Cam Çıtası
0,263 kg/m

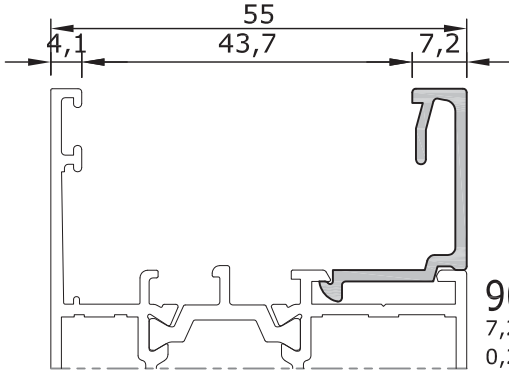
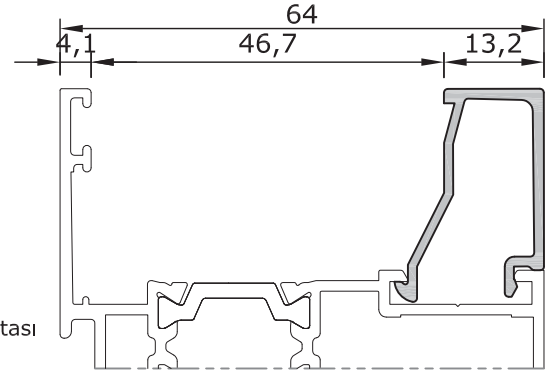

9063
7,2 mm Cam Çıtası
0,250 kg/m

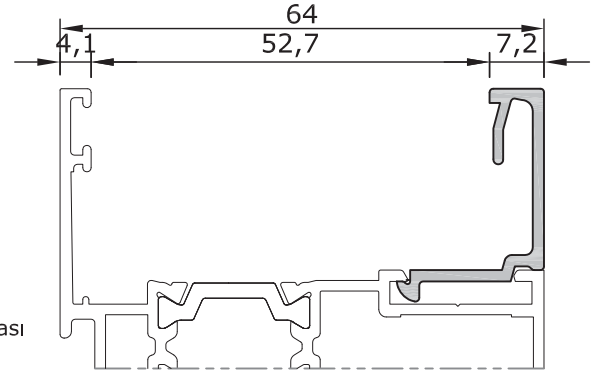

Uyarı: Profil ağırlıklarımız teorik olup; teslim anındaki tartımız geçerlidir.
Warning: the weights of profile is theoretical, weighting at the time of delivery are valid.

Fixed glazing / Overview and selection aluminium glazing bead / interior glazing gasket Sabit cam / Genel bakış ve cam çitası seçenekleri / iç cam çitası

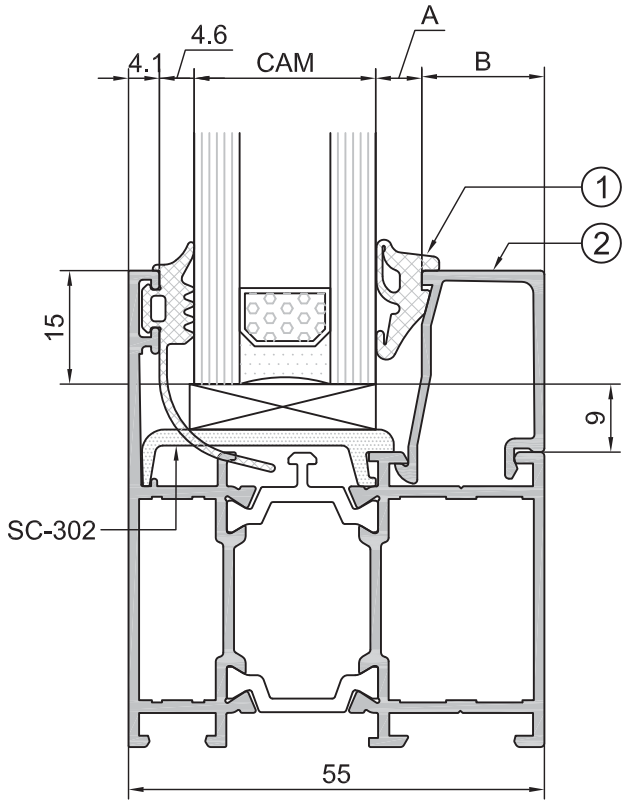

Tabloda gösterilen conta ve boşluklar ile ilgili veriler teoriktir. Lütfen cam ve conta toleranslarının değişkenlik gösterebileceğini dikkate alınız.

CAM mm	CONTA		ÇITA	
	A : mm	①	B : mm	②
20mm	6mm	SC 284	20,9mm	9074
22mm	8mm	SC 282	16,2mm	9045
24mm	6mm	SC 284	16,2mm	9045
26mm	6mm	SC 284	13,2mm	9046
28mm	4.1mm	SC 229	13,2mm	9046
30mm	8mm	SC 282	7,2mm	9063
32mm	6mm	SC 284	7,2mm	9063
34mm	4mm	SC 229	7,2mm	9063

CAM TAKOZLAMA TALİMATI

- ① Taşıyıcı takoz
- ② Ayar takoz

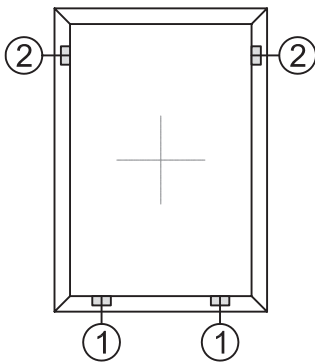

4-5mm	8-9mm	6-7mm	DIŞ CONTA	
SC 229	SC 282	SC 284	SC 108-1	SC 103-1

■ CAM TAKOZU-cam takozları yerleşimi üstte bulunan sematik çizimde gösterilmiştir. takozların kenara mesafeleri kanat ölçüsünün 5/1 i yada 10/1 i kadar olmalıdır.

▨ MESAFE AYARLAMA TAKOZU-mesafe ayar takozları camın alüminyum çerçeve içinde doğru pozisyonda stabil olarak durmasını sağlar. cam ile profil arasına takozları zorlamadan yerleştiriniz.

Takozlar ahşap yada plastik malzemeden yapılabilir. cam takozu sertliği 70-75 shore mesafe ayarlama takozu sertliği 50-60 shore olmalıdır. takoz uzunluğu= Min. 50mm olmalıdır. takoz genişliği=cam kalınlığından büyük olmalı,takoz kalınlığı=belirtilen esit boşluk ölçülerinde

Sash glazing / Overview and selection aluminium glazing bead / interior glazing gasket Kanat camı / Genel bakış ve cam çıtası seçenekleri / iç cam çıtası

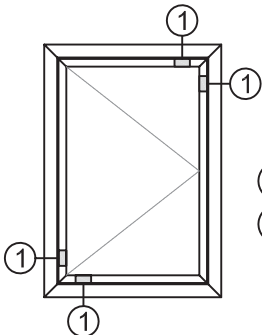
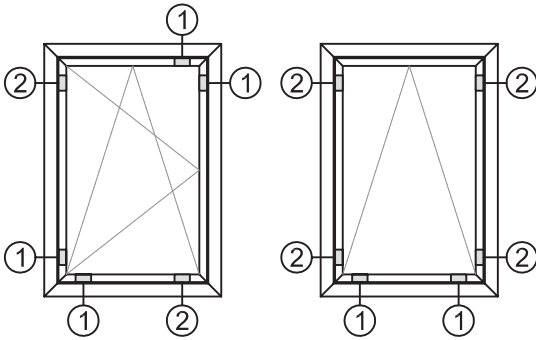
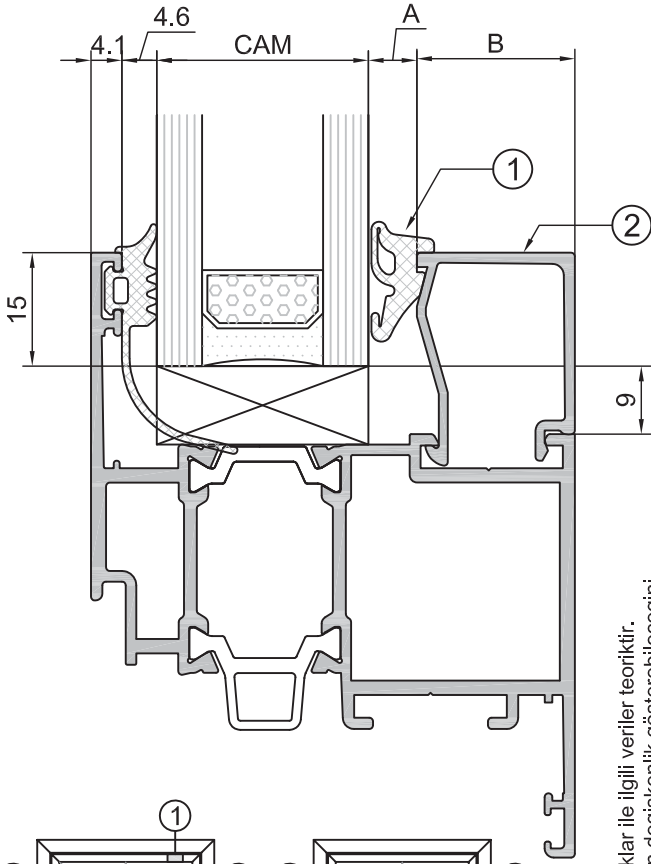





CAM TAKOZLAMA TALİMATI

- ① Taşıyıcı takoz
- ② Ayar takoz

Tabloda gösterilen conta ve boşluklar ile ilgili veriler teoriktir.
Lütfen cam ve conta toleranslarının değişkenlik gösterebileceğini dikkate alınız.

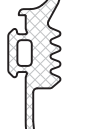
CAM mm	CONTA		ÇITA	
	A : mm	①	B : mm	②
20mm	4mm	SC 229	31,2mm	9050
22mm	8mm	SC 282	24,9mm	9048
24mm	6mm	SC 284	24,9mm	9048
26mm	8mm	SC 282	20,9mm	9074
28mm	6mm	SC 284	20,9mm	9074
30mm	8mm	SC 282	16,2mm	9045
32mm	6mm	SC 284	16,2mm	9045
34mm	8mm	SC 282	13,2mm	9046
36mm	6mm	SC 284	13,2mm	9046
38mm	4mm	SC 229	13,2mm	9046
40mm	8mm	SC 282	7,2mm	9063
42mm	6mm	SC 284	7,2mm	9063
44mm	4mm	SC 229	7,2mm	9063

4-5mm	8-9mm	6-7mm	DIŞ CONTA	
				
SC 229	SC 282	SC 284	SC 108-1	SC 103-1

■ CAM TAKOZU-cam takozları yerleşimi üstte bulunan sematik çizimde gösterilmiştir. takozların kenara mesafeleri kanat ölçüsünün 5/1 i yada 10/1 i kadar olmalıdır.

▣ MESAFE AYARLAMA TAKOZU-mesafe ayar takozları camin alüminyum çerçeve içinde doğru pozisyonda stabil olarak durmasını sağlar. cam ile profil arasına takozları zorlamadan yerleştiriniz.

Takozlar ahşap yada plastik malzemeden yapılabilir. cam takozu sertliği 70-75 shore mesafe ayarlama takozu sertliği 50-60 shore olmalıdır. takoz uzunluğu= Min. 50mm olmalıdır. takoz genişliği=cam kalınlığından büyük olmalı, takoz kalınlığı=belirtilen esit boşluk ölçülerinde

Sash glazing / Overview and selection aluminium glazing bead / interior glazing gasket Kanat camı / Genel bakış ve cam çitası seçenekleri / iç cam çitası

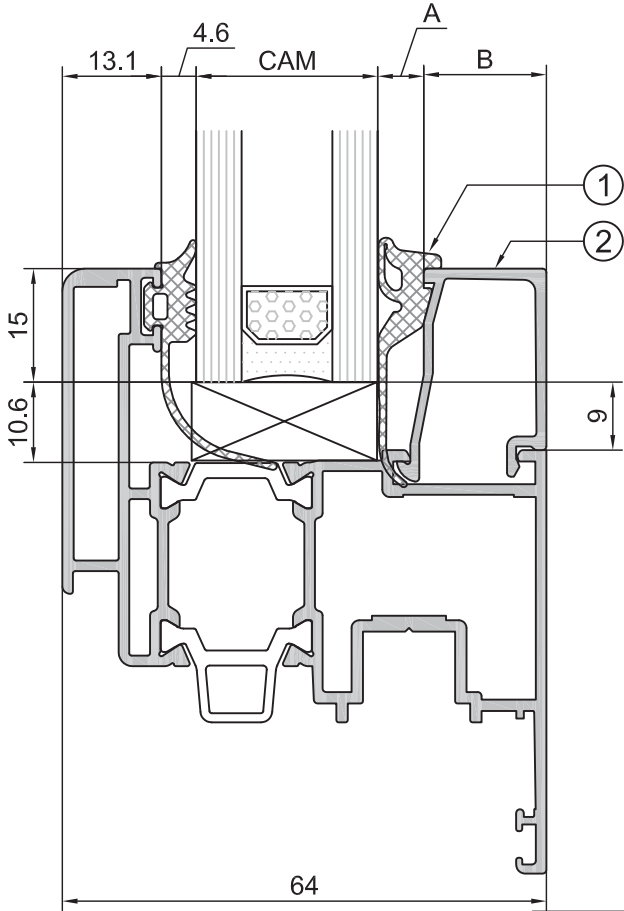

Tabloda gösterilen conta ve boşluklar ile ilgili veriler teoriktir. Lütfen cam ve conta toleranslarının değişkenlik gösterebileceğini dikkate alınız.

CAM mm	CONTA		ÇITA	
	A : mm	①	B : mm	②
20mm	6mm	SC 284	20,9mm	9074
22mm	8mm	SC 282	16,2mm	9045
24mm	6mm	SC 284	16,2mm	9045
26mm	6mm	SC 284	13,2mm	9046
28mm	4.1mm	SC 229	13,2mm	9046
30mm	8mm	SC 282	7,2mm	9063
32mm	6mm	SC 284	7,2mm	9063
34mm	4mm	SC 229	7,2mm	9063

CAM TAKOZLAMA TALİMATI

- ① Taşıyıcı takoz
- ② Ayar takoz

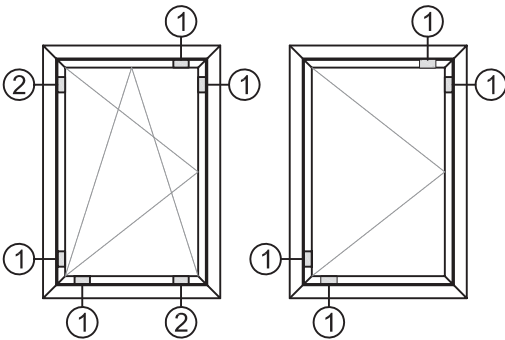

4-5mm	8-9mm	6-7mm	DIŞ CONTA	
SC 229	SC 282	SC 284	SC 108-1	SC 103-1

■ CAM TAKOZU-cam takozları yerleşimi üstte bulunan sematik çizimde gösterilmiştir. takozların kenara mesafeleri kanat ölçüsünün 5/1 i yada 10/1 i kadar olmalıdır.

▨ MESAFE AYARLAMA TAKOZU-mesafe ayar takozları camın alüminyum çerçeve içinde doğru pozisyonda stabil olarak durmasını sağlar. cam ile profil arasına takozları zorlamadan yerleştiriniz.

Takozlar ahşap yada plastik malzemeden yapılabilir. cam takozu sertliği 70-75 shore mesafe ayarlama takozu sertliği 50-60 shore olmalıdır. takoz uzunluğu= Min. 50mm olmalıdır. takoz genişliği=cam kalınlığından büyük olmalı, takoz kalınlığı=belirtilen esit boşluk ölçülerinde

Hidden Sash glazing / Overview and selection aluminium glazing bead / interior glazing gasket Gizli Kanat camı / Genel bakış ve cam çitası seçenekleri / iç cam çitası

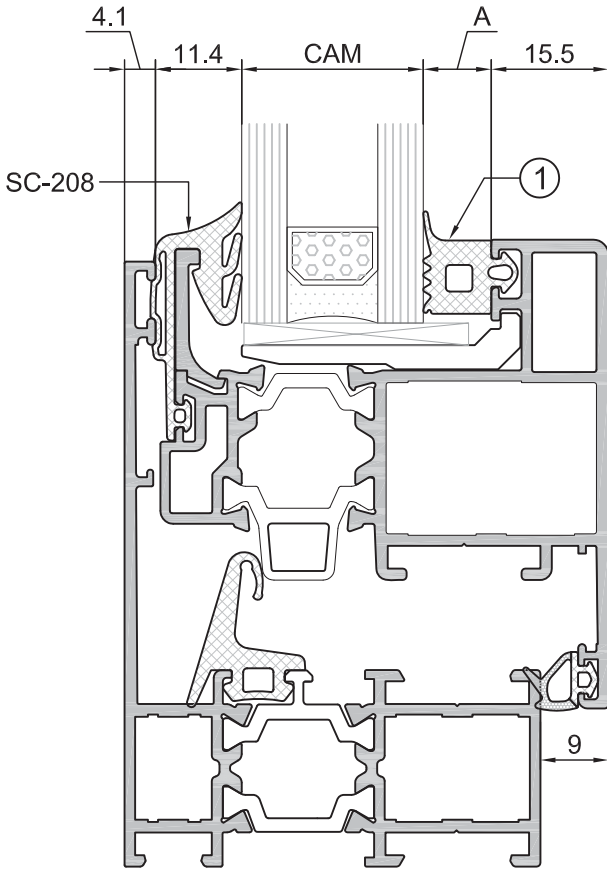

Tabloda gösterilen conta ve boşluklar ile ilgili veriler teoriktir. Lütfen cam ve conta toleranslarının değişkenlik gösterebileceğini dikkate alınız.

CAM	CONTA	
mm	A : mm	①
22mm	11mm	SC 203
24mm	9mm	SC 284
26mm	7mm	SC 205
28mm	5mm	SC 206
30mm	3mm	SC 207

3mm	5mm	7mm	9mm	11mm
SC 207	SC 206	SC 205	SC 204	SC 203

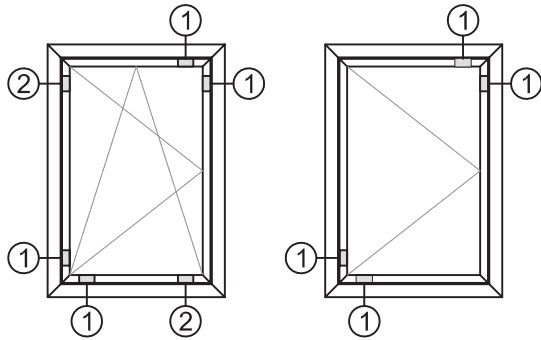

CAM TAKOZLAMA TALİMATI

- ① Taşıyıcı takoz
- ② Ayar takoz

■ CAM TAKOZU-cam takozlari yerlesimi üstte bulunan sematik çizimde gösterilmistir. takozların kenara mesafeleri kanat ölçüsünün 5/1 i yada 10/1 i kadar olmalıdır.

▨ MESAFE AYARLAMA TAKOZU-mesafe ayar takozlari camin alüminyum çerçeve içinde doğru pozisyonda stabil olarak durmasını sağlar. cam ile profil arasına takozlari zorlamadan yerlestiniriz.

Takozlar ahşap yada plastik malzemeden yapılabilir. cam takozu sertligi 70-75 shore mesafe ayarlama takozu sertligi 50-60 shore olmalıdır. takoz uzunlugu= Min. 50mm olmalıdır. takoz genişligi=cam kalınlıgından büyük olmalı,takoz kalınlıgı=belirtilen esit bosluk ölçülerinde

**EW55
WINDOWS and DOORS
SYSTEM
SERIES DETAILS**

**EW55 KAPI ve PENCERE
SİSTEMİ
PRENSİP DETAYLAR**

Typical System Detail
Prensip Sistem Detayları

Detay
Detail 1

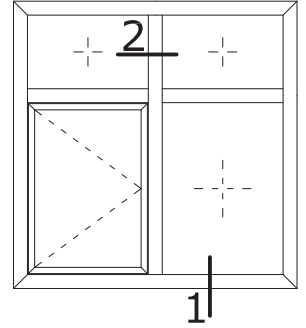
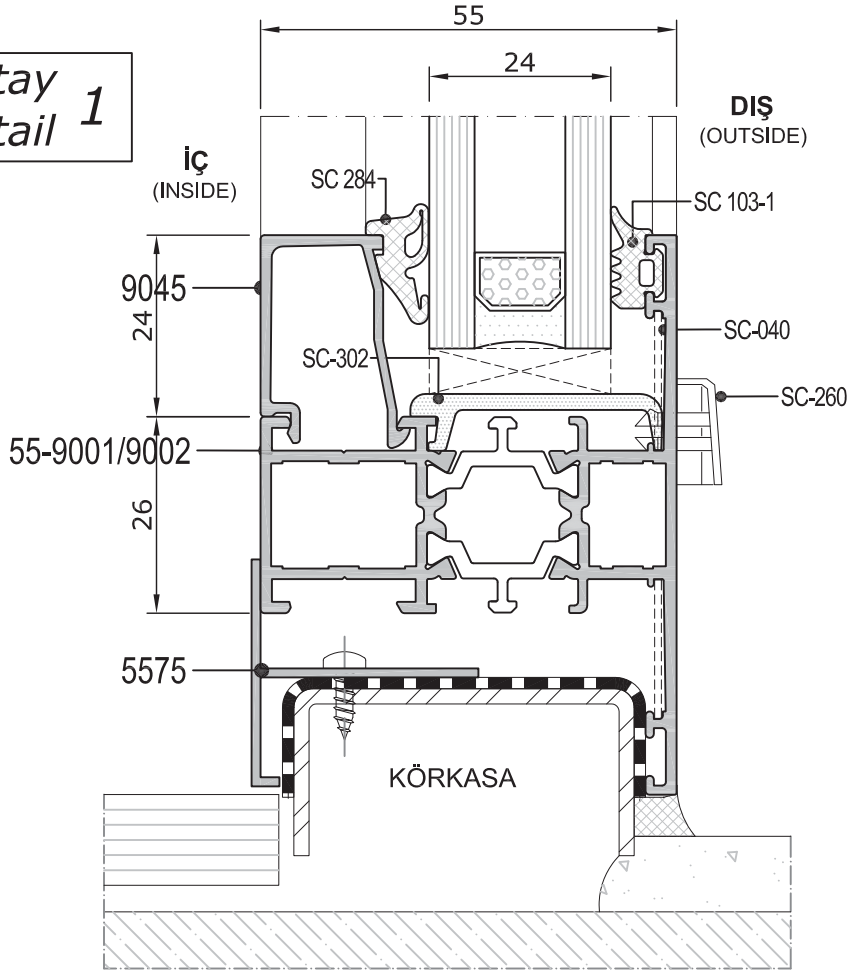

Detay
Detail 2

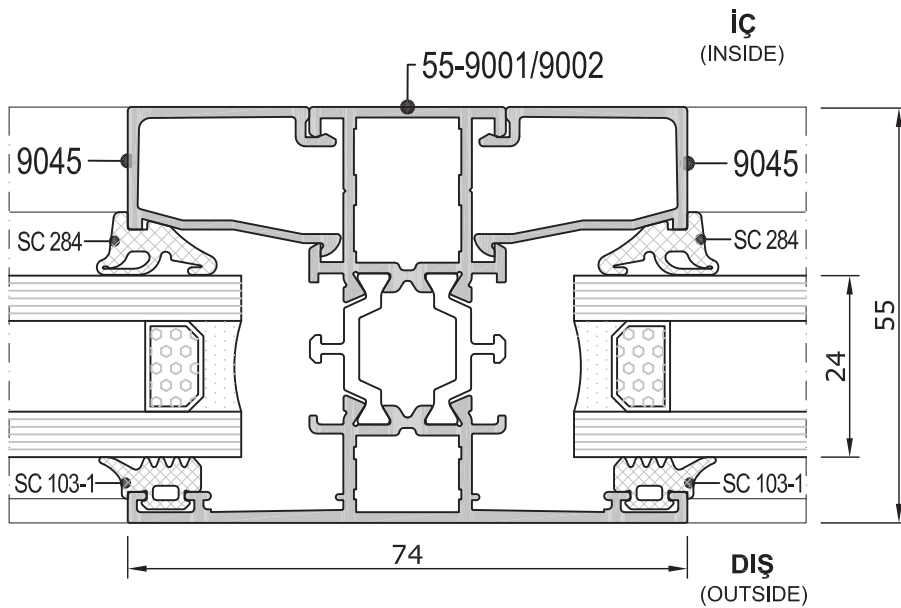

Typical System Detail
Prensip Sistem Detayları

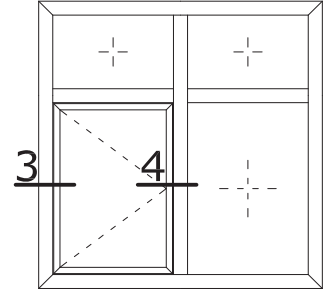

Detay
Detail 3

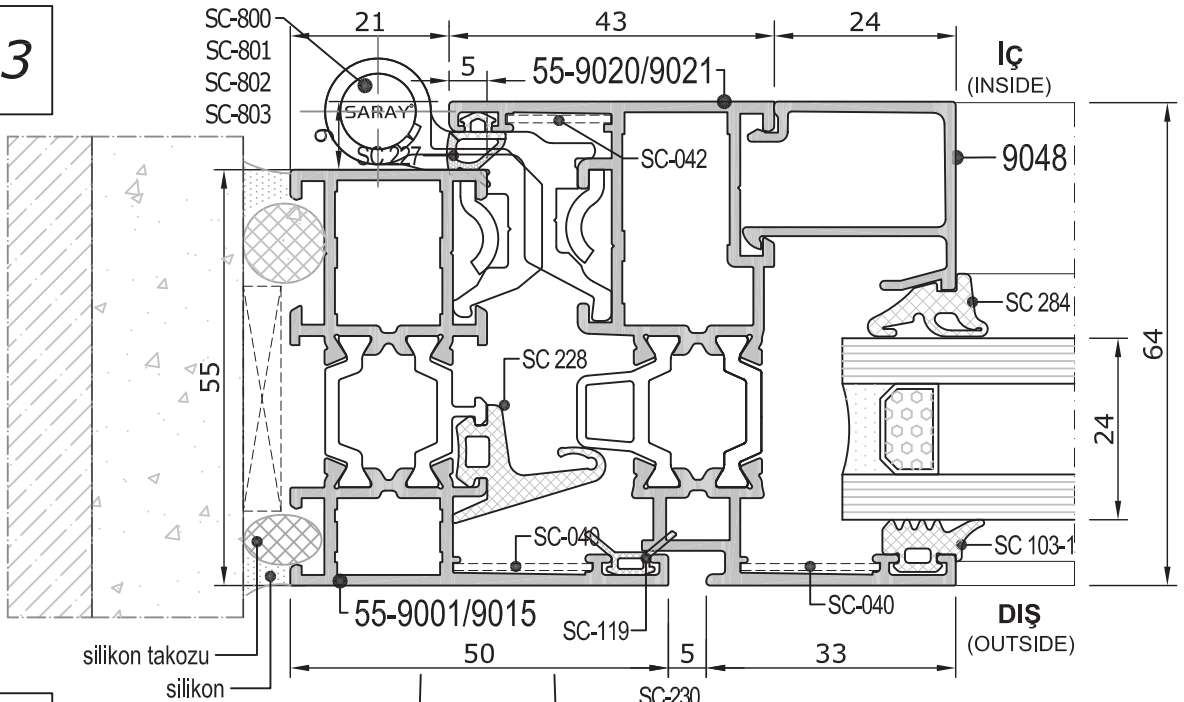

Detay
Detail 4

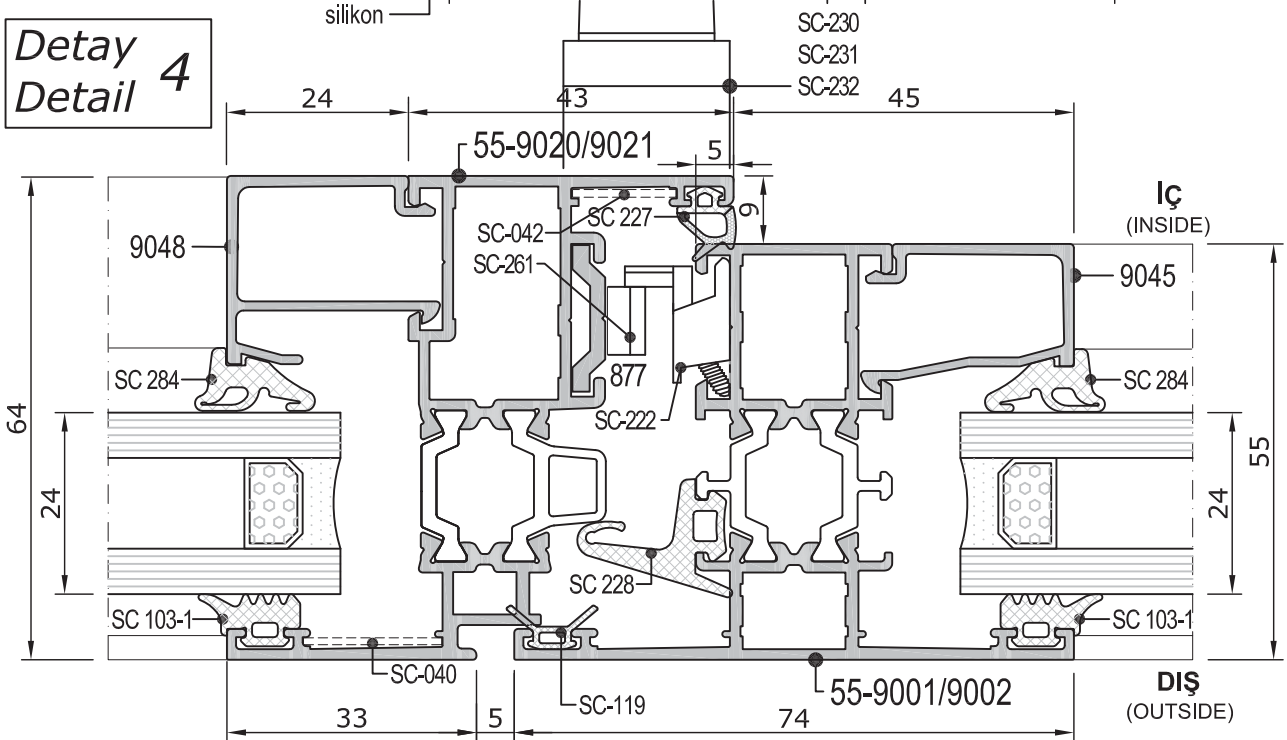

Typical System Detail
Prensip Sistem Detayları

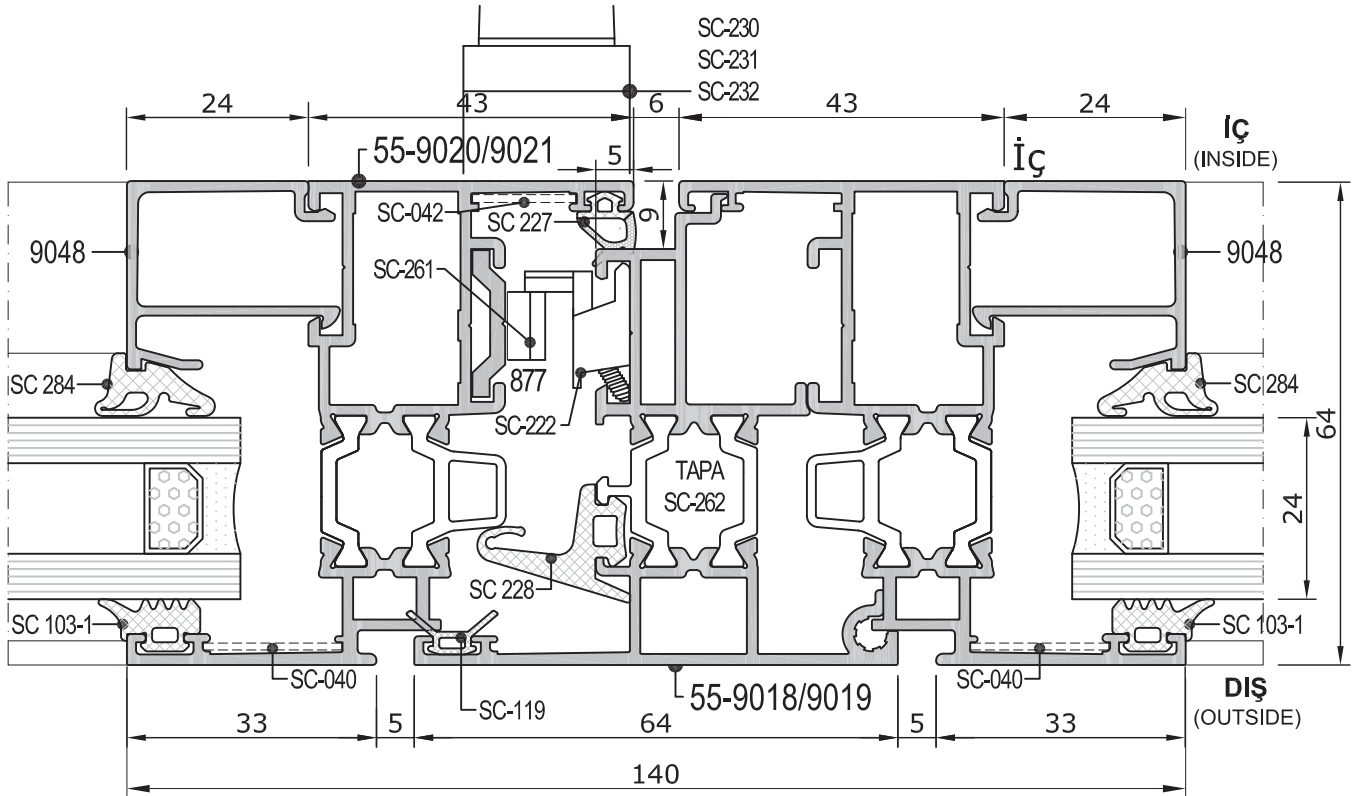
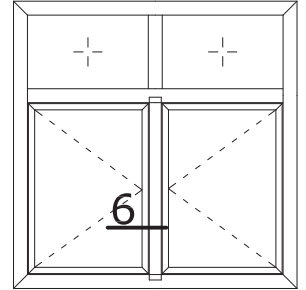

Detay
Detail 6

Typical System Detail
Prensip Sistem Detayları

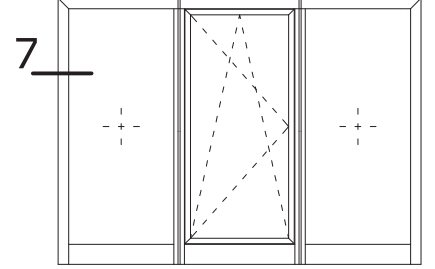

Detay
Detail 7

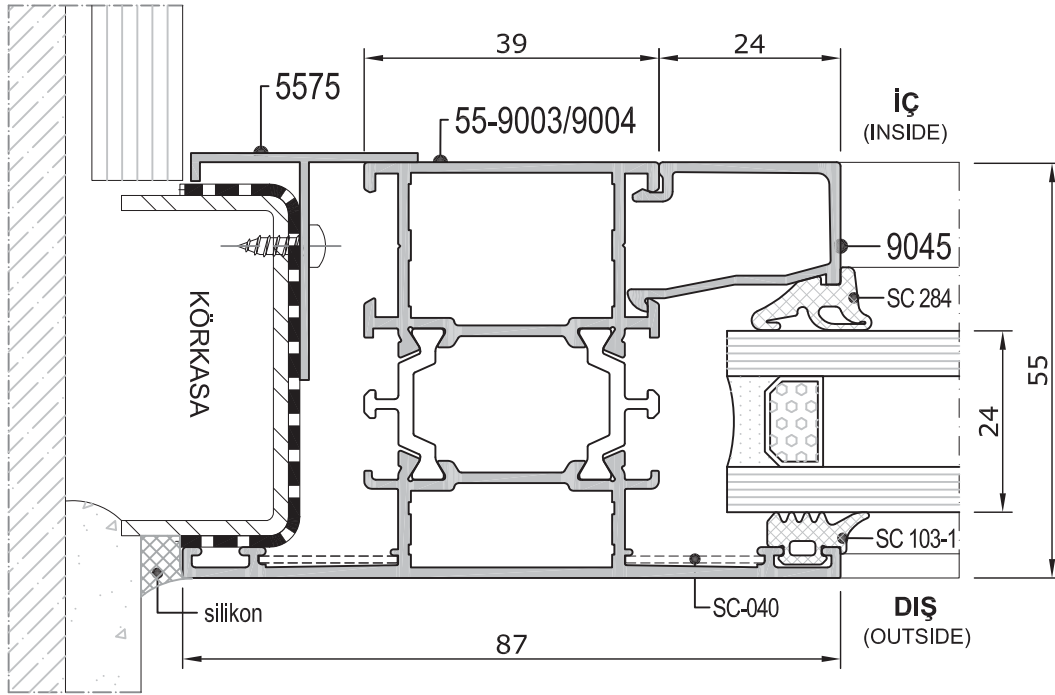

Typical System Detail
Prensip Sistem Detayları

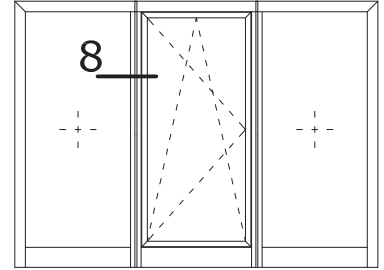

Detay
Detail 8

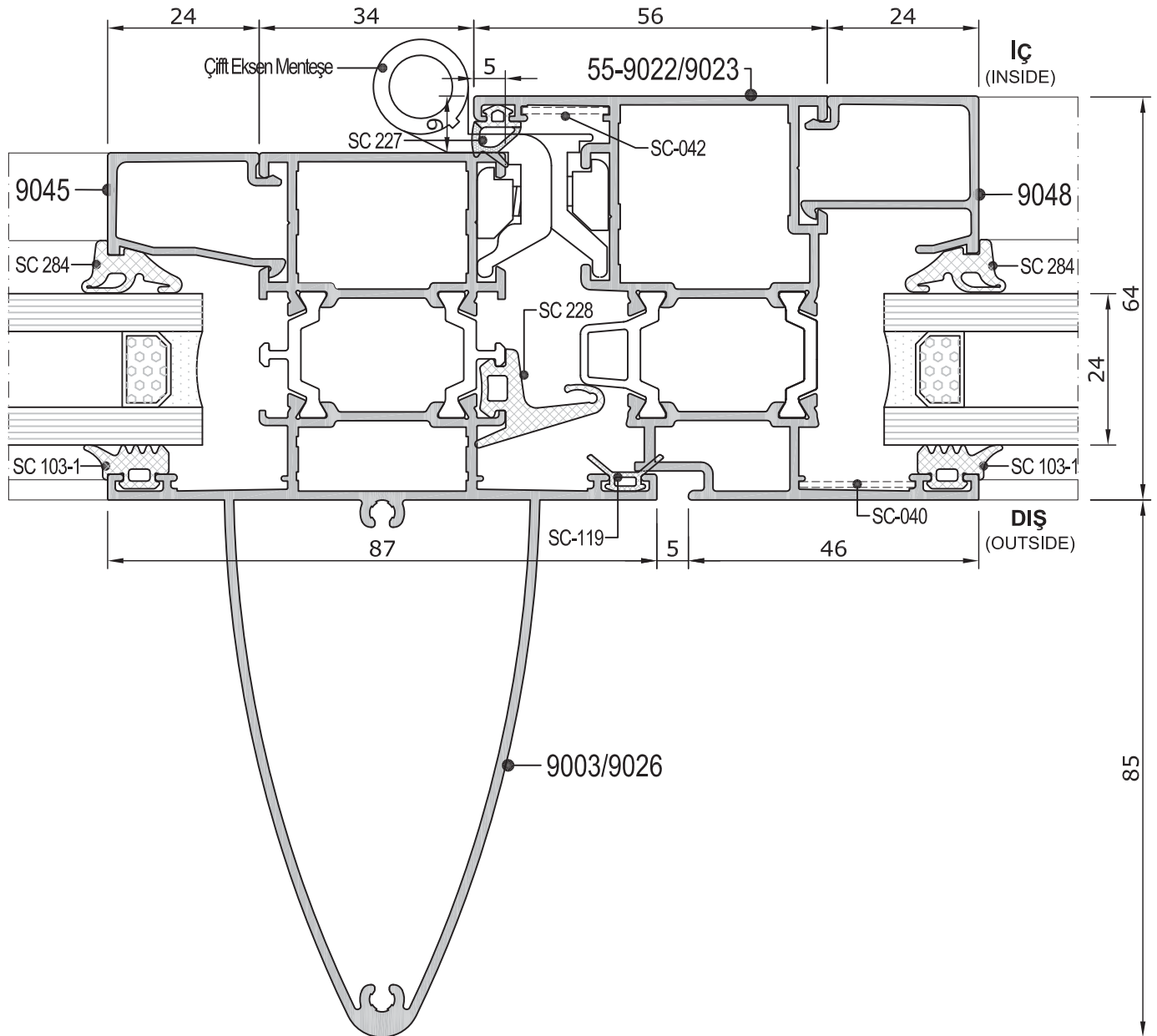

Typical System Detail
Prensip Sistem Detayları

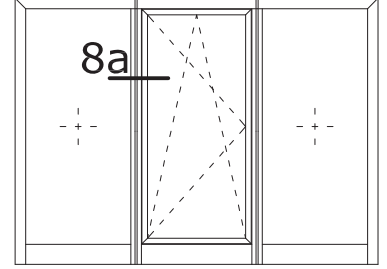

Detay
Detail 8a

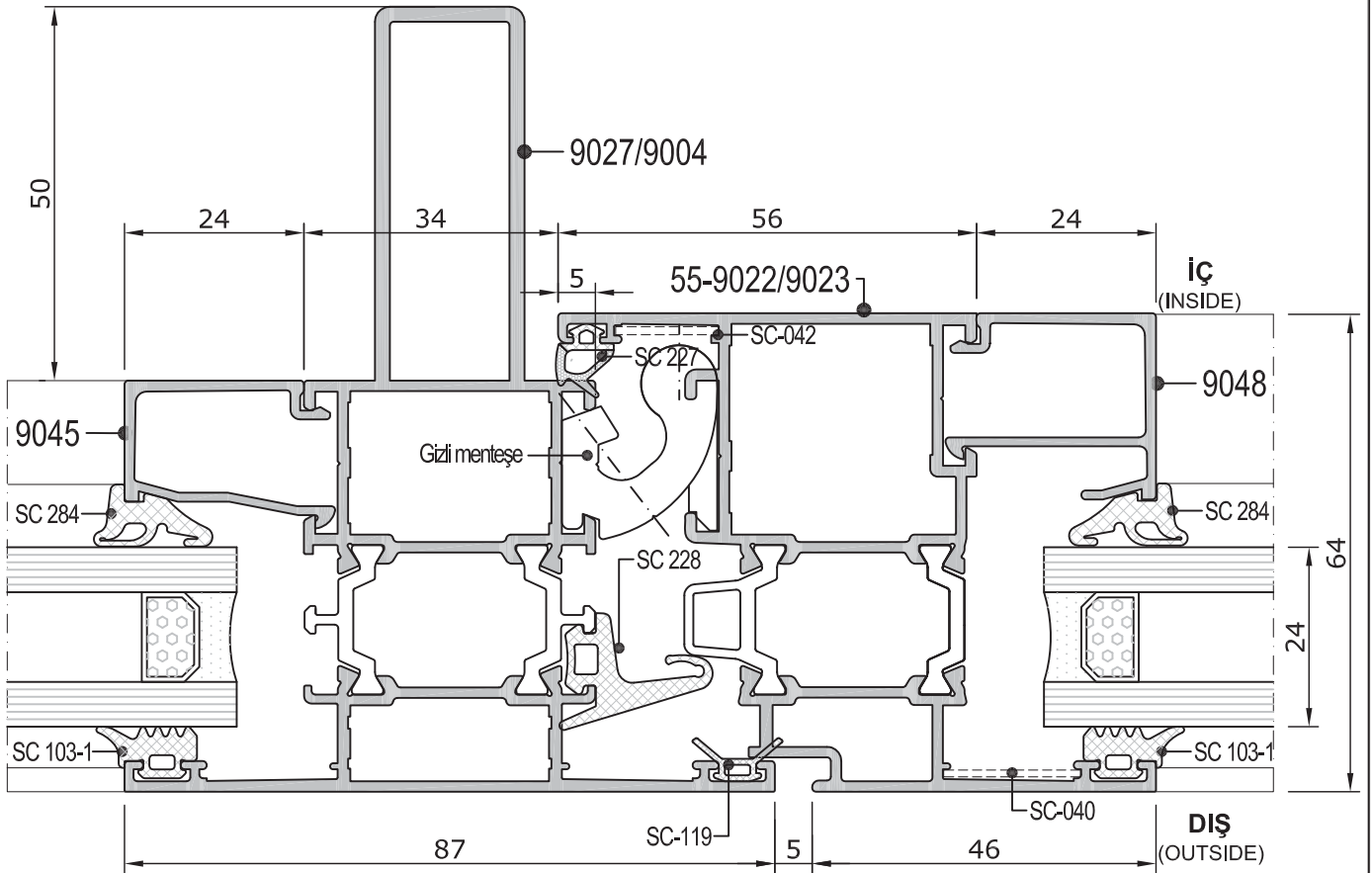

Typical System Detail
Prensip Sistem Detayları

Detay
Detail 9

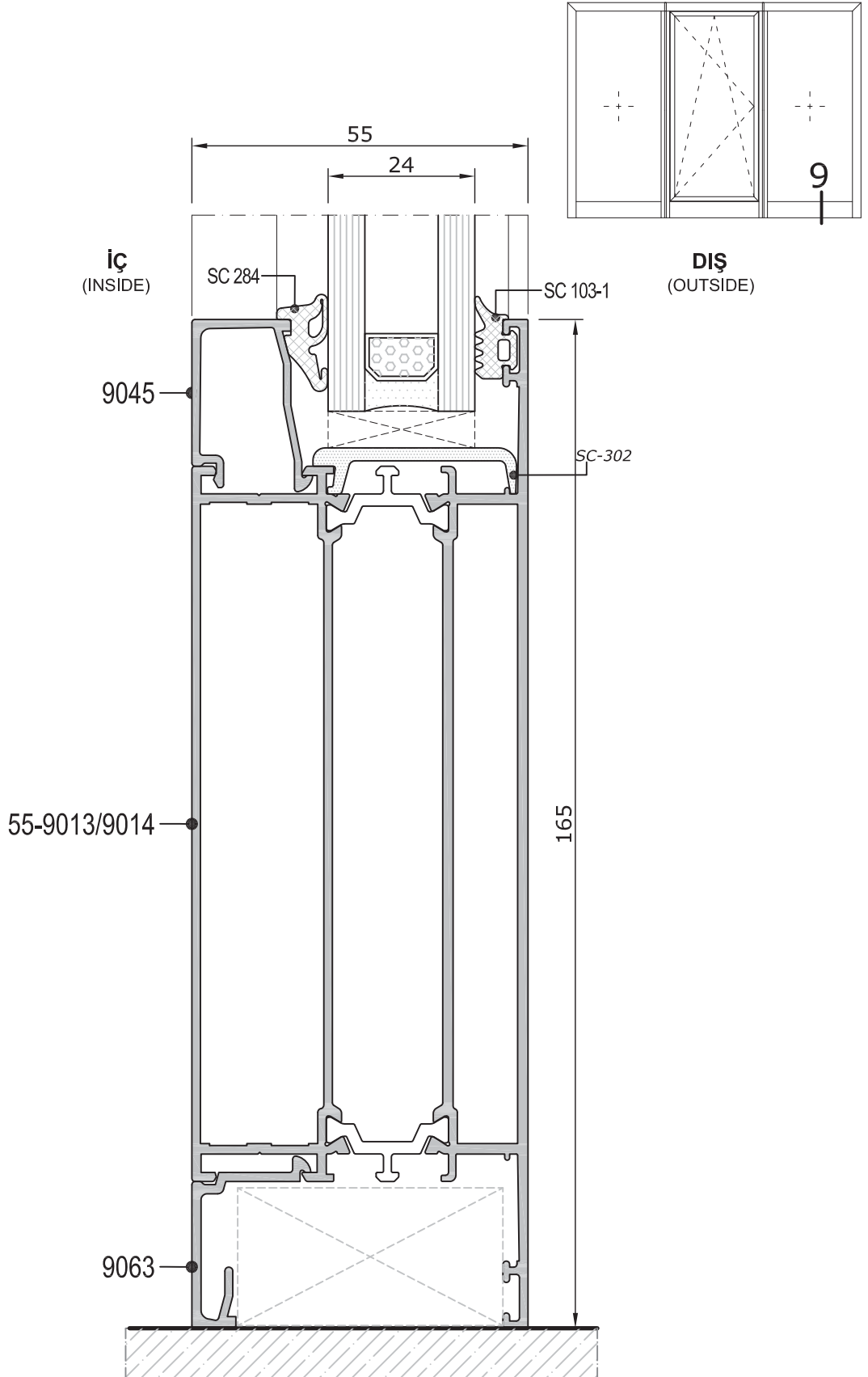

Typical System Detail
Prensip Sistem Detayları

Detay
Detail 10

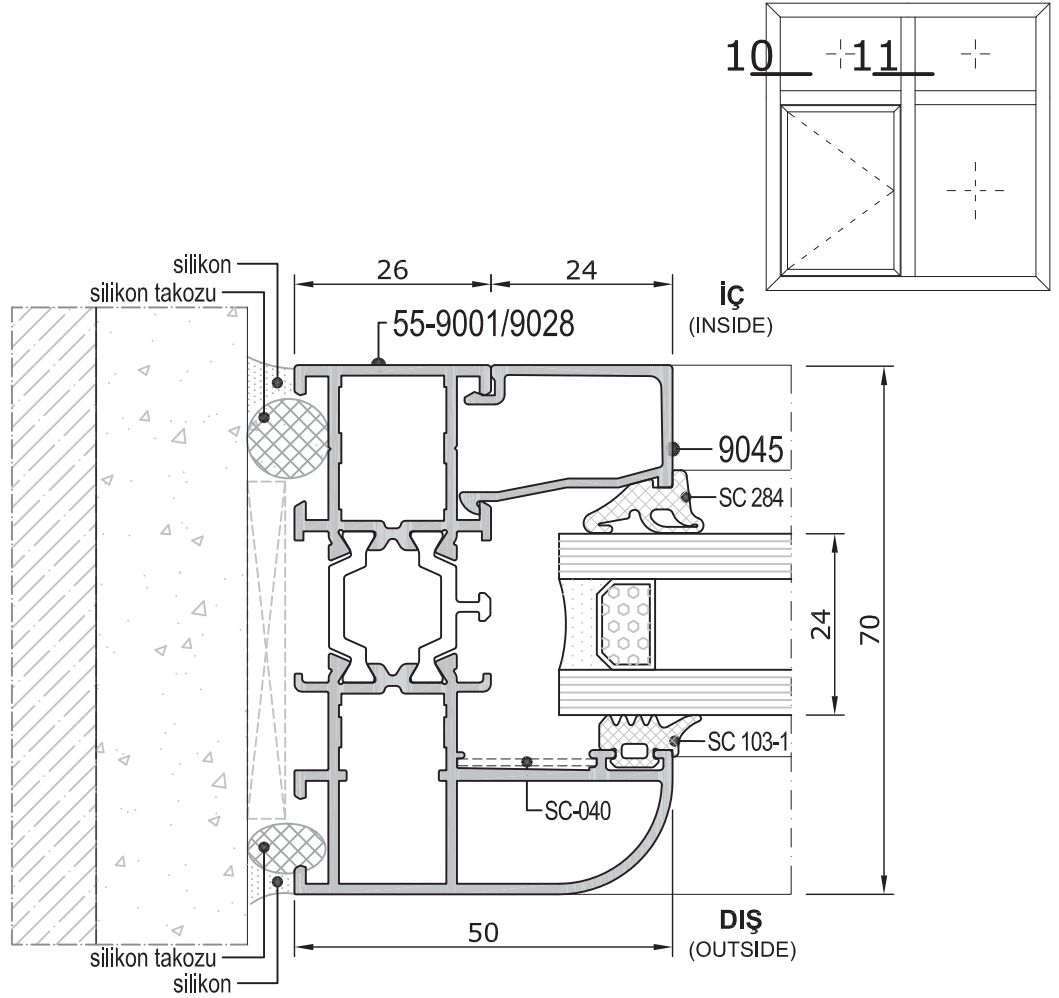

Detay
Detail 11

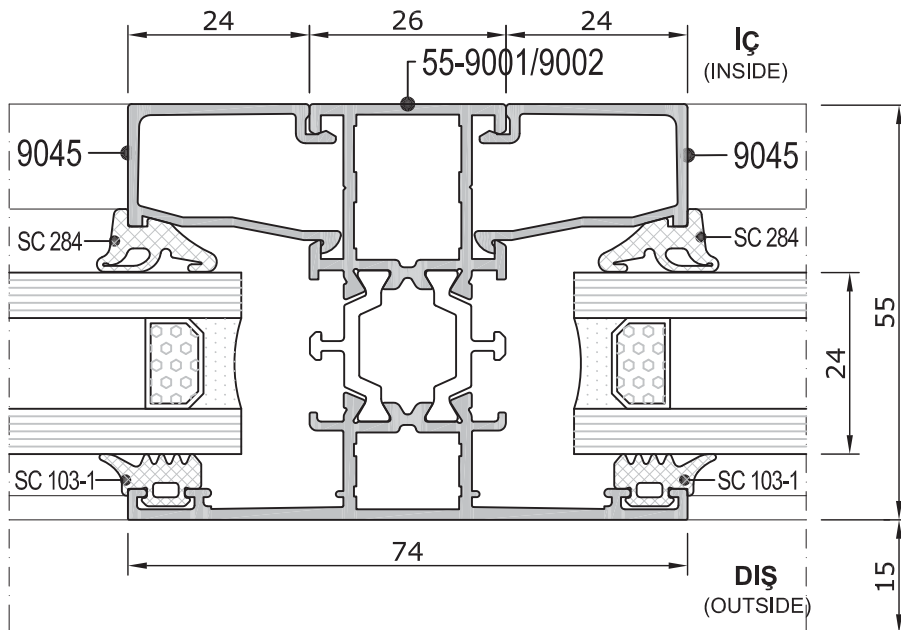

Typical System Detail
Prensip Sistem Detayları

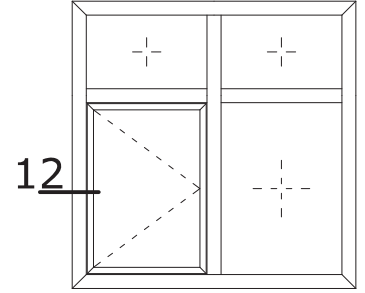

Detay
Detail 12

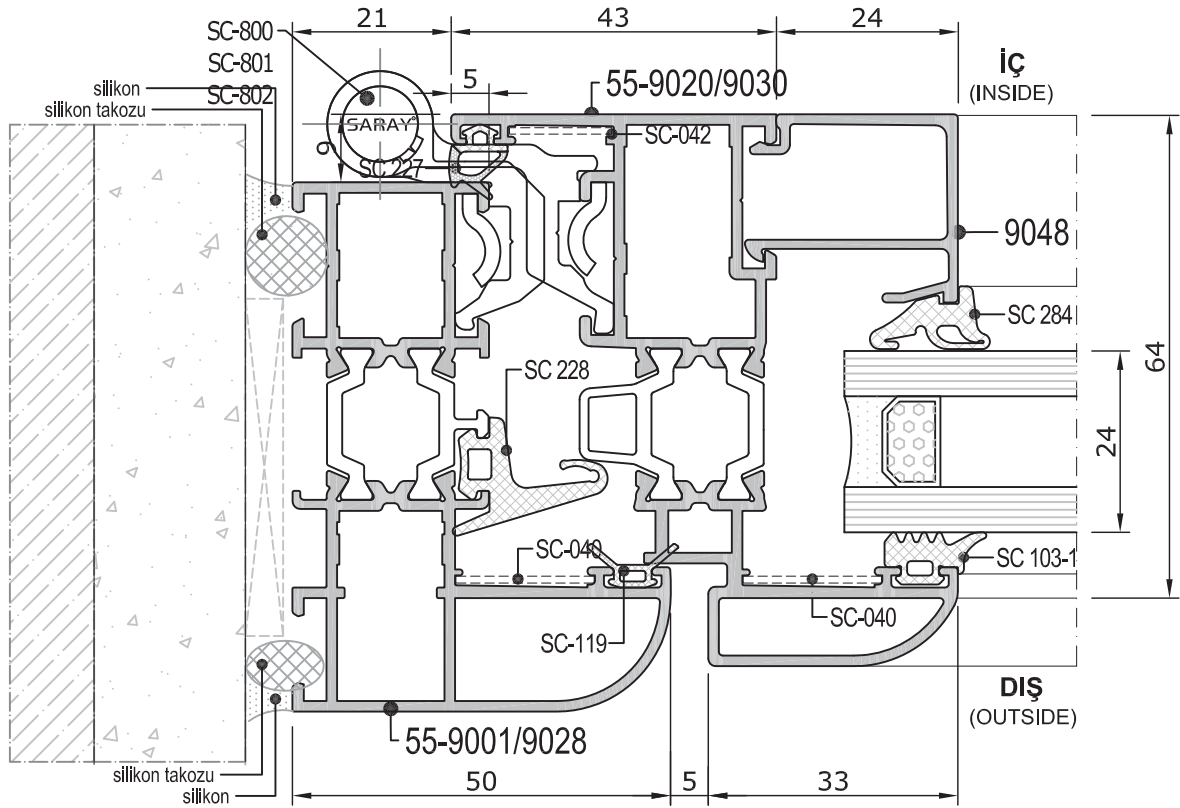

Typical System Detail
Prensip Sistem Detayları

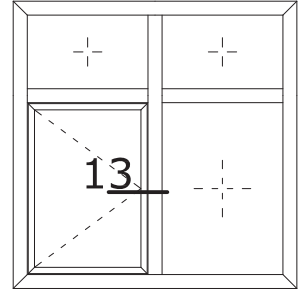

Detay
Detail 13

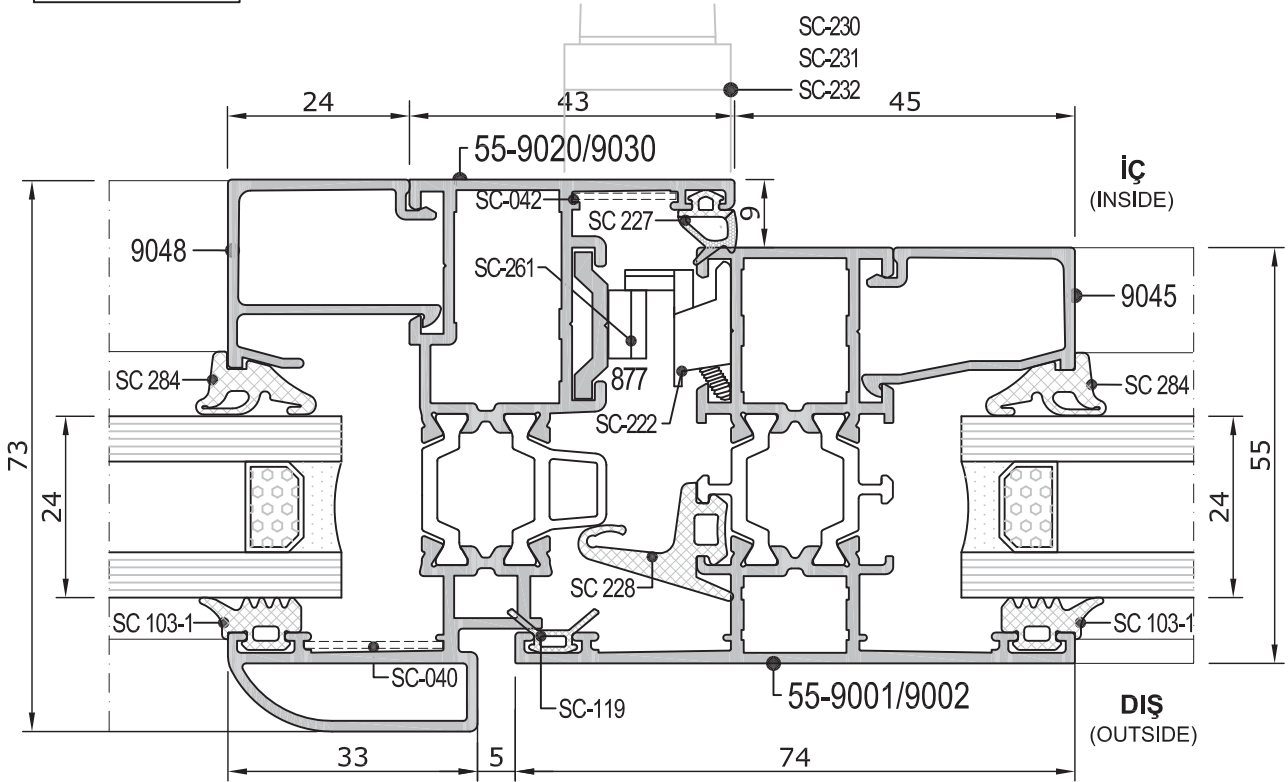

Typical System Detail
Prensip Sistem Detayları

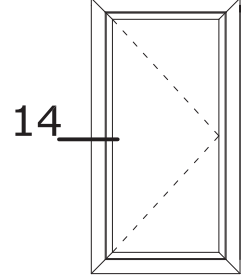

Detay
Detail 14

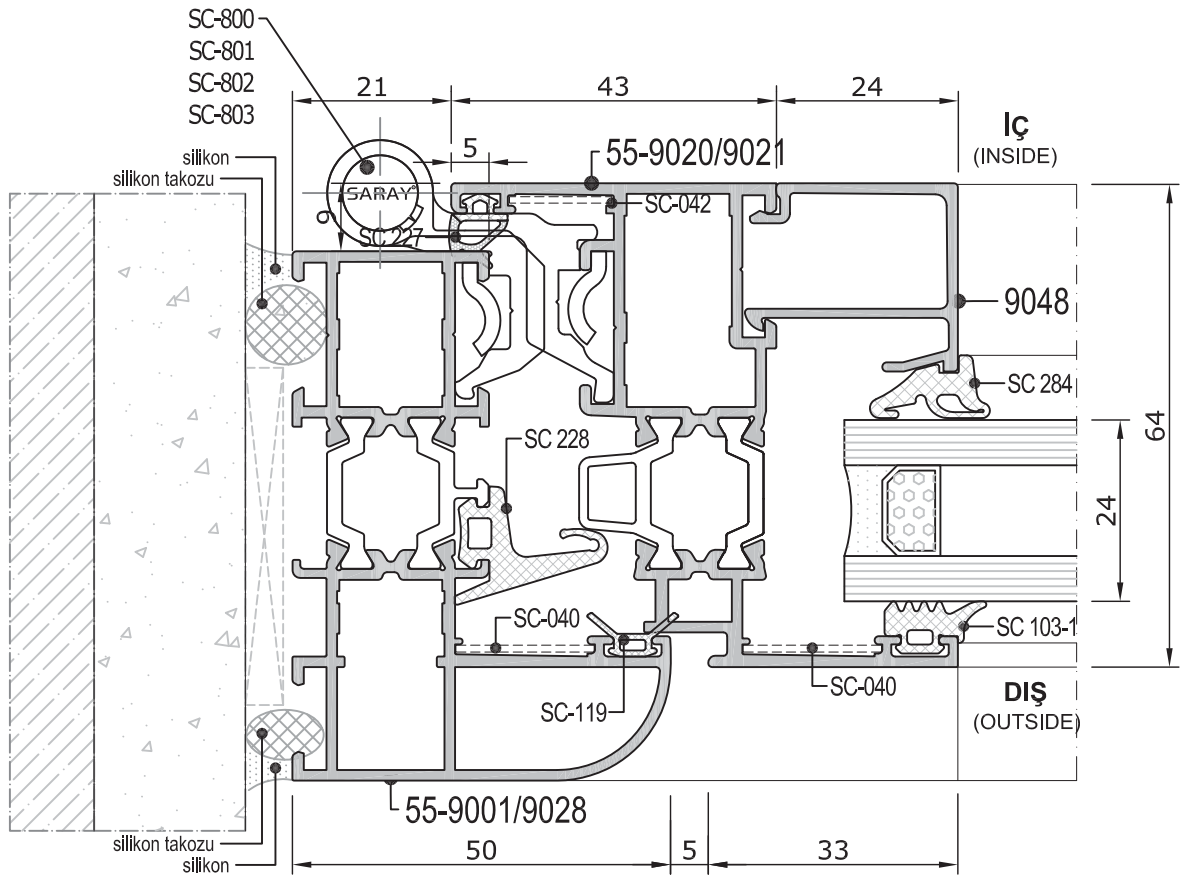

Typical System Detail
Prensip Sistem Detayları

Hidding Sash System Detail
Gizli Kanatlı Sistem Detayı

Detay
Detail 15

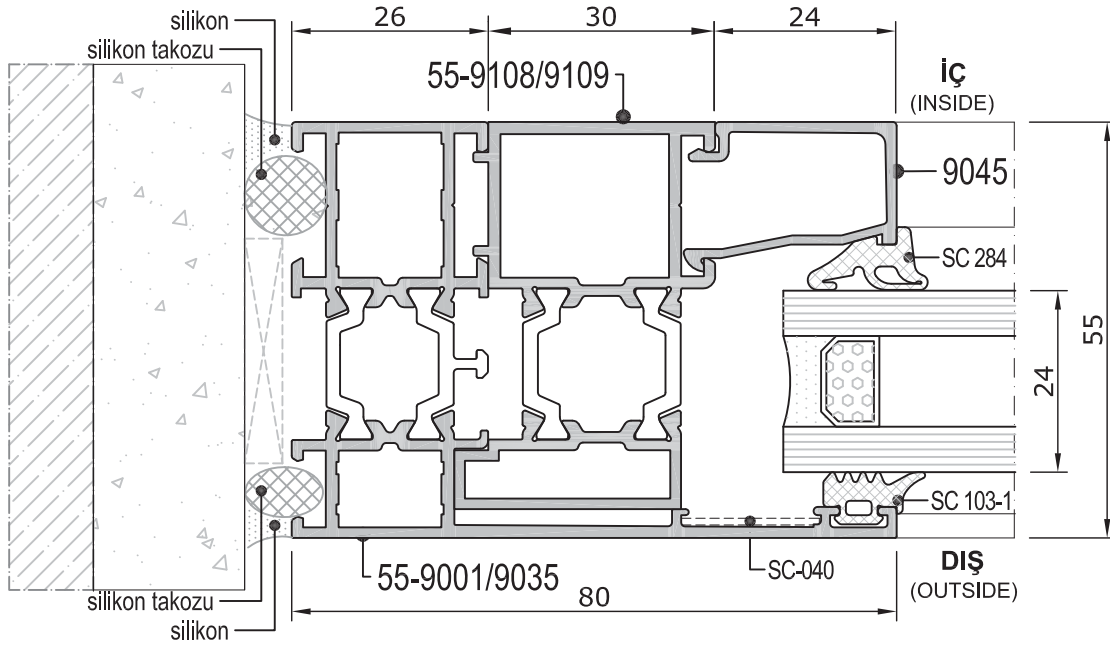
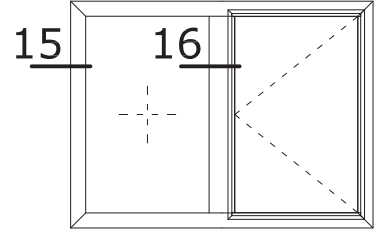

Detay
Detail 16

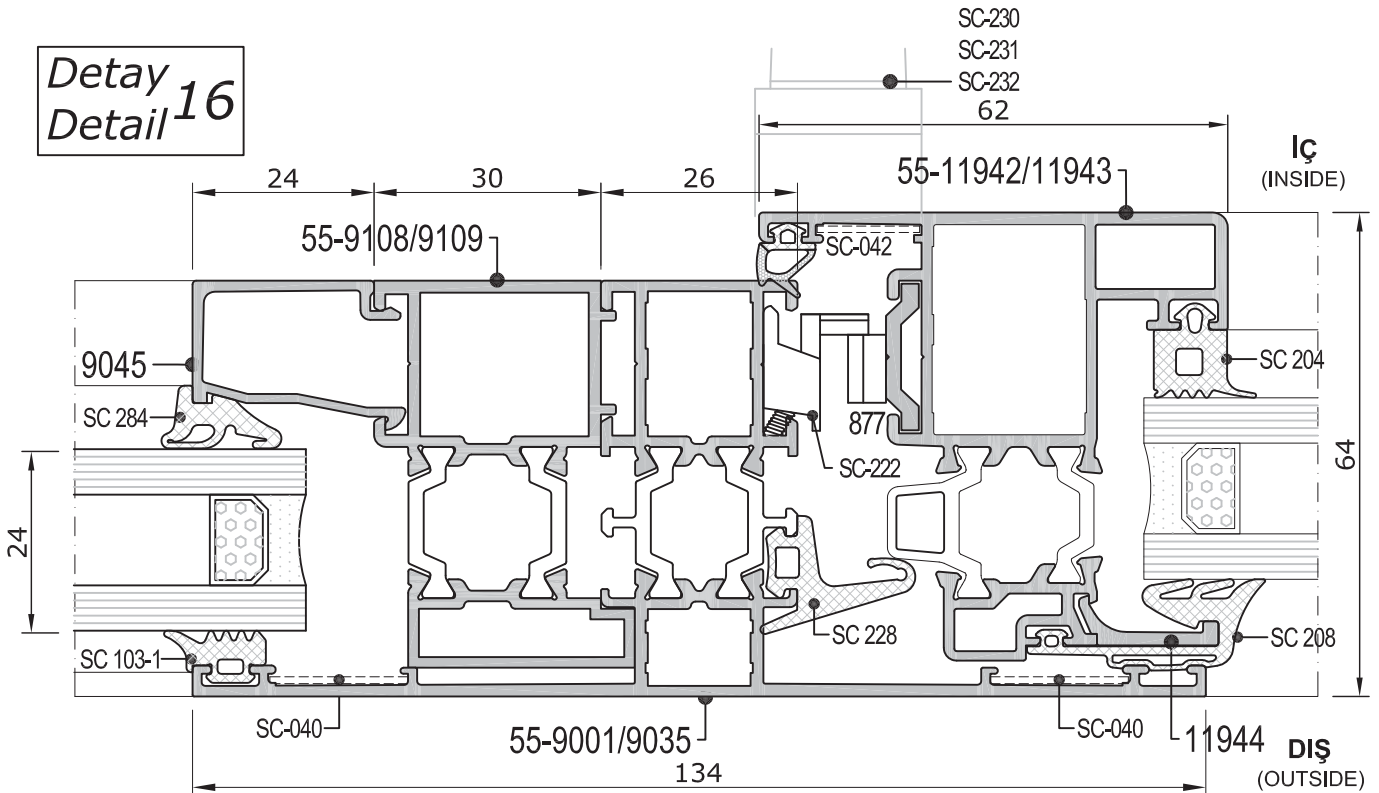

Typical System Detail
Prensip Sistem Detayları

Hidding Sash System Detail
Gizli Kanatlı Sistem Detayı

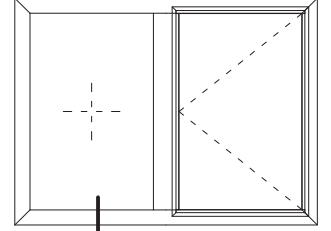

17

Detay
Detail¹⁷

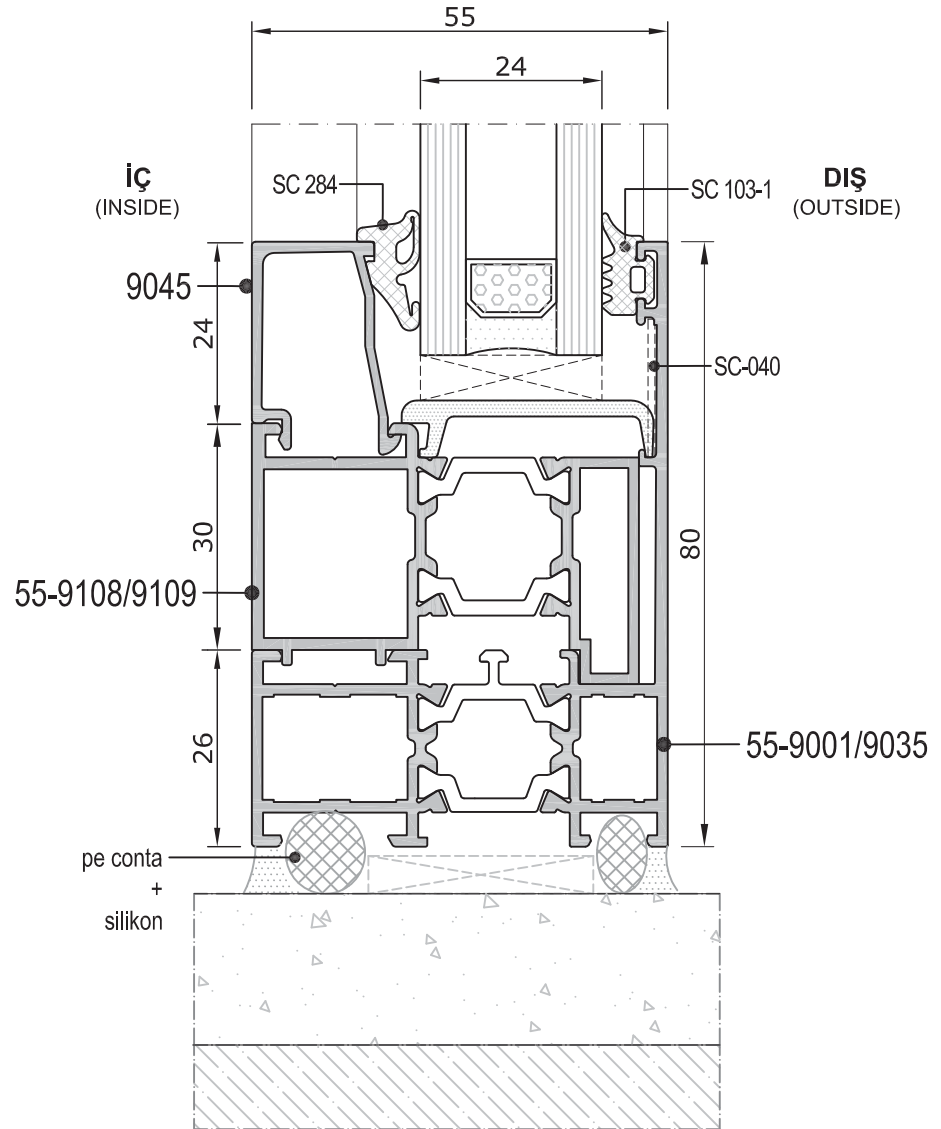

Typical System Detail
Prensip Sistem Detayları

Hidding Sash System Detail
Gizli Kanatlı Sistem Detayı

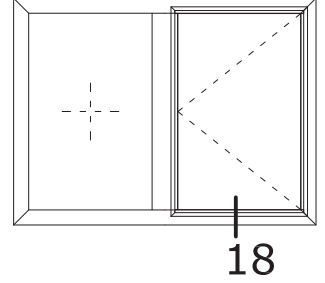

Detay
Detail 18

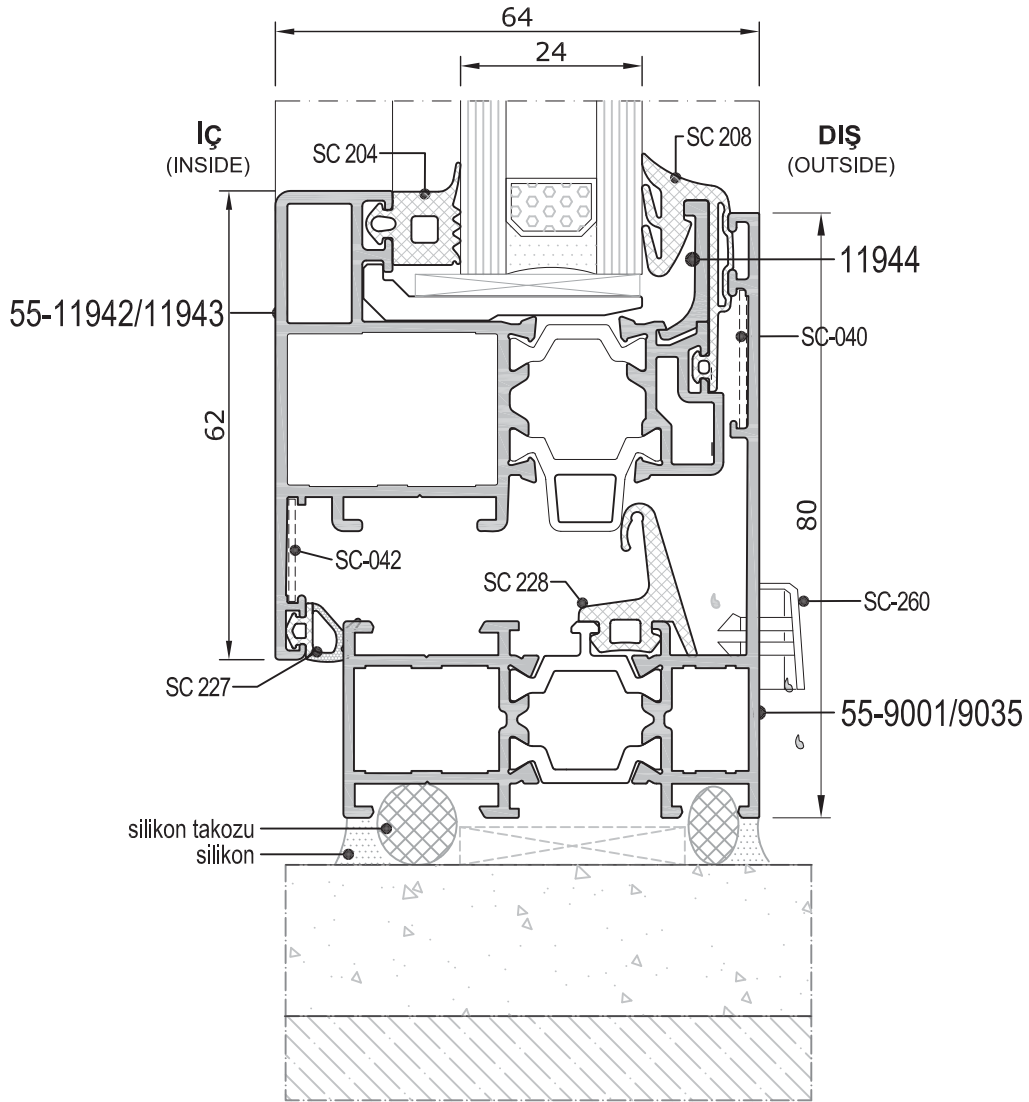

Typical System Detail
Prensip Sistem Detayları

Hidding Sash System Detail
Gizli Kanatlı Sistem Detayı

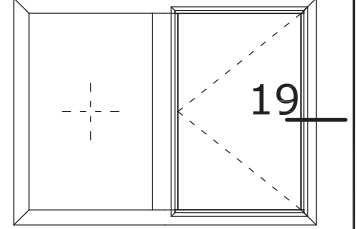

Detay
Detail 19

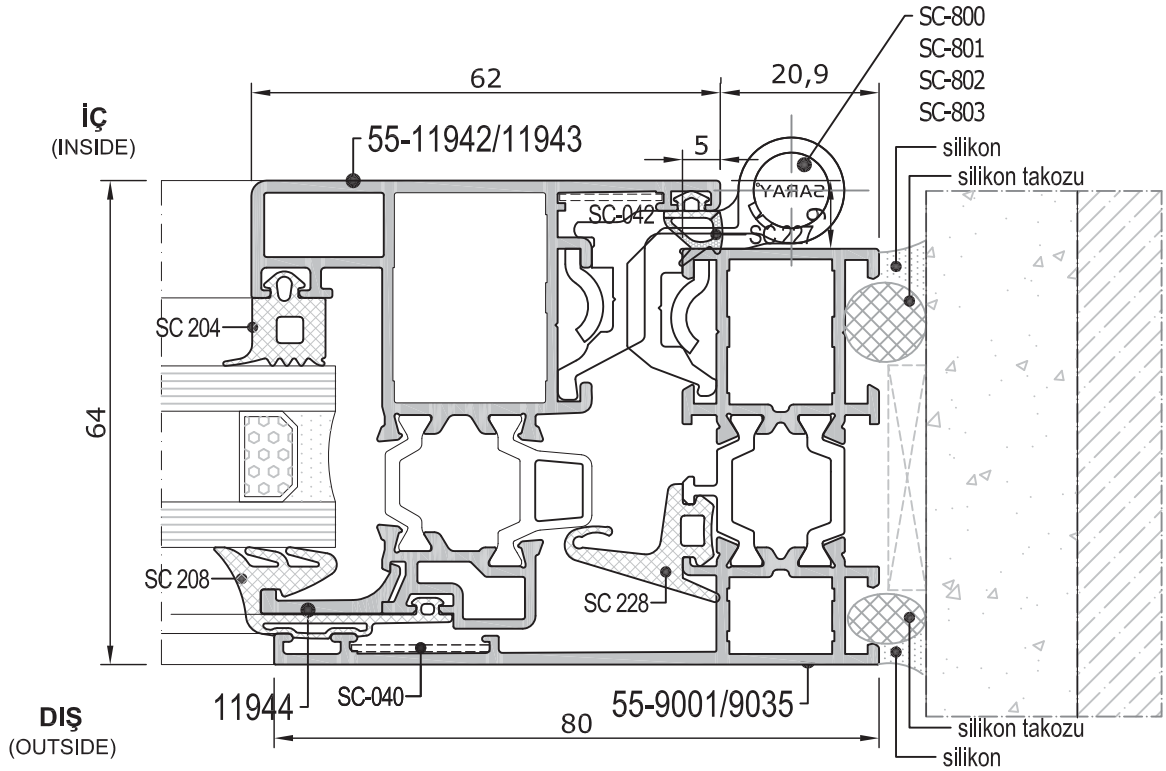

Typical System Detail
Prencip Sistem Detayları

Tilt&Slide
Parallel Lifting Sliding System Detail
Paralel Devirmeli Sürme Sistem Detayı

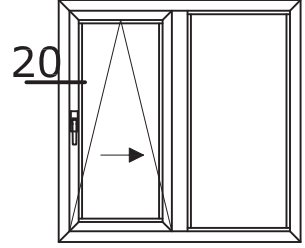

Detay
Detail 20

Çekme Sürme Aksesuar

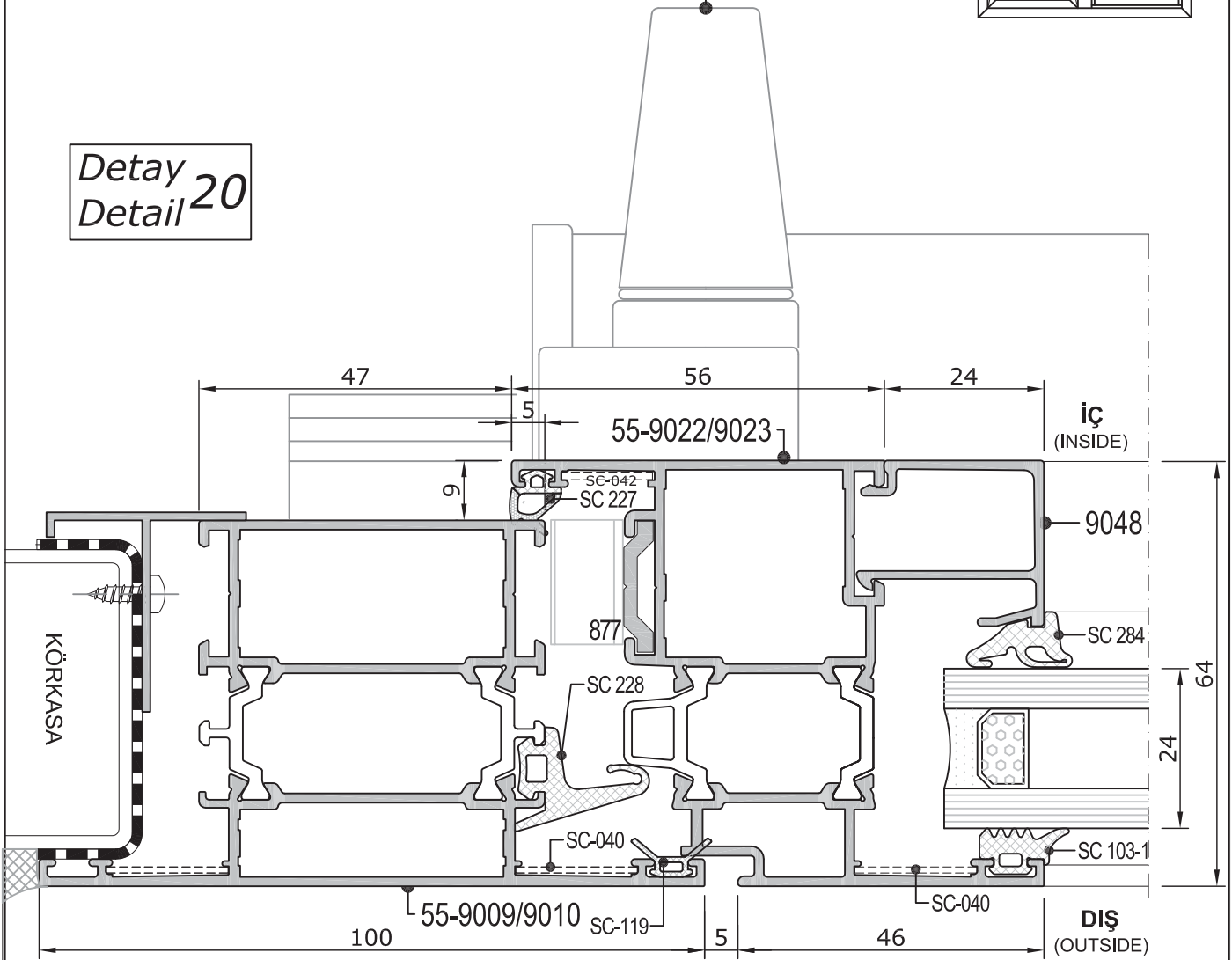

Typical System Detail
Prensip Sistem Detayları

Tilt&Slide

Parallel Lifting Sliding System Detail
Paralel Devirmeli Sürme Sistem Detayı

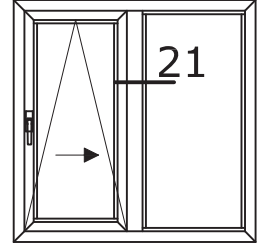

Detay
Detail 21

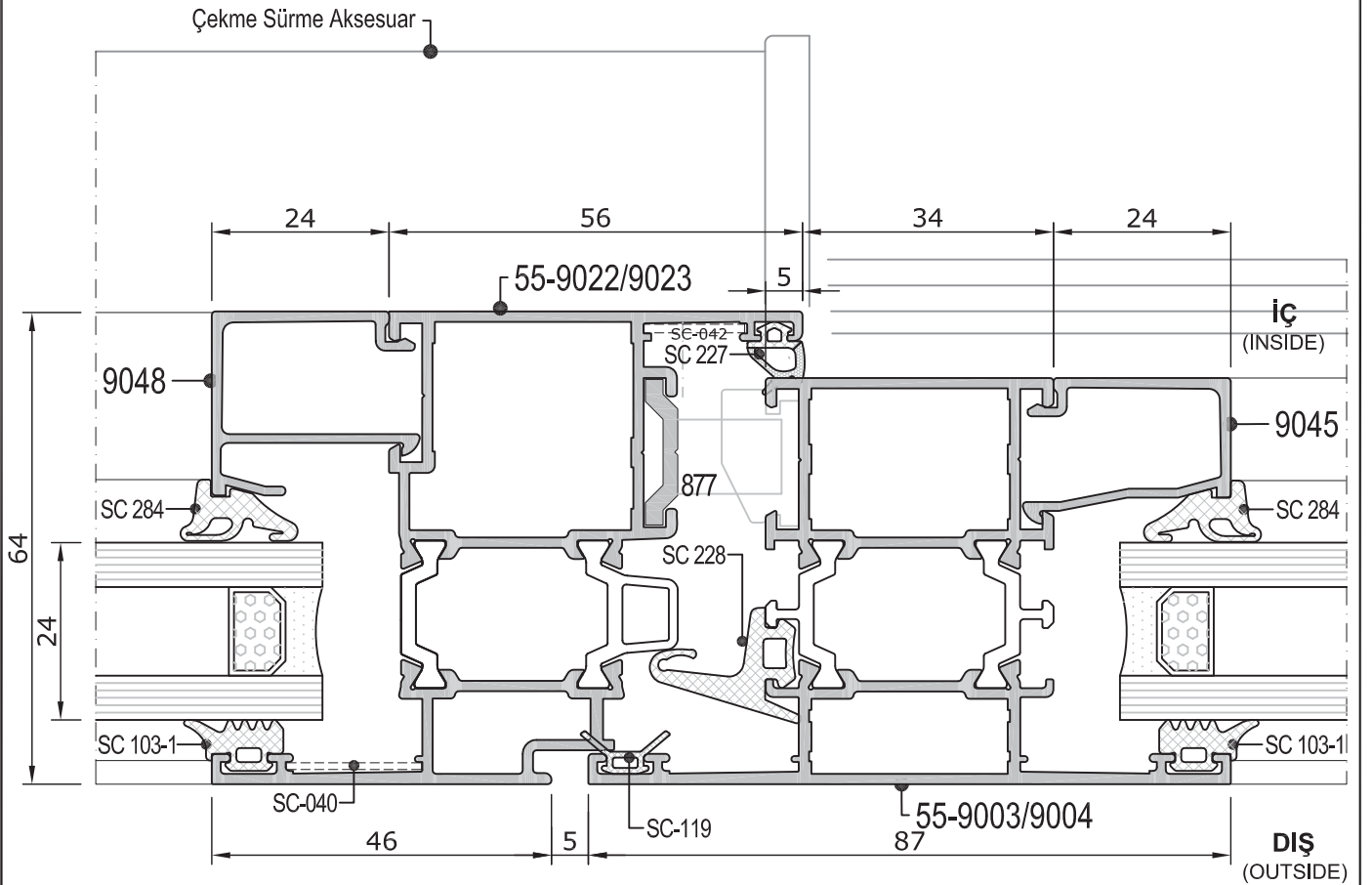

Typical System Detail
Prensip Sistem Detayları

Tilt&Slide
Parallel Lifting Sliding System Detail
Paralel Devirmeli Sürme Sistem Detayı

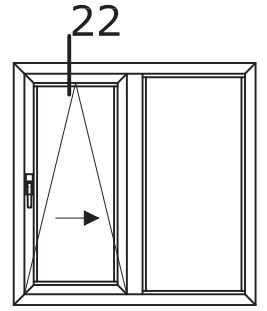

Detay
Detail 22

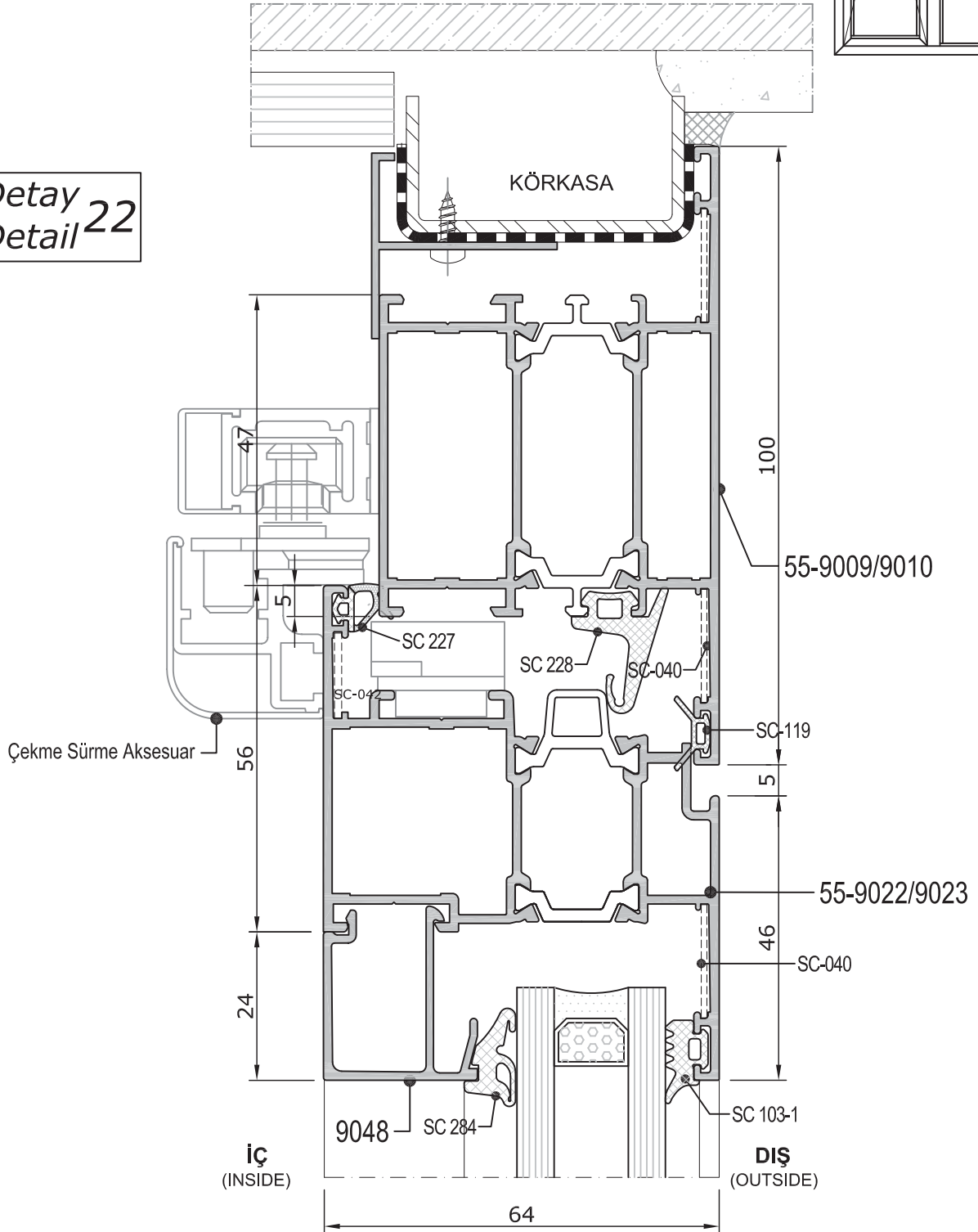

Typical System Detail
Prensip Sistem Detayları

F

Tilt/Slide
Parallel Lifting Sliding System Detail
Paralel Devirmeli Sürme Sistem Detayı

Detay
Detail 23

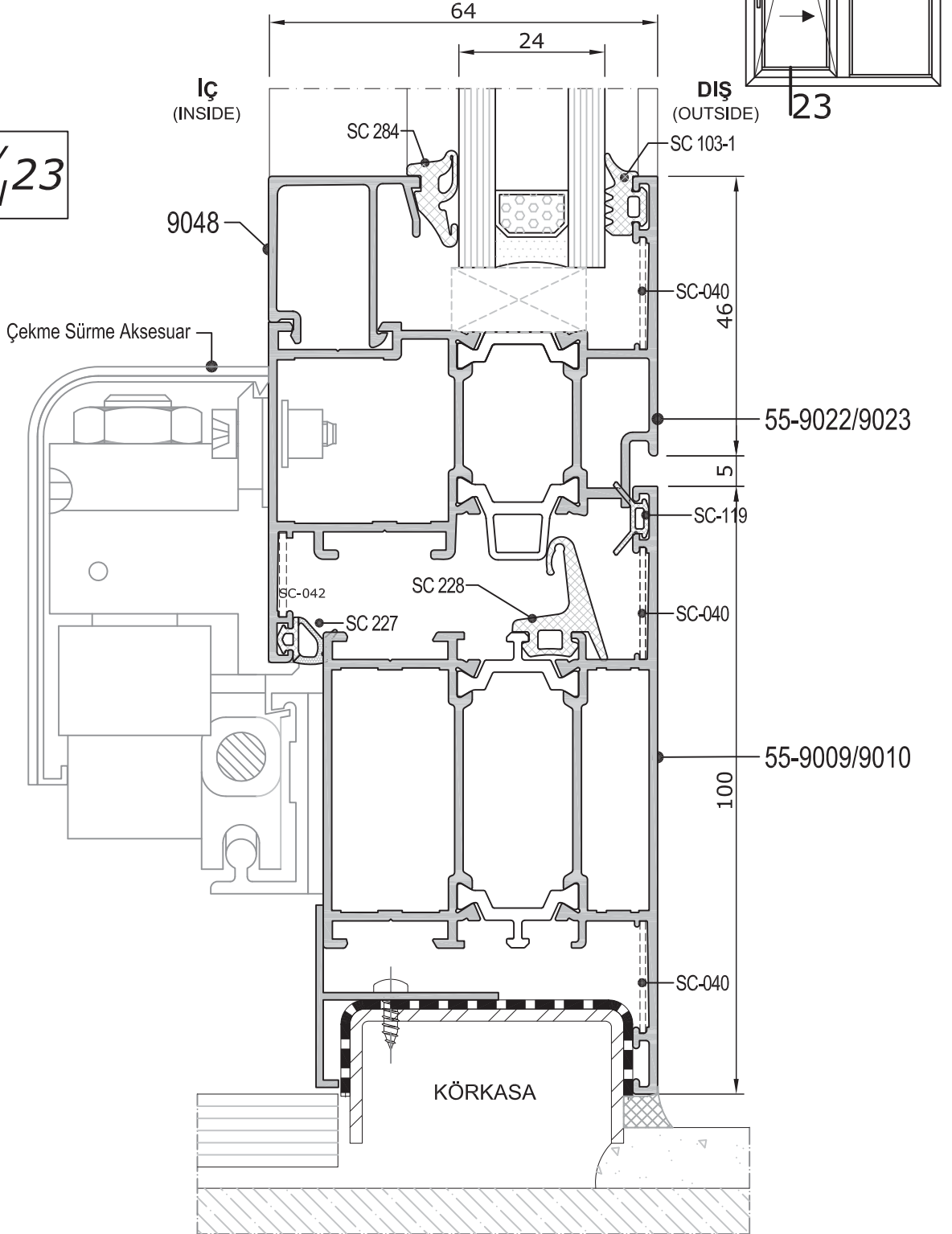

Typical System Detail
Prensip Sistem Detayları

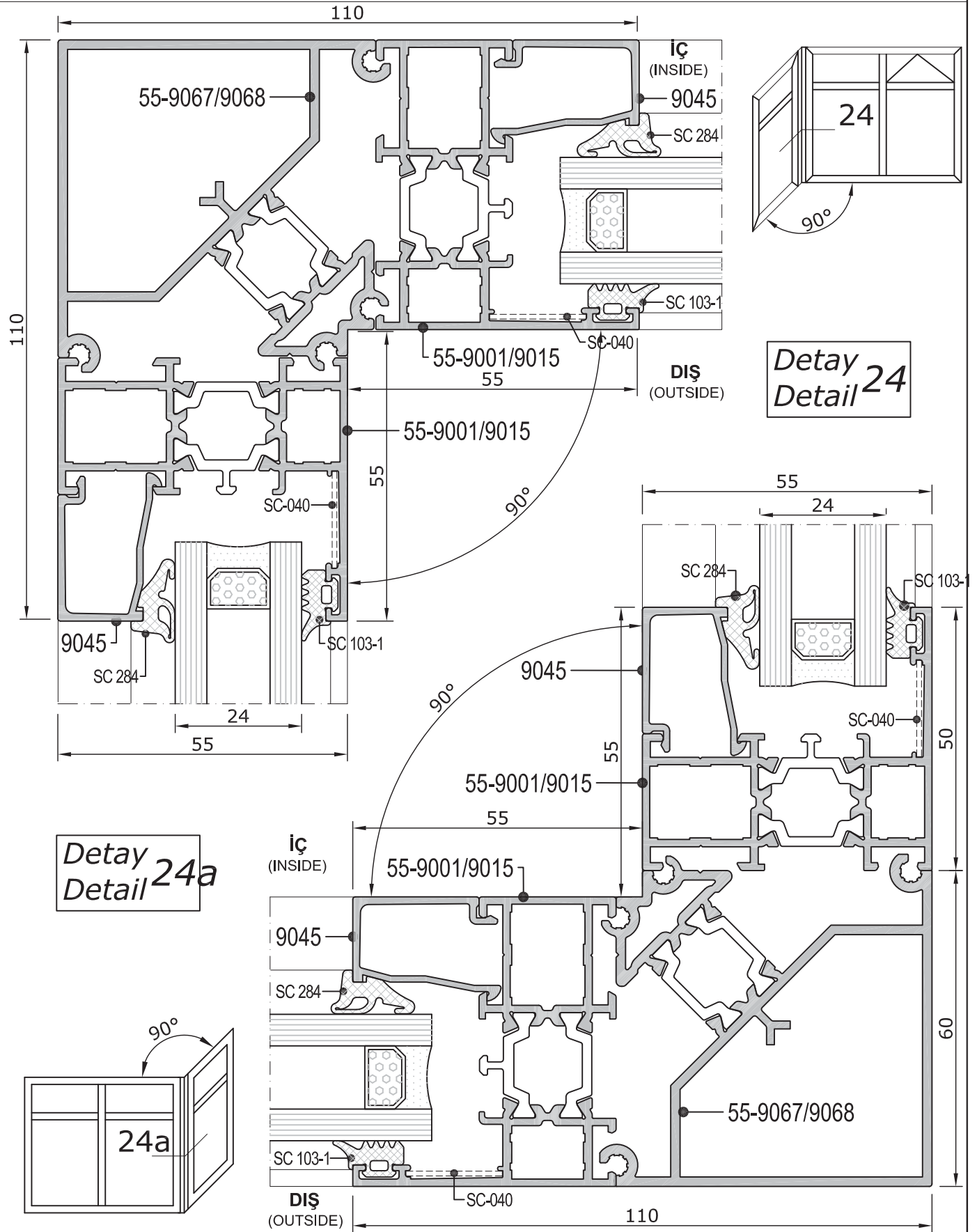

Typical System Detail
Prensip Sistem Detayları

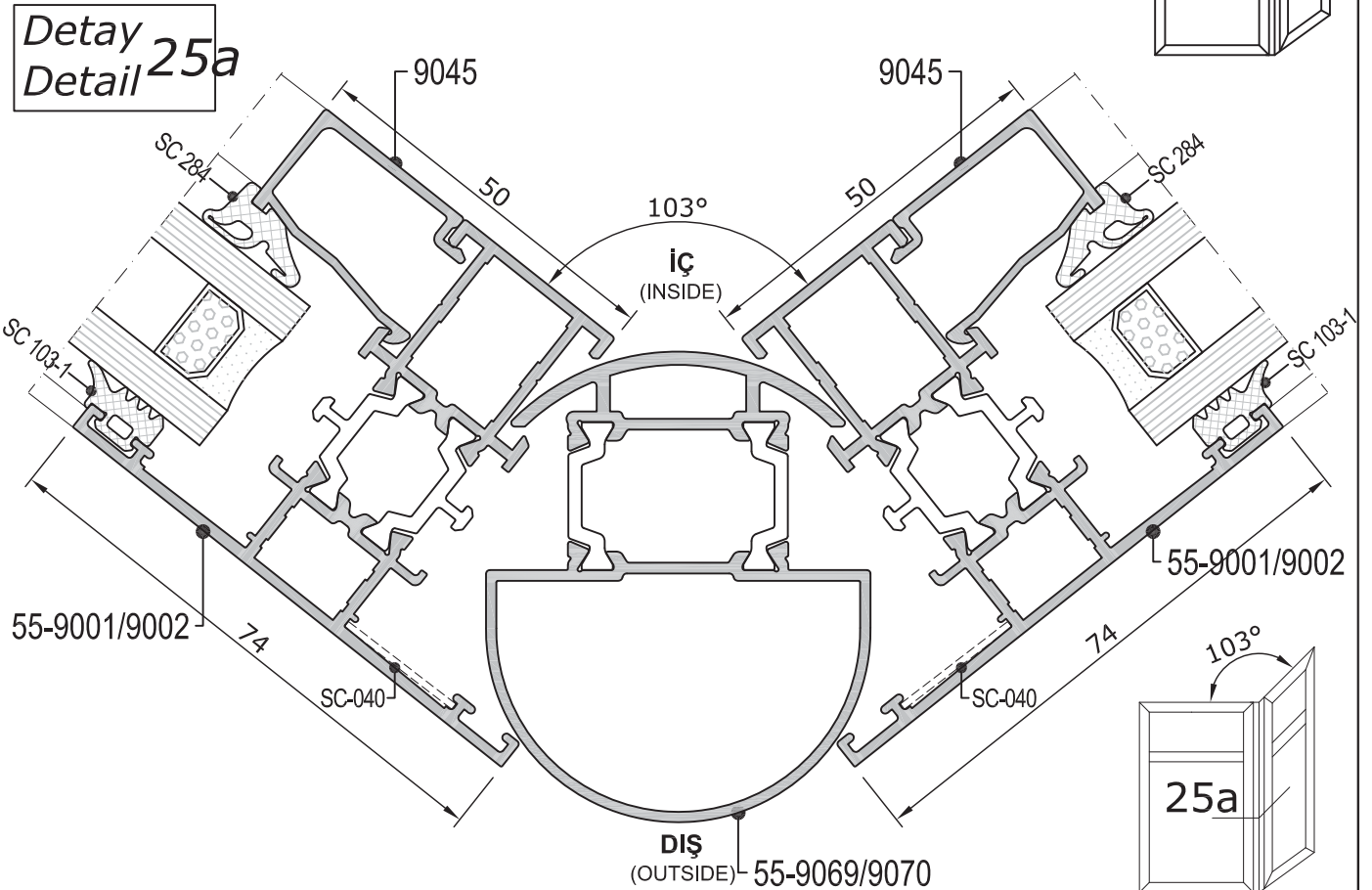
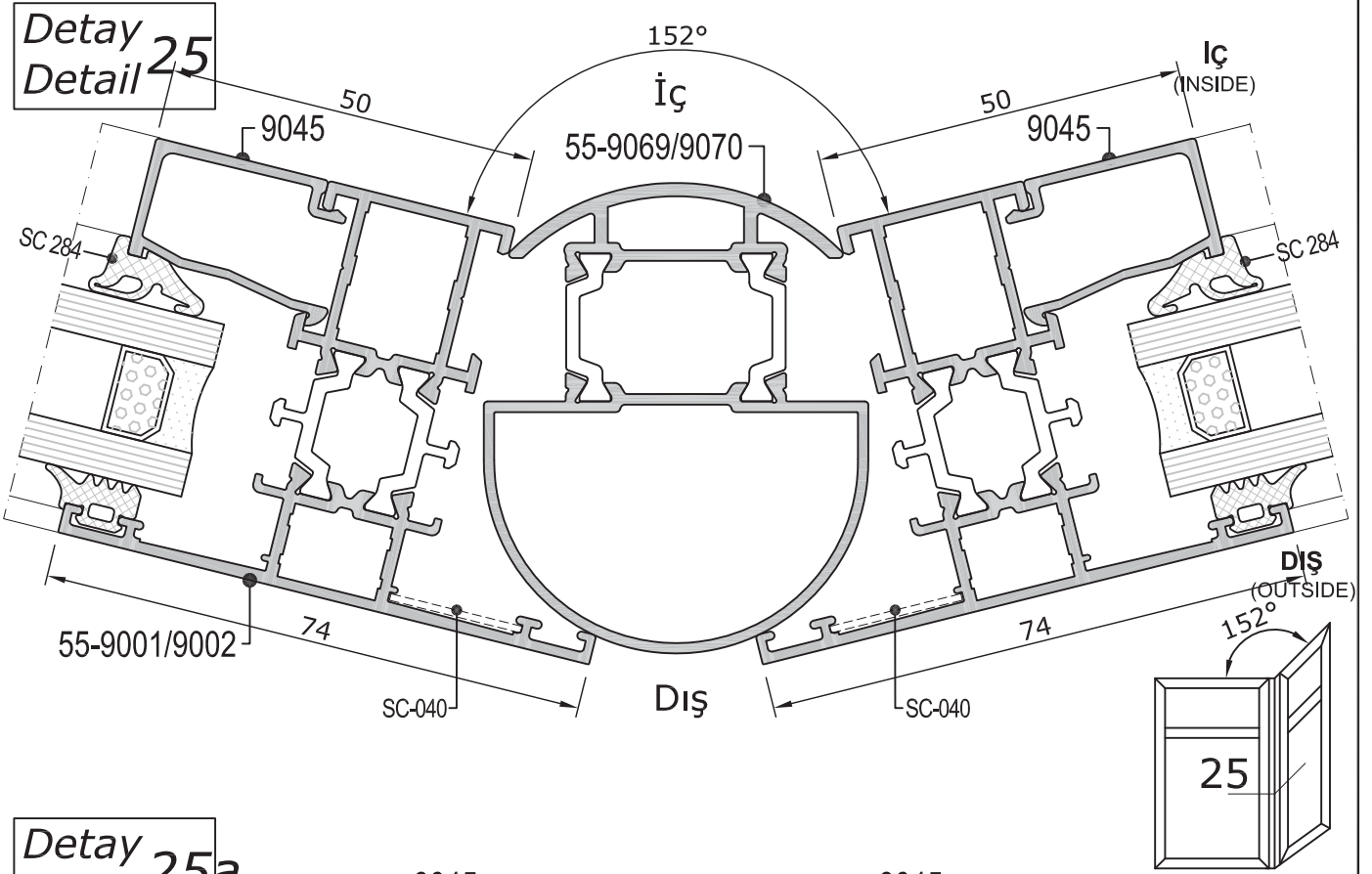

Typical System Detail
Prensip Sistem Detayları

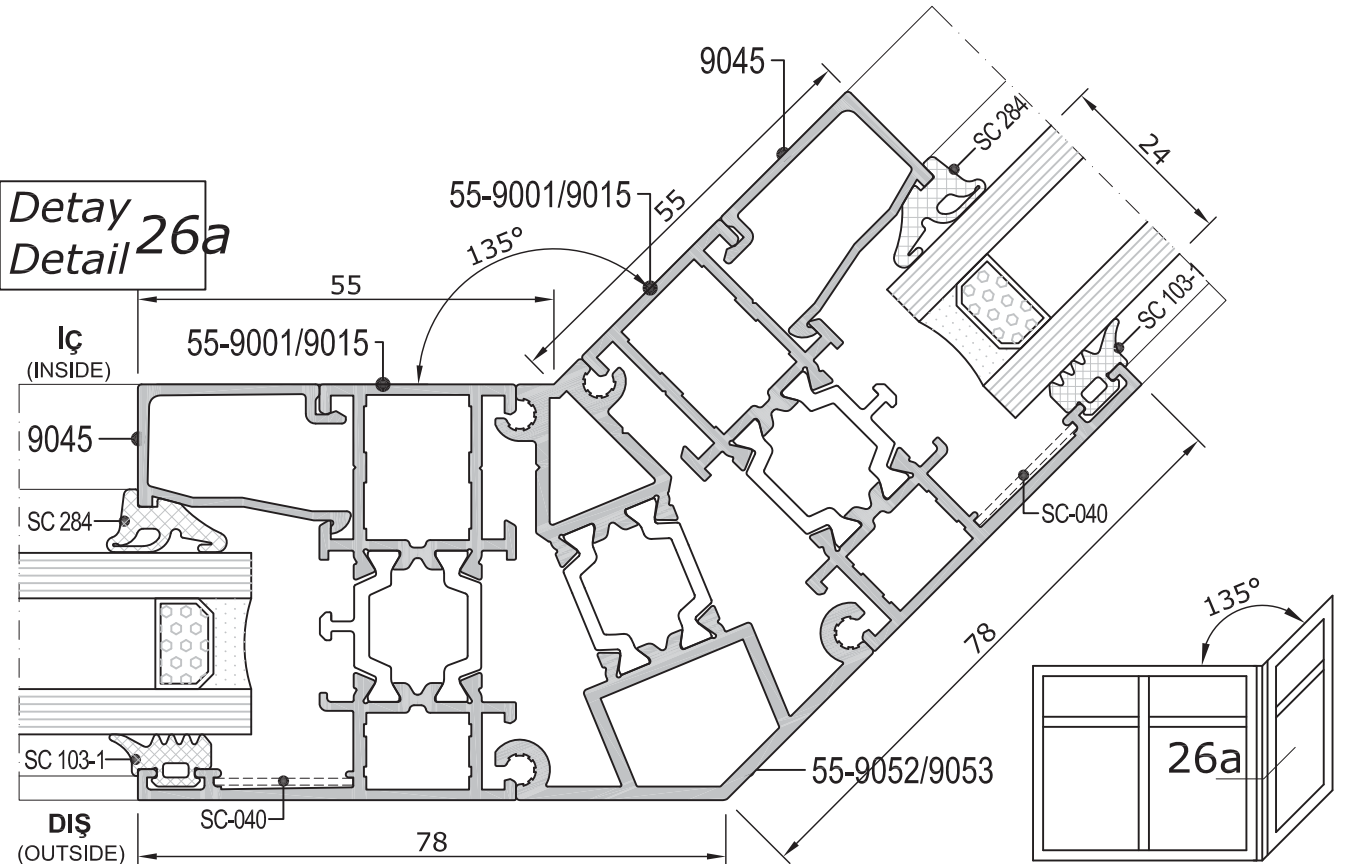
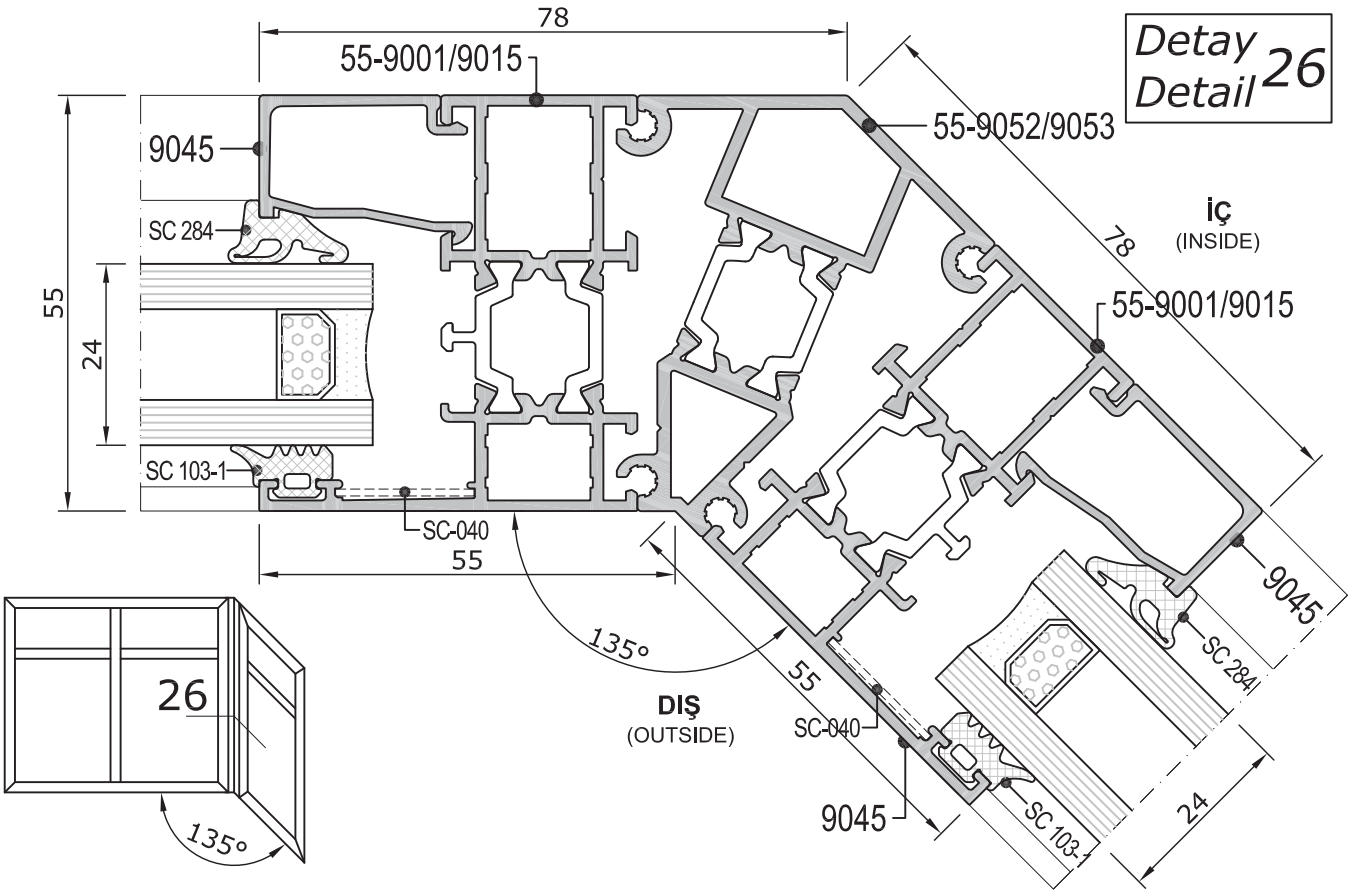

Typical System Detail
Prensip Sistem Detayları

16 mm Channel Sash System Detail
PVC Kanallı Kanat Sistem Detayı

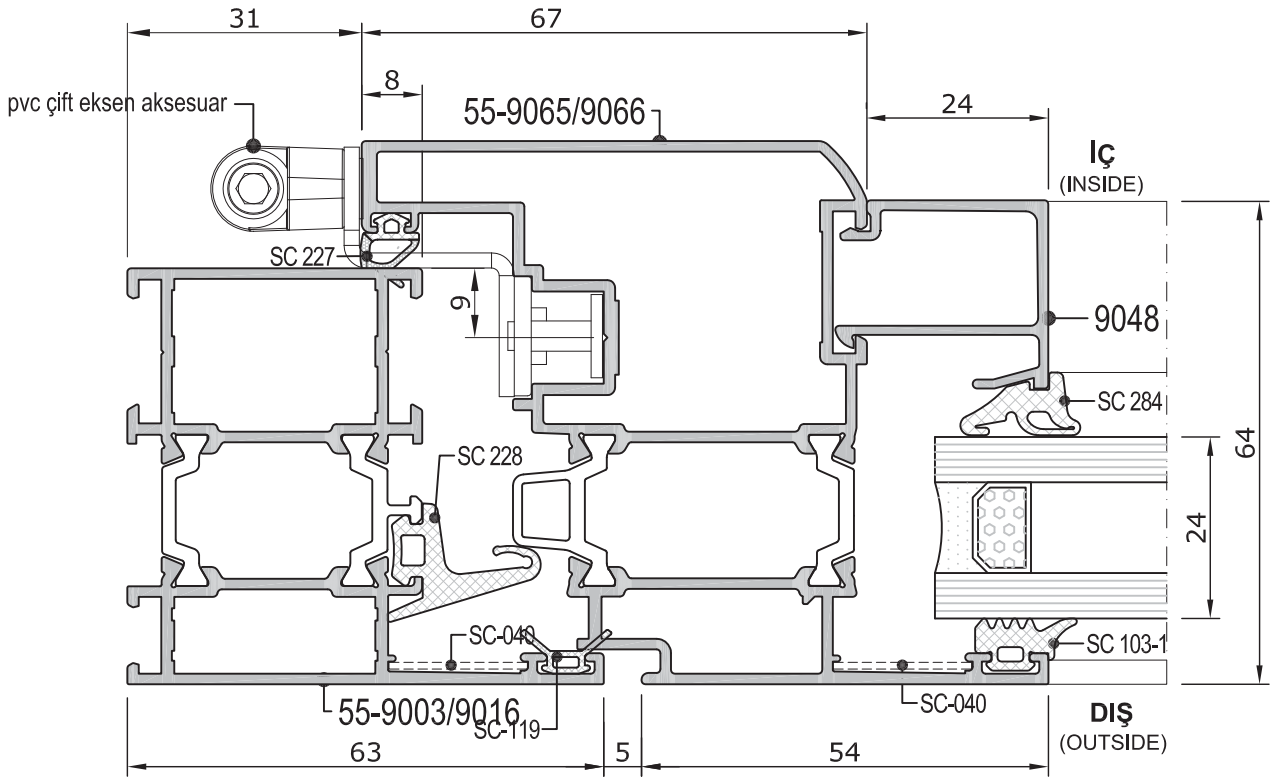
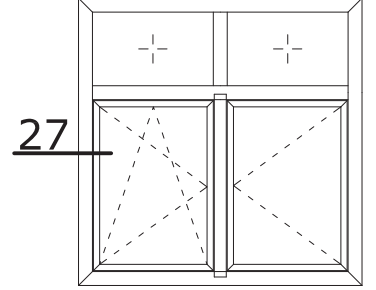

Detay
Detail 27

Typical System Detail
Prensip Sistem Detayları

16 mm Channel Sash System Detail
PVC Kanallı Kanat Sistem Detayı

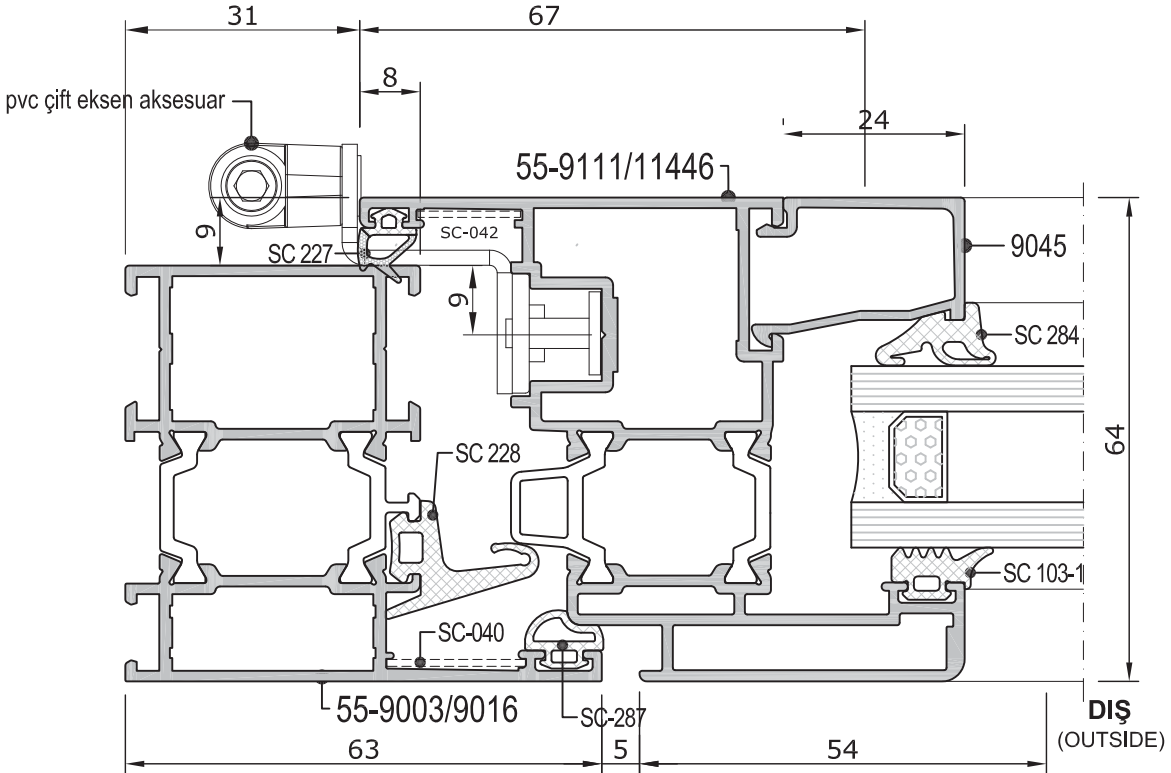
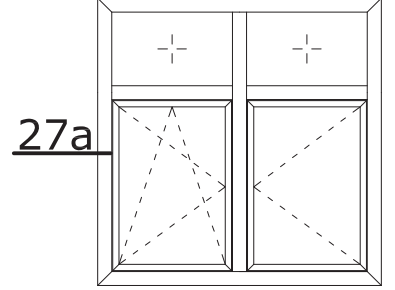

Detay
Detail 27a

Typical System Detail
Prensip Sistem Detayları

16 mm Channel Sash System Detail
PVC Kanallı Kanat Sistem Detayı

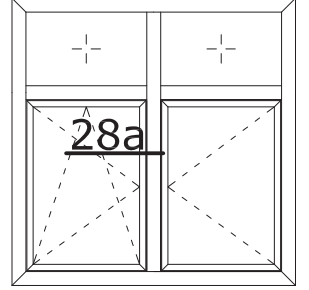

Detay
Detail **28a**

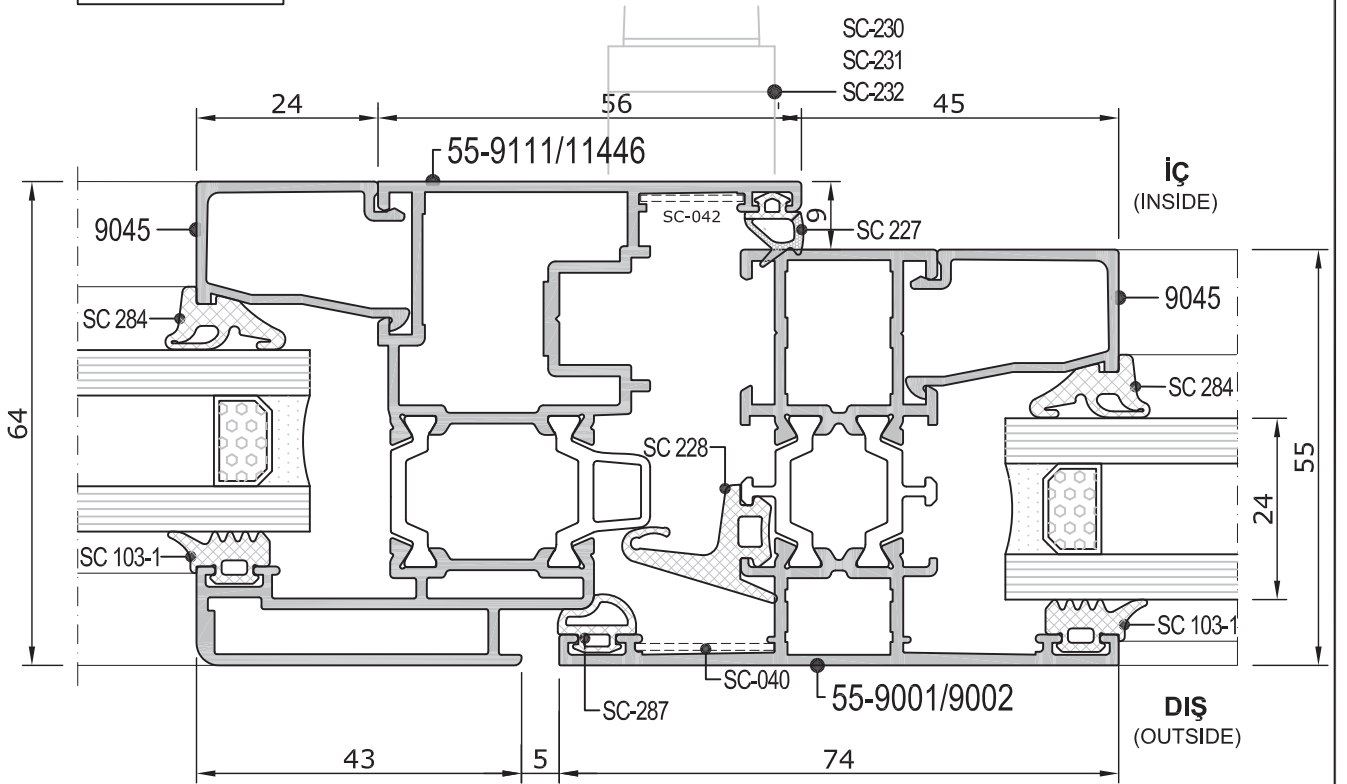

Typical System Detail
Prensip Sistem Detayları

Pivot Window System Detail
Pivot Pencere Sistem Detayı

Detay
Detail **29**

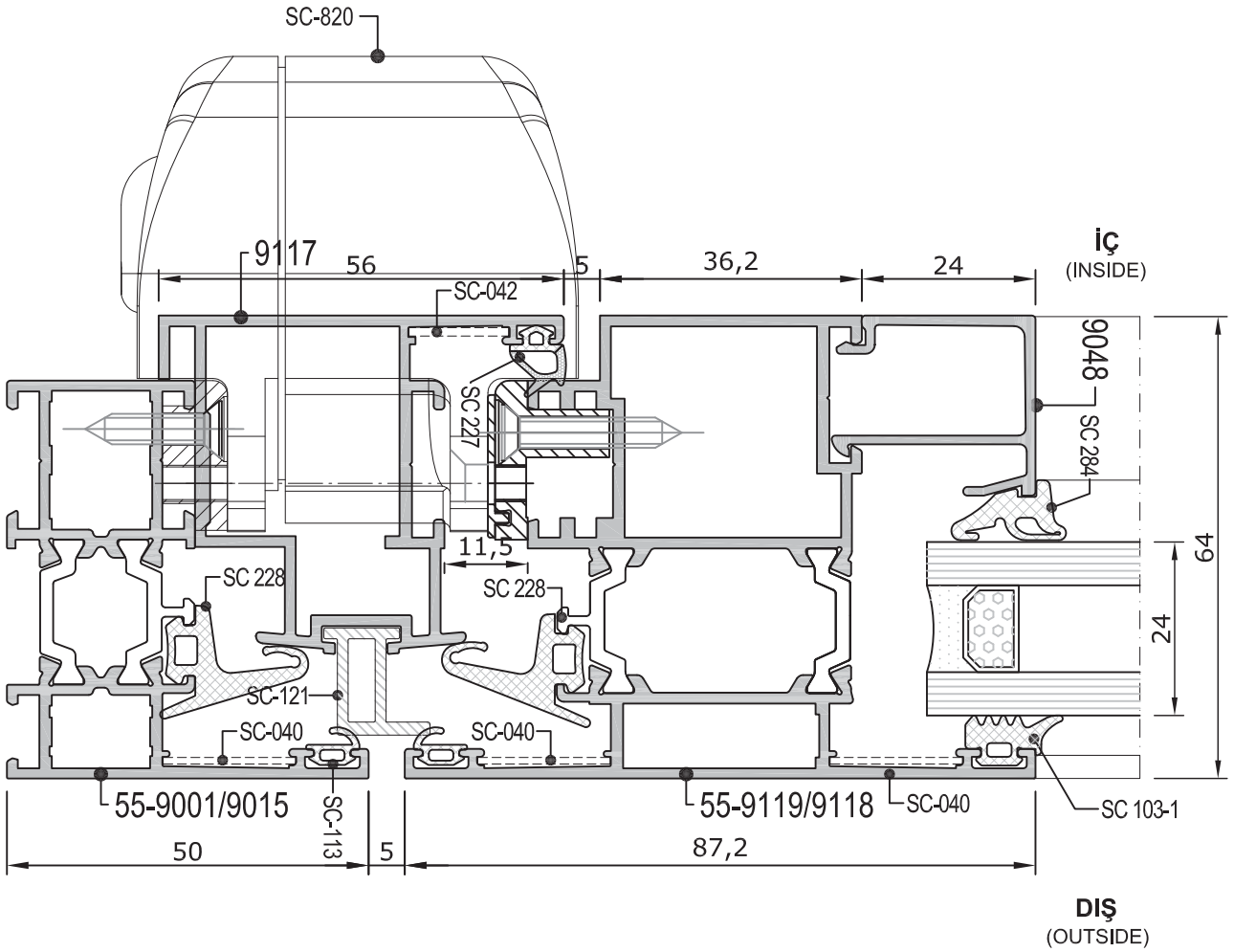
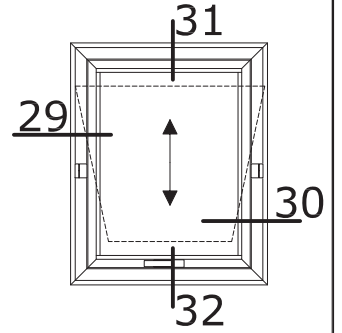

Typical System Detail
Prensip Sistem Detayları

Pivot Window System Detail
Pivot Pencere Sistem Detayı

Detay
Detail 30

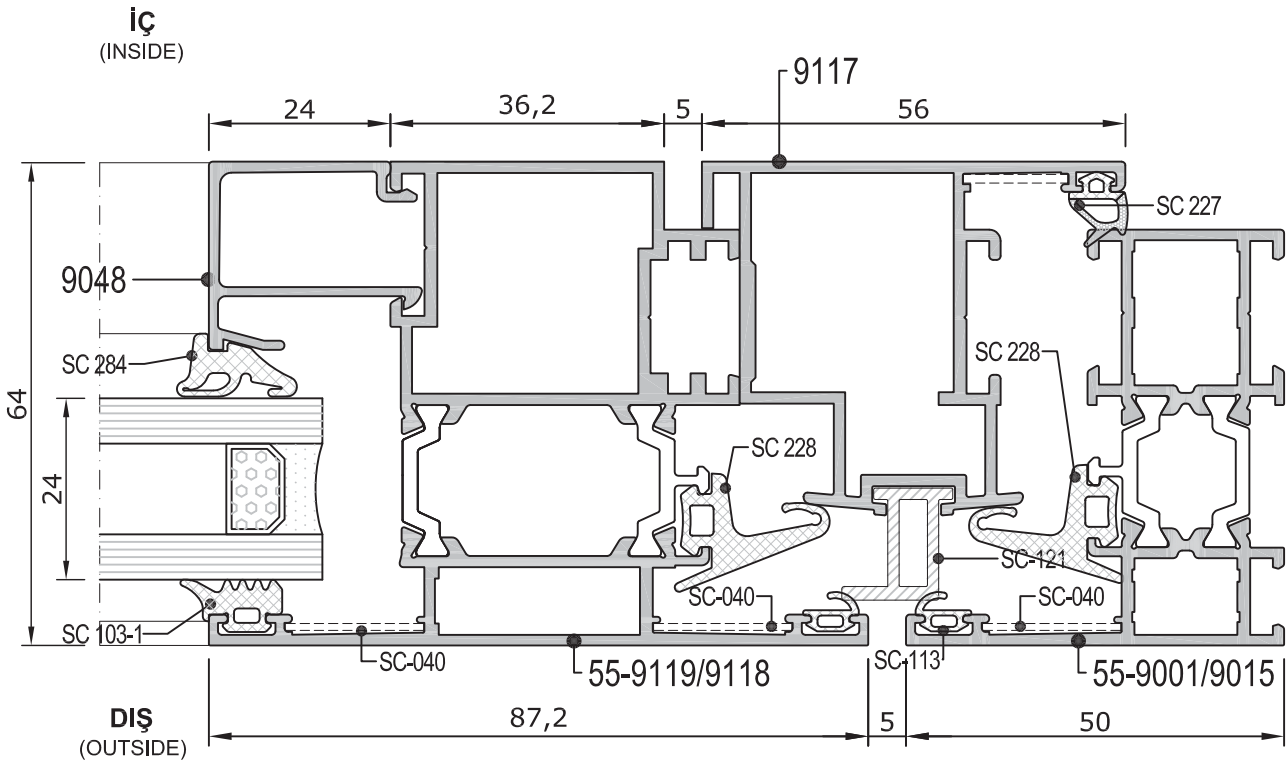
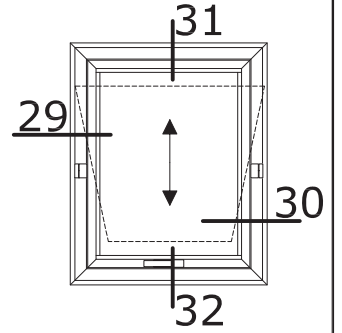

Typical System Detail
Prensip Sistem Detayları

Pivot Window System Detail
Pivot Pencere Sistem Detayı

Detay
Detail **31**

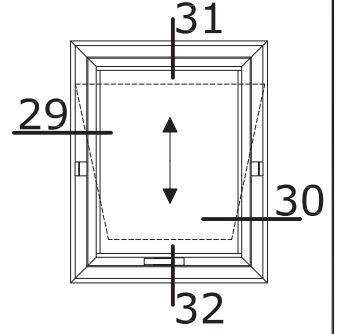
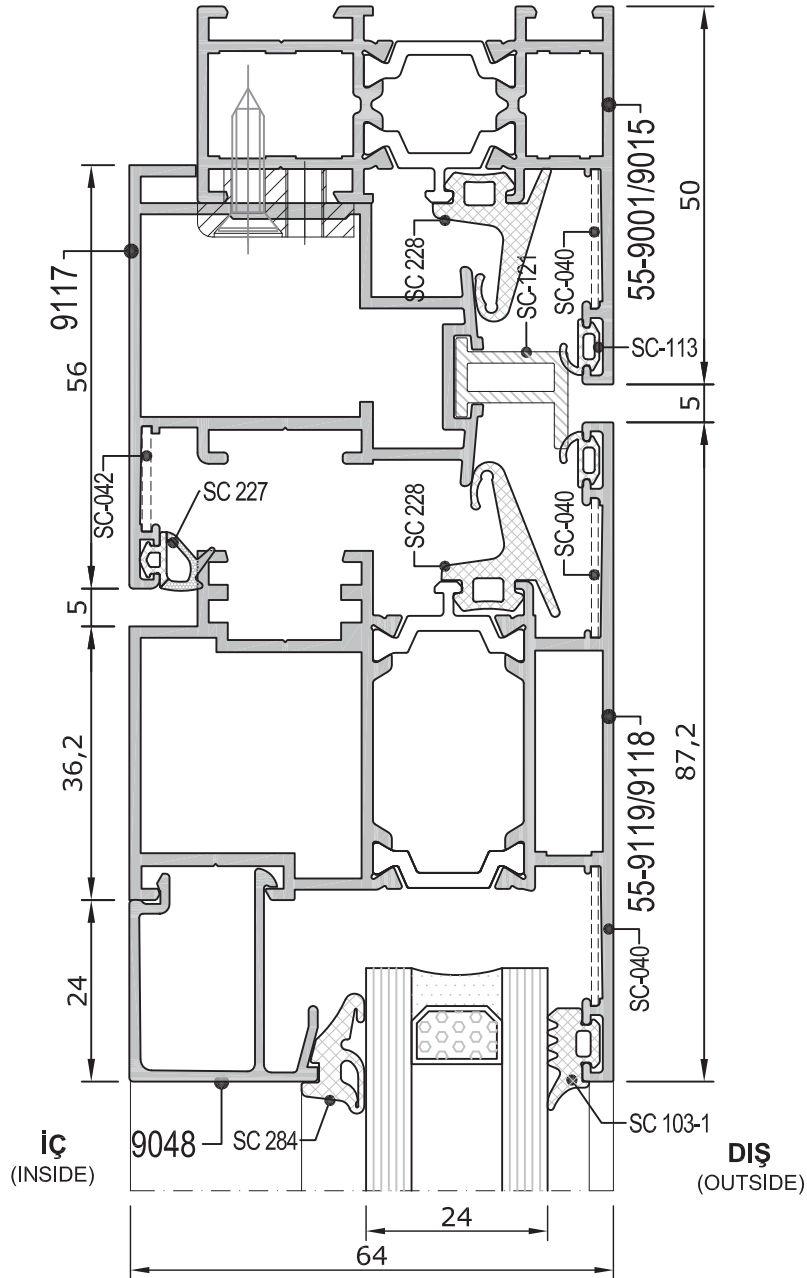

NOT: SC-121 PVC PARÇANIN YÖNÜ DETAYLARDAKİ GİBİ MONTAJ YAPILMADIR.

Typical System Detail
Prensip Sistem Detayları

Pivot Window System Detail
Pivot Pencere Sistem Detayı

Detay
Detail **32**

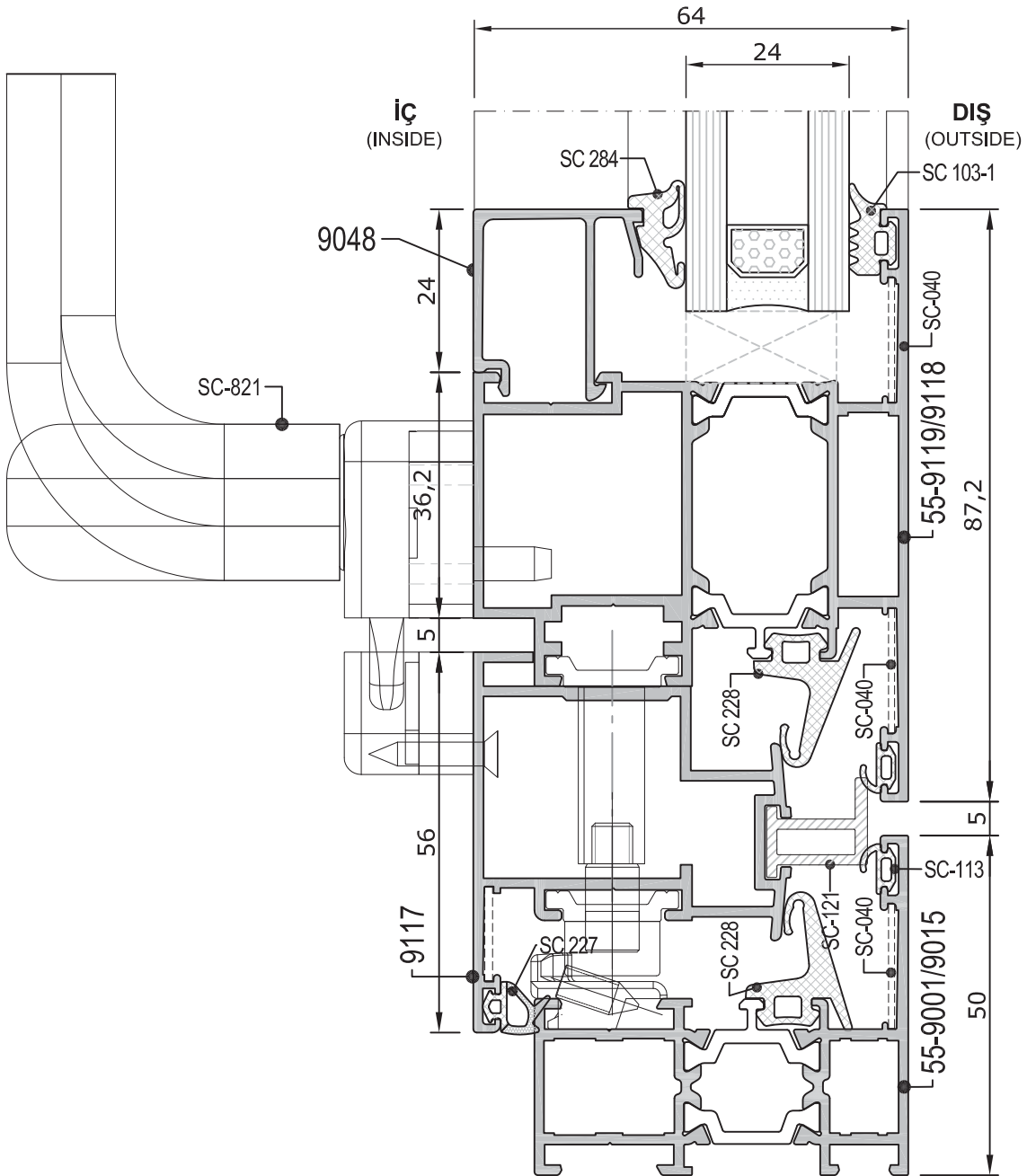
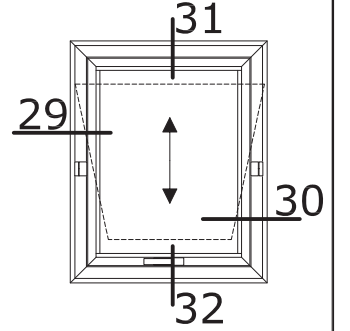

NOT: SC-121 PVC PARÇANIN YÖNÜ DETAYLARDAKİ GİBİ MONTAJ YAPILMADIR.

Typical System Detail Prensip Sistem Detayları

Folding Sliding System Detail Katlanır Kapı Sistem Detayı

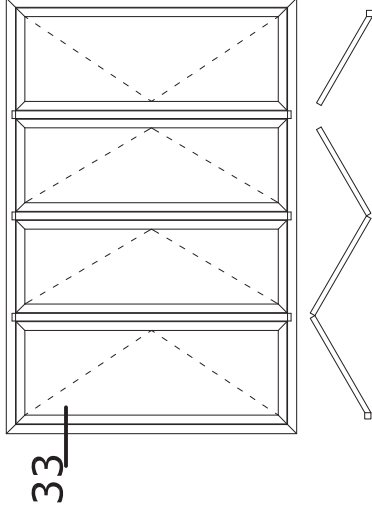

Detay 33
Detail

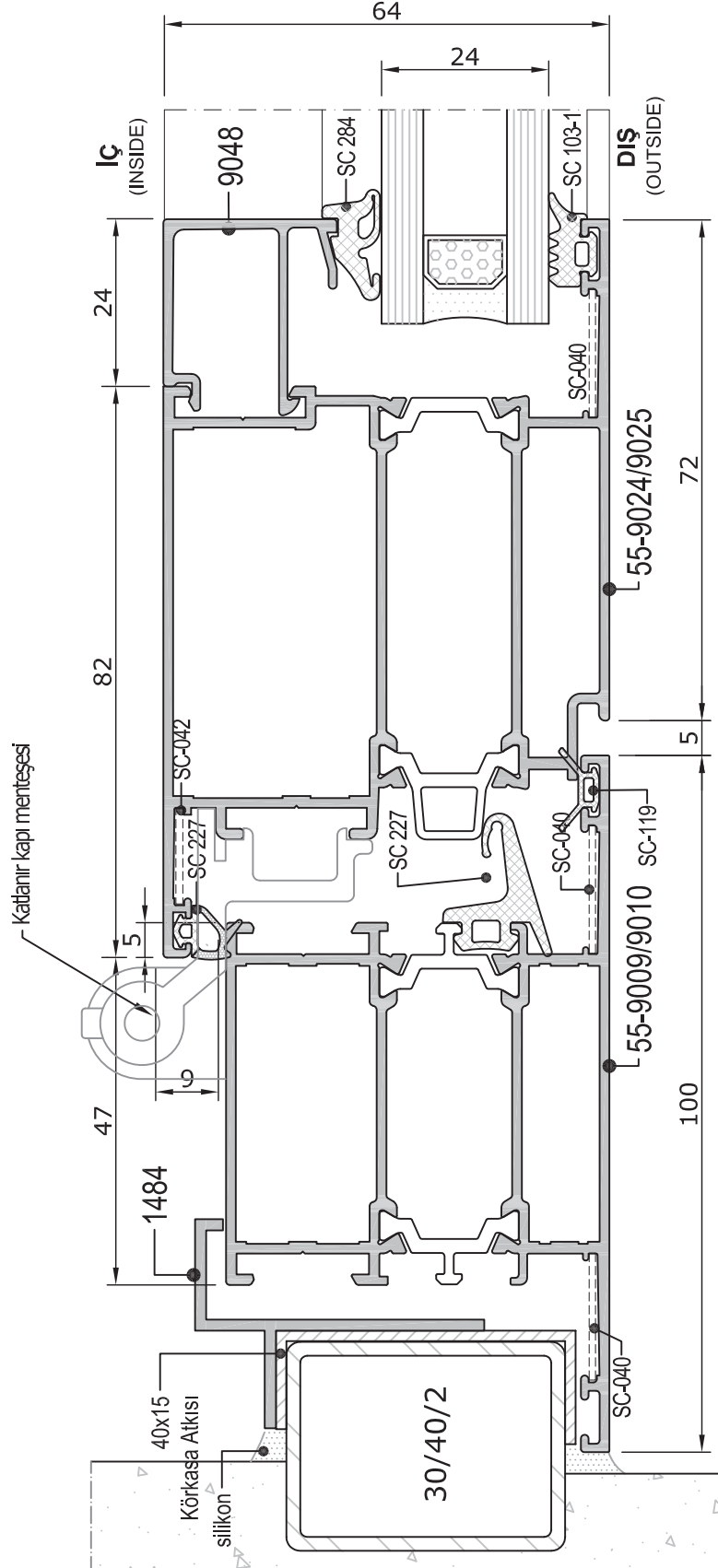

Typical System Detail Prensip Sistem Detayları

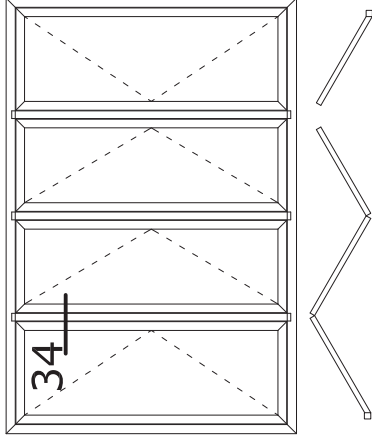

Folding Sliding System Detail Katlanır Kapı Sistem Detayı

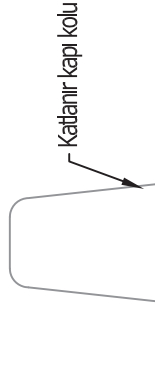

Detay 34
Detail

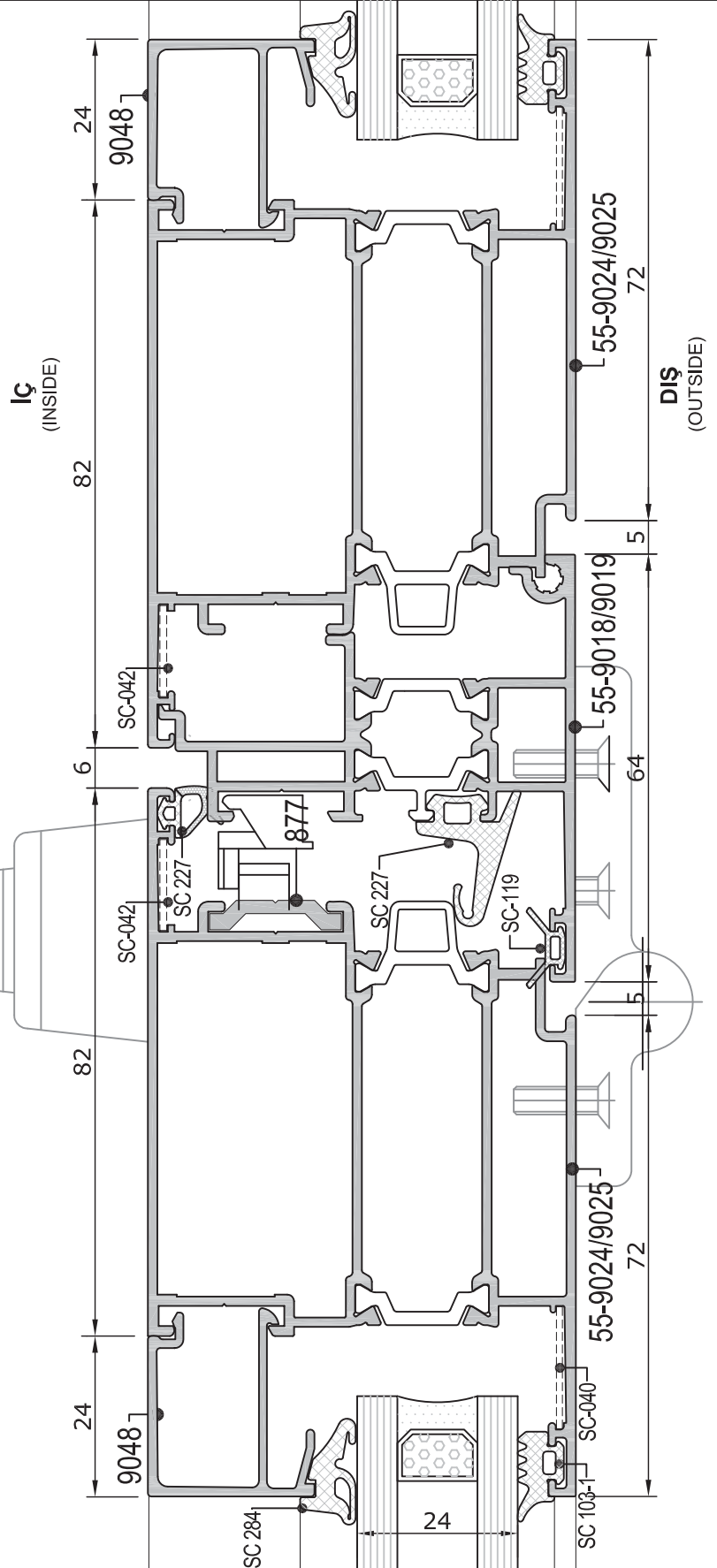

Typical System Detail Prensip Sistem Detayları

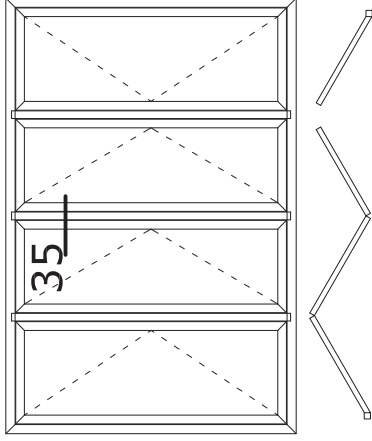

Folding Sliding System Detail Katlanır Kapı Sistem Detayı

Katlanır kapı menteşesi

Detay 35
Detail

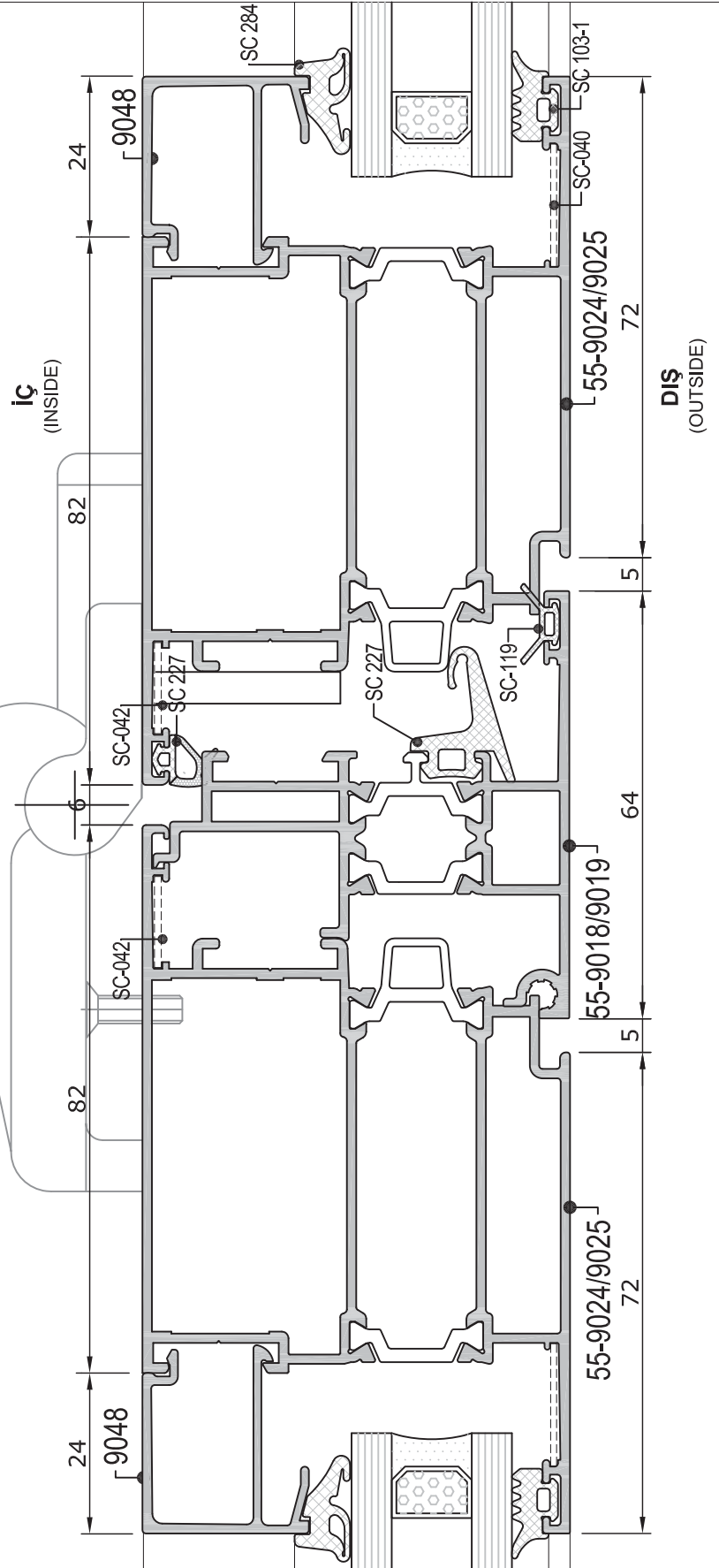

Typical System Detail Prensip Sistem Detayları

Folding Sliding System Detail Katlanır Kapı Sistem Detayı

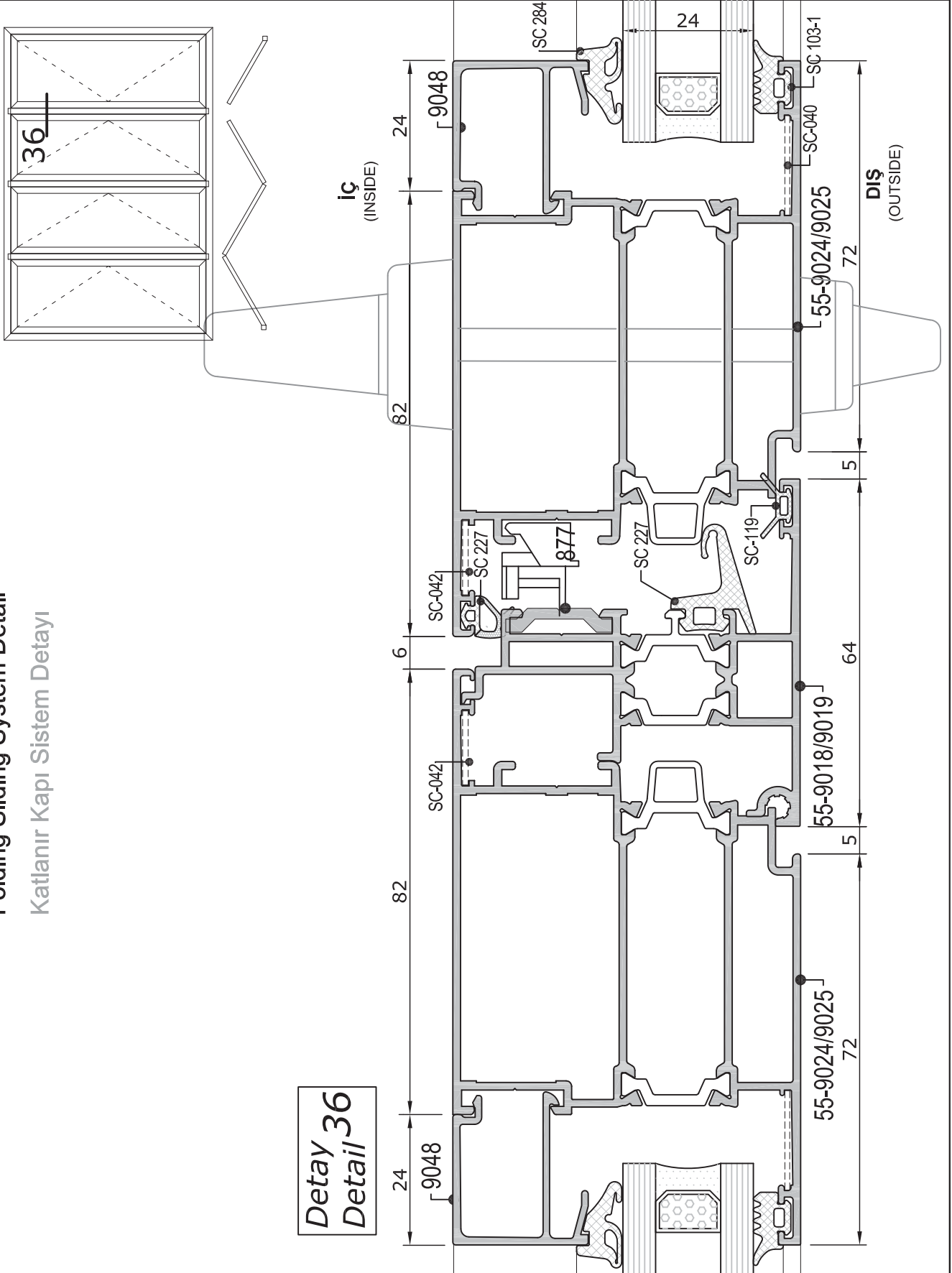

Typical System Detail Prensip Sistem Detayları

Folding Sliding System Detail Katlanır Kapı Sistem Detayı

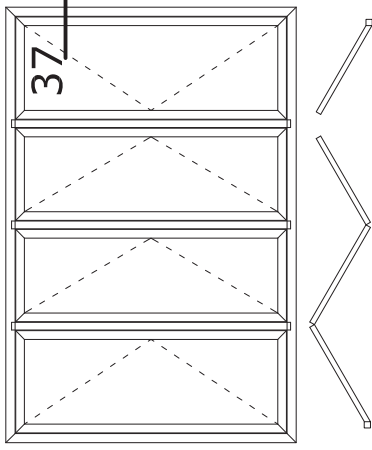

Detay 37
Detail

İÇ
(INSIDE)

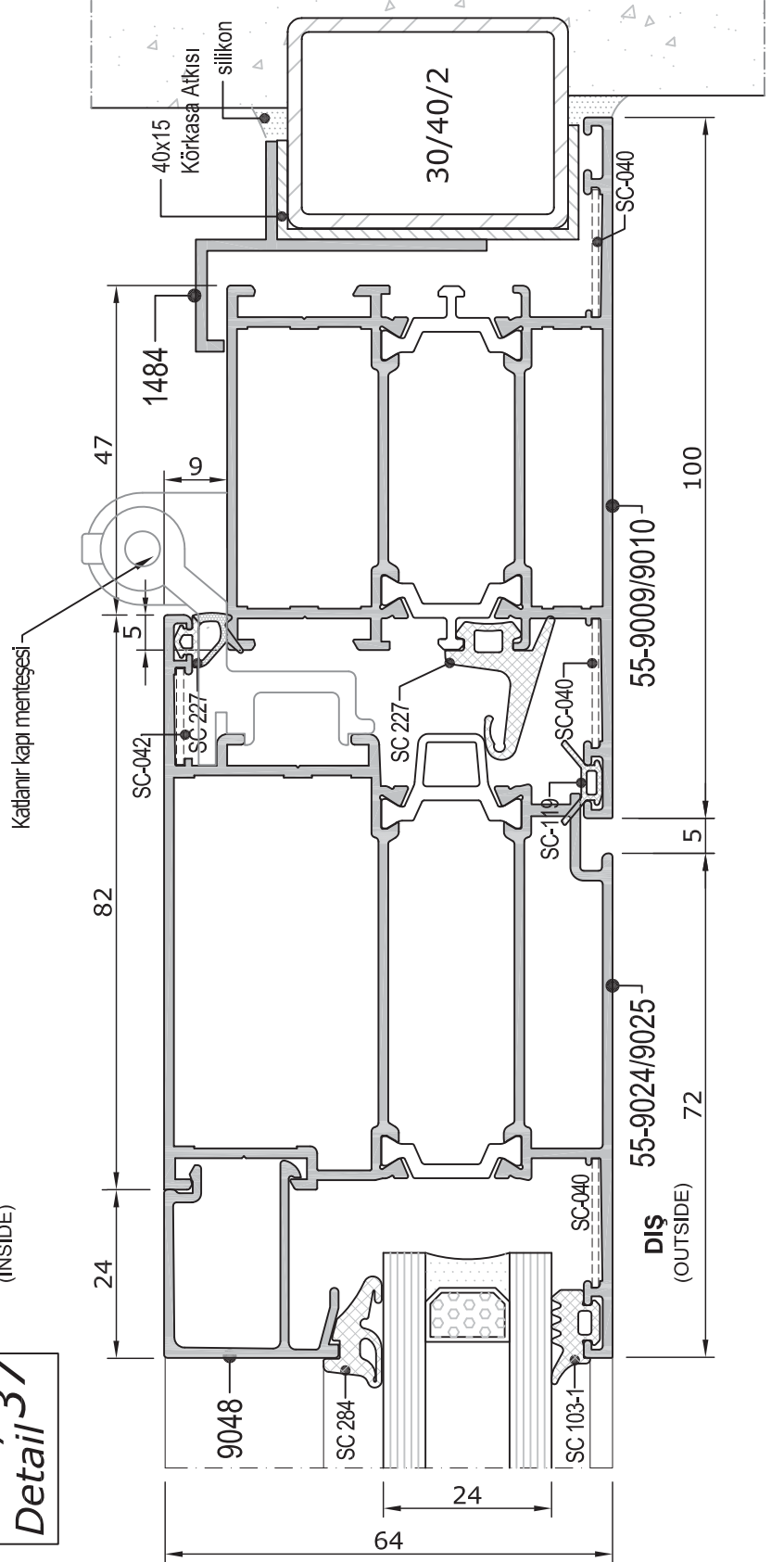

Typical System Detail
Prensip Sistem Detayları

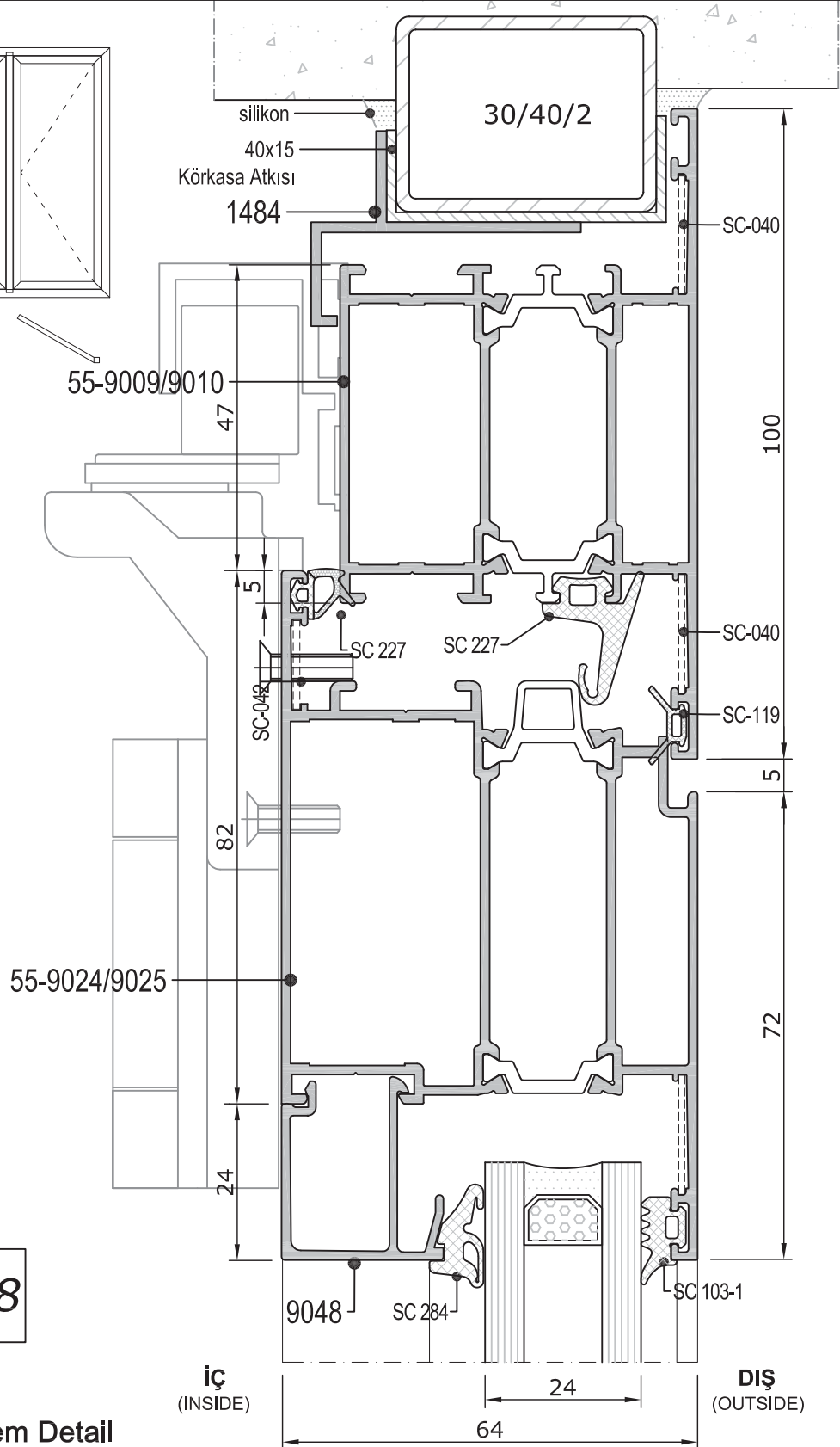
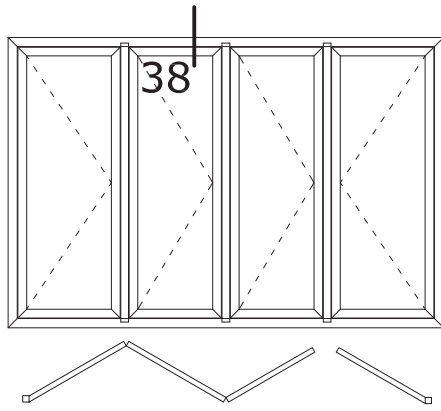

Detay
Detail 38

Folding Sliding System Detail
Katlanır Kapı Sistem Detayı

Typical System Detail
Prensip Sistem Detayları

Folding Sliding System Detail

Katlanır Kapı Sistem Detayı

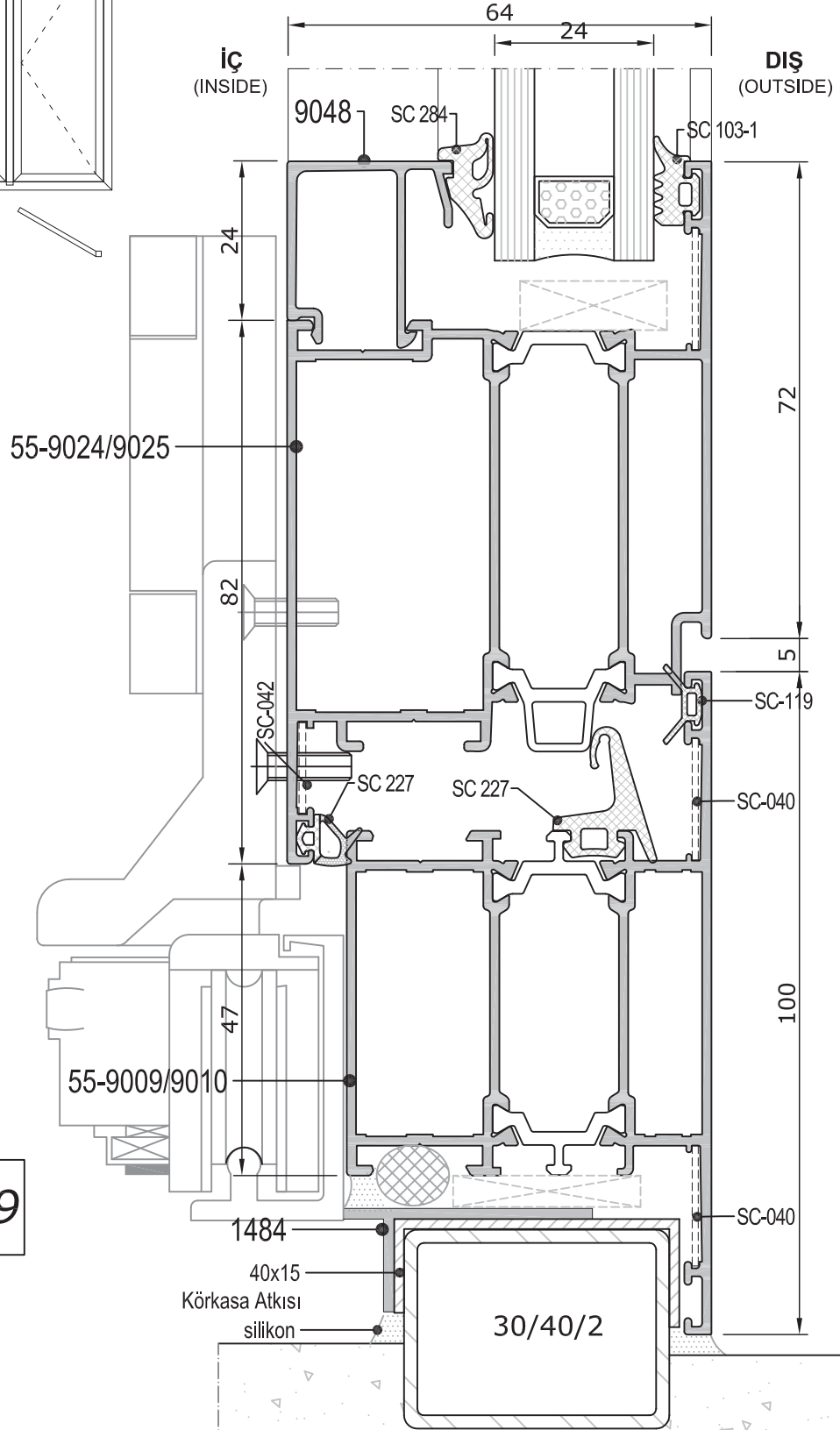
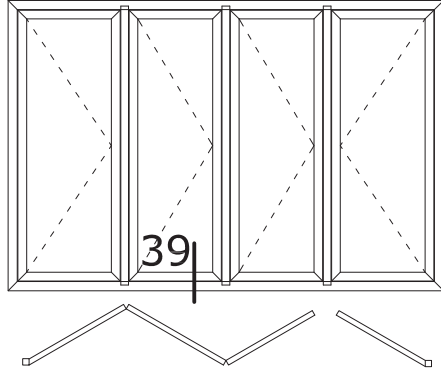

Detay
Detail 39

Typical System Detail Prensip Sistem Detayları

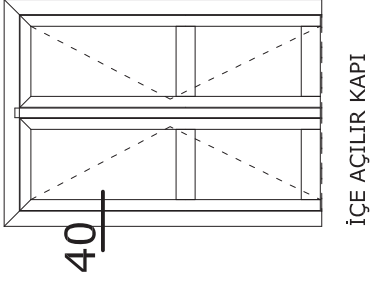

Inside Opening Door System Detail

İçer Açılır Binili Kapı Sistem Detayı

- SC-804
- SC-805
- SC-806
- SC-807

Detay 40
Detail

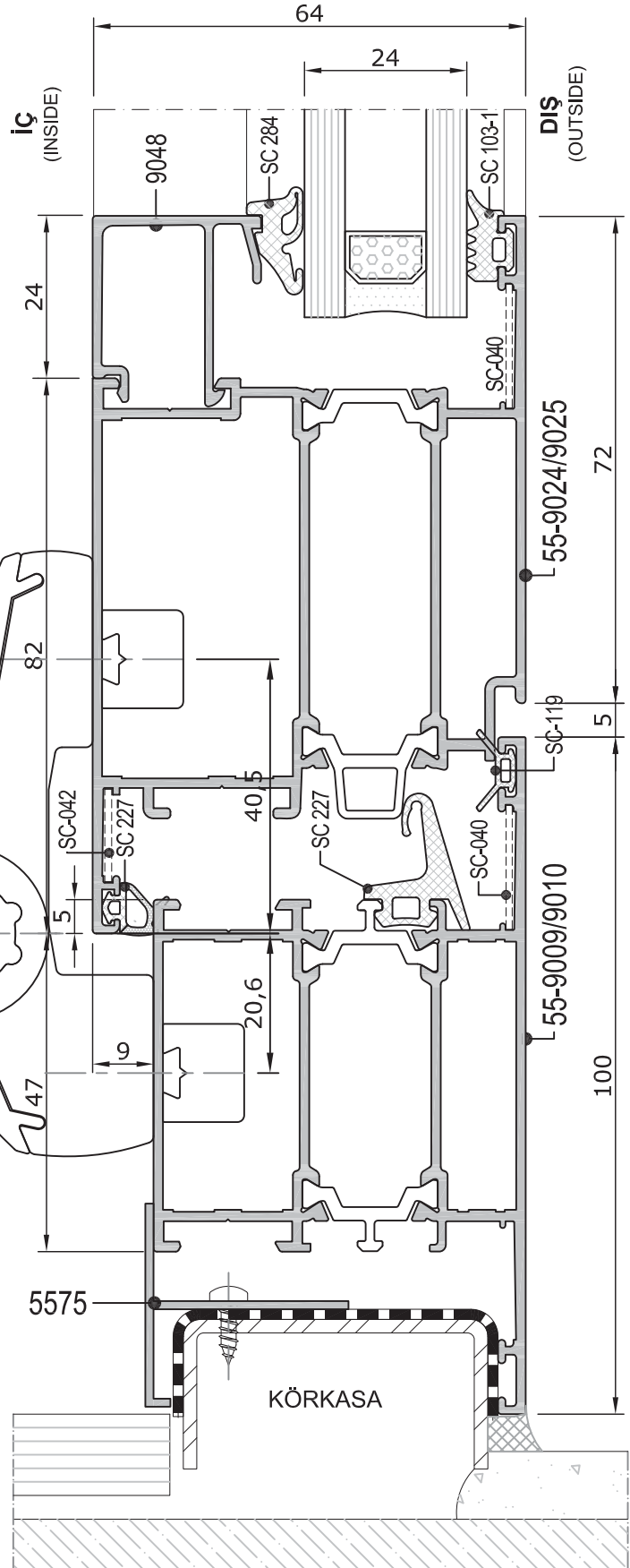

Typical System Detail Prensip Sistem Detayları

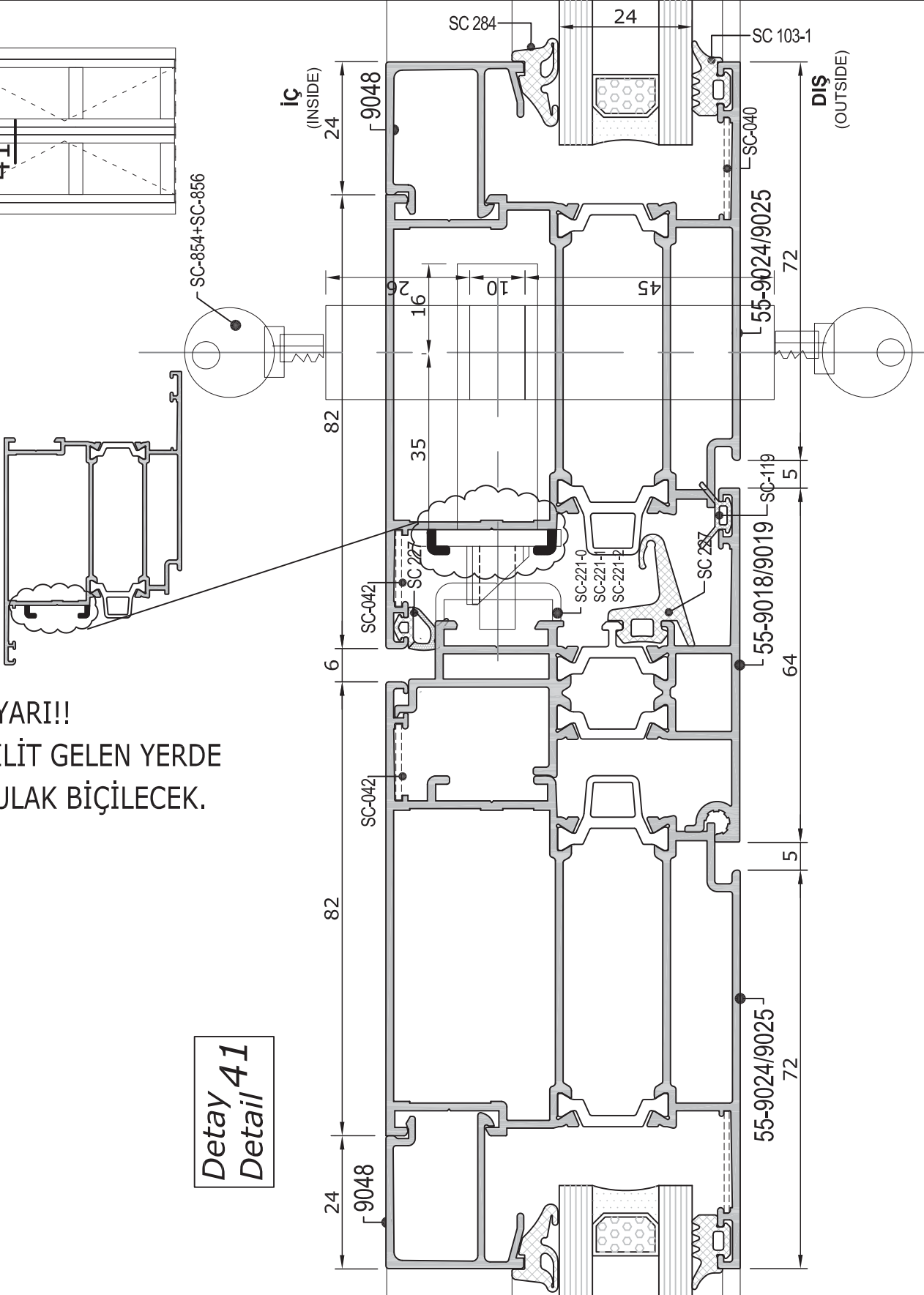
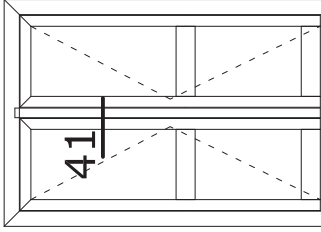

UYARI!!
KİLİT GELEN YERDE
KULAK BİÇİLECEK.

Detay 41
Detail

Typical System Detail
Prensip Sistem Detayları

Inside Opennig Door System Detail
İçte Açılır Binili Kapı Sistem Detayı

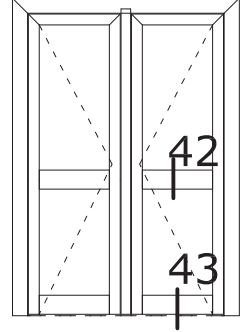

Detay
Detail 42

Detay
Detail 43

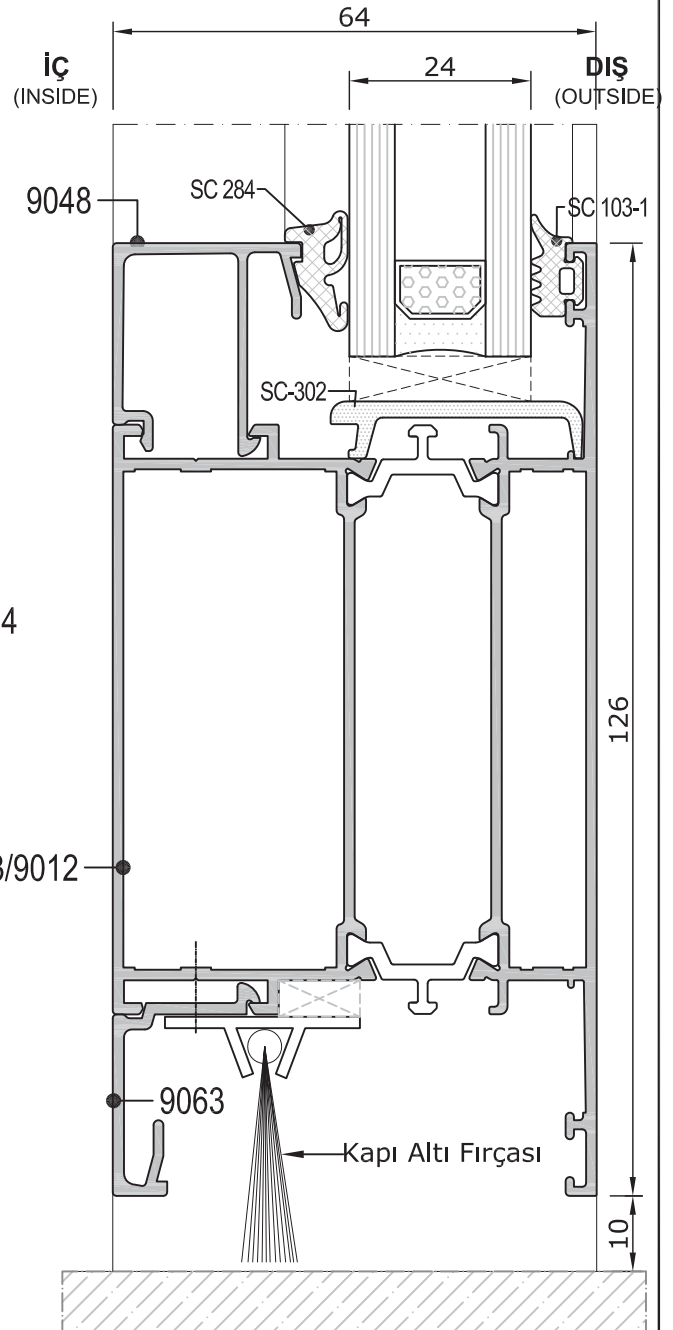
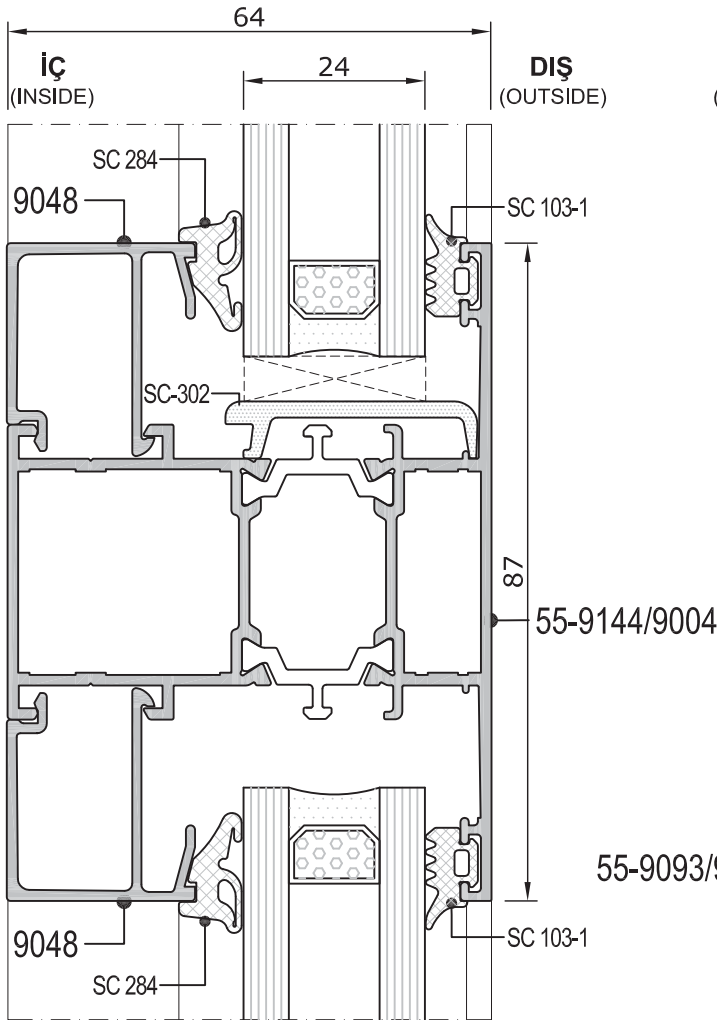

Typical System Detail
Prensip Sistem Detayları

Inside Openning Flat Door System Detail
İçe Açılır Hemyüz Kapı Sistem Detayı

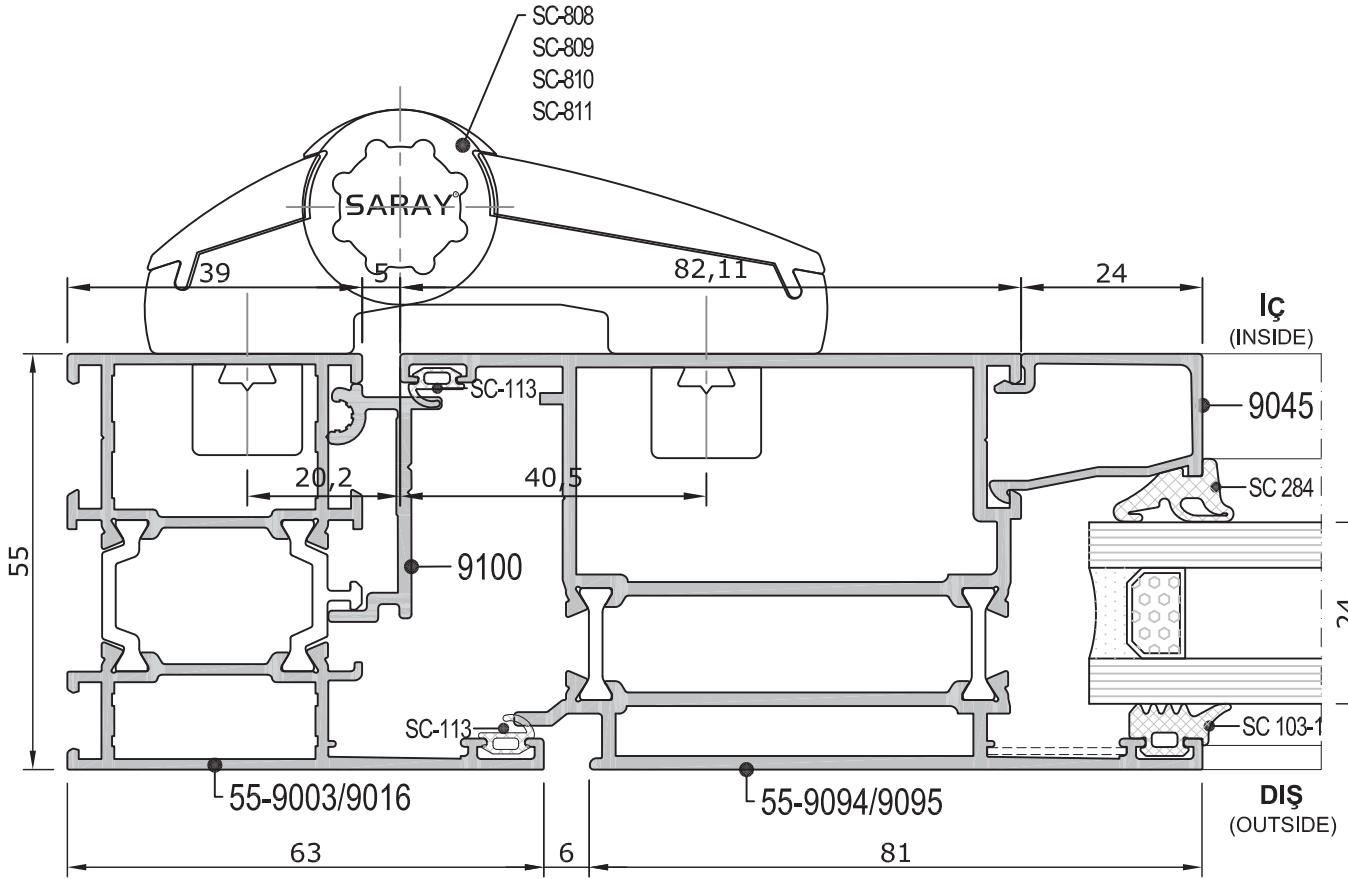
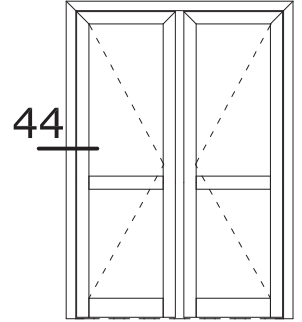

Detay 44
Detail 44

Typical System Detail
Prensip Sistem Detayları

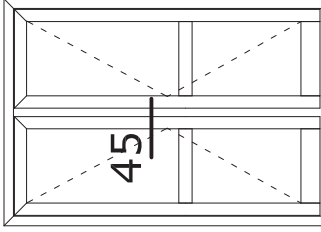

Inside Opening Flat Door System Detail

İçeride Açılır Hemyüz Kapı Sistem Detayı

Detay 45
Detail

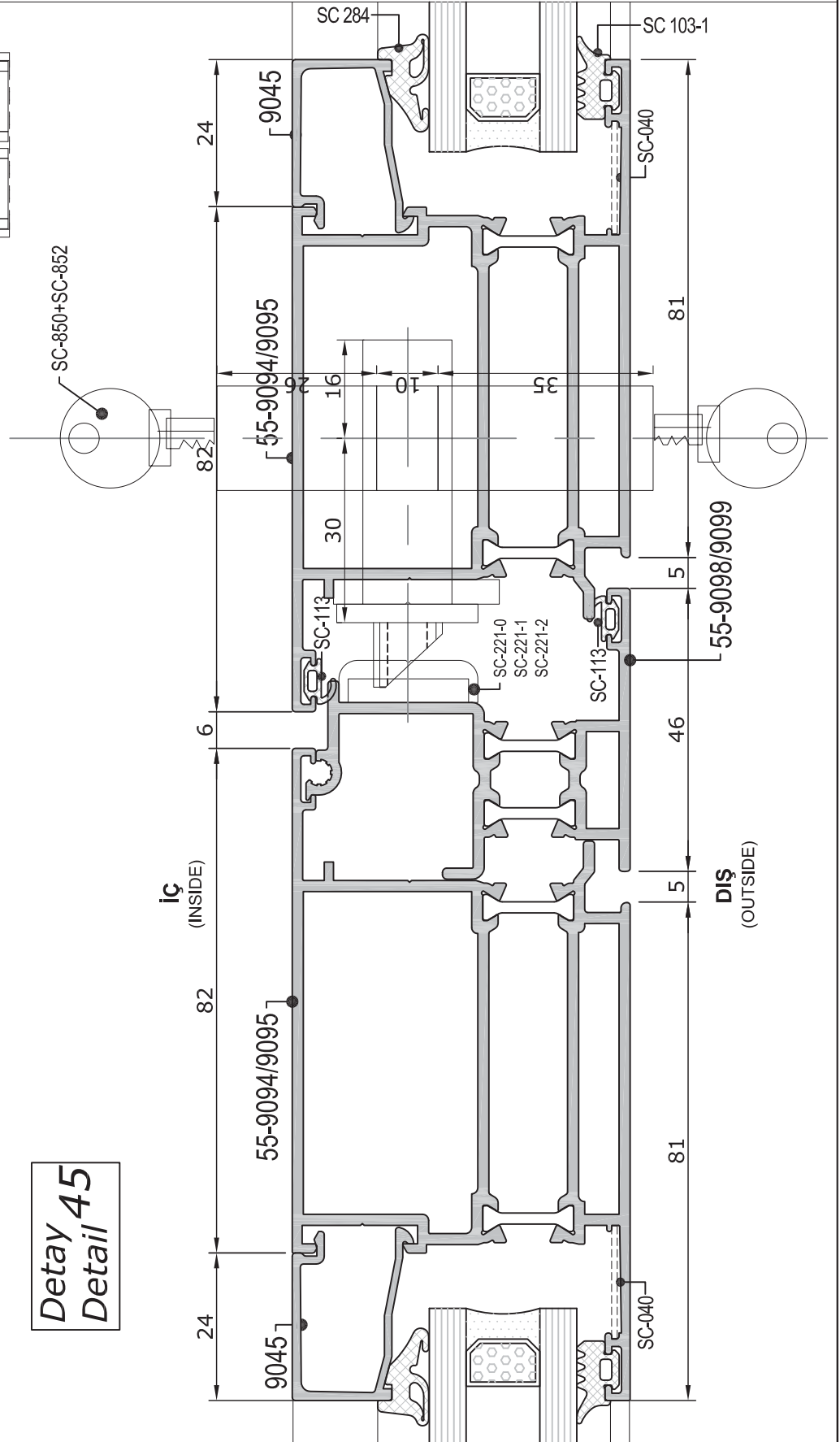

Typical System Detail
Prensip Sistem Detayları

Outside Opennig Flat Door System Detail
Dışa Açılır Hemyüz Kapı Sistem Detayı

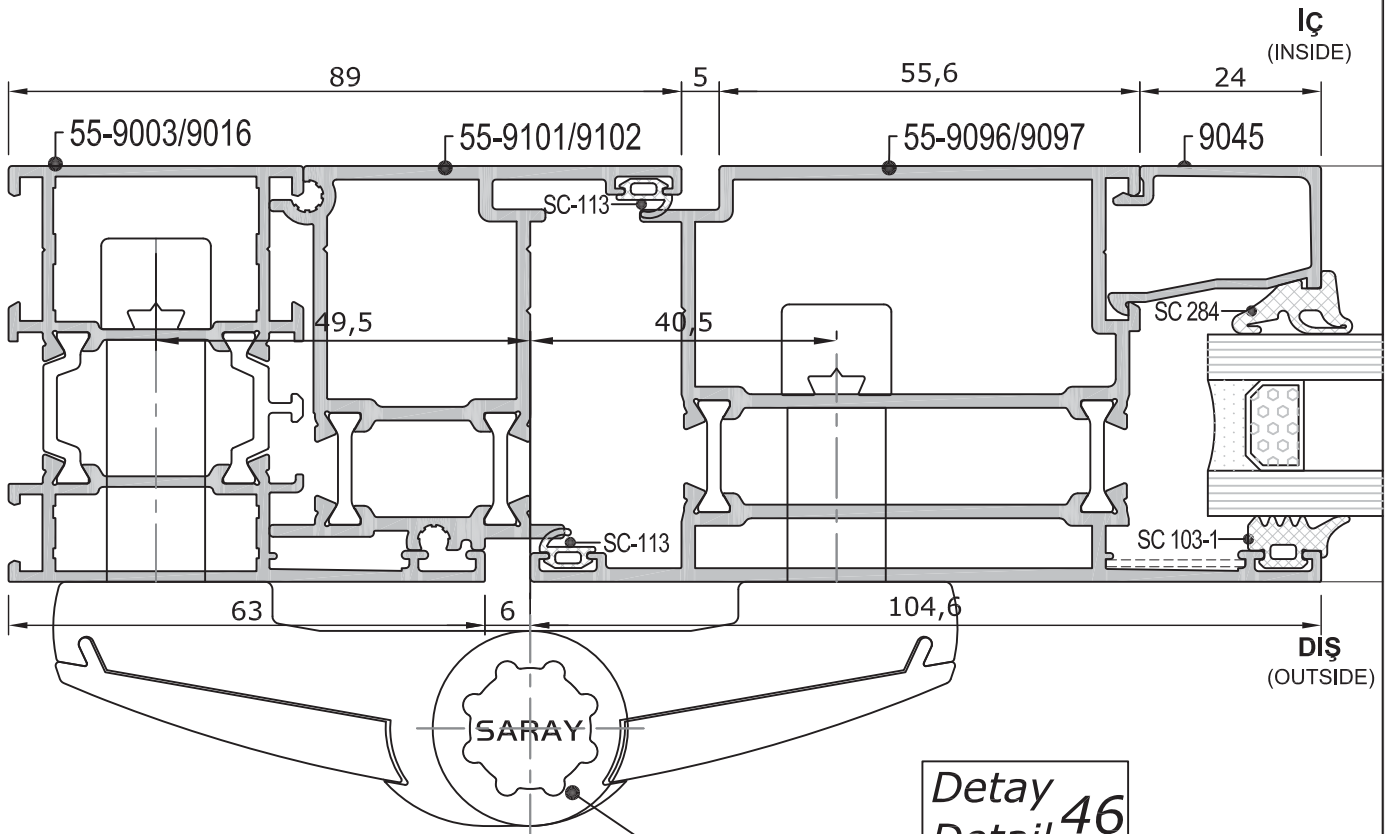
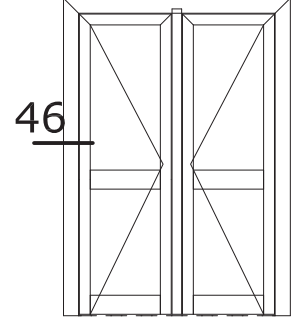

Detay
Detail 46

- SC-812
- SC-813
- SC-814
- SC-815

NOT: MENTEŞE İÇİN BURÇ İSTENİYORSA SİPARİŞTE
SİSTEM İSMİ İLE BELİRTİLMESİ GEREKMEKTEDİR.

Typical System Detail
Prensip Sistem Detayları

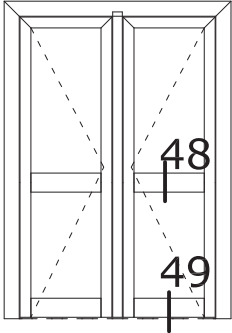

Inside or Outside Openning Flat Door System Detail
İçe veya Dışa Açılır Hemyüz Kapı Sistem Detayı

Detay
Detail 49

Detay
Detail 48

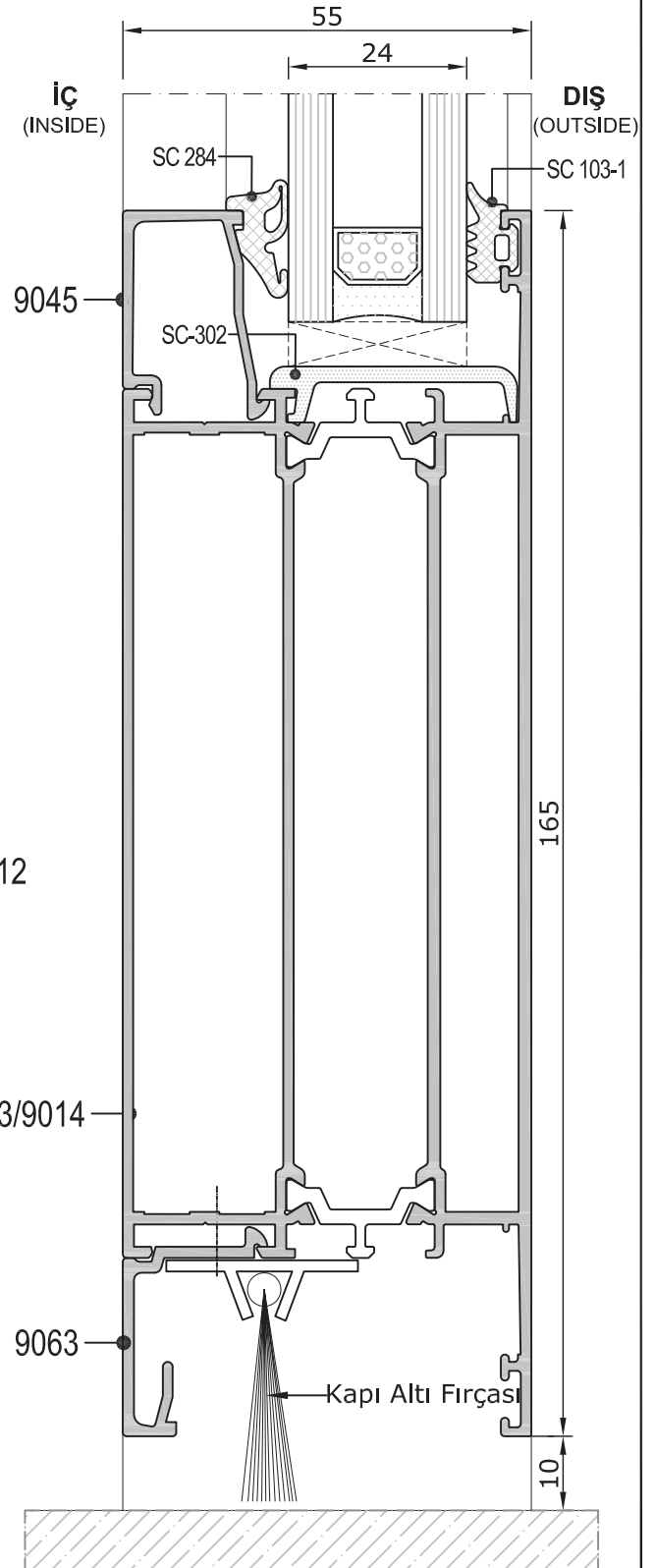
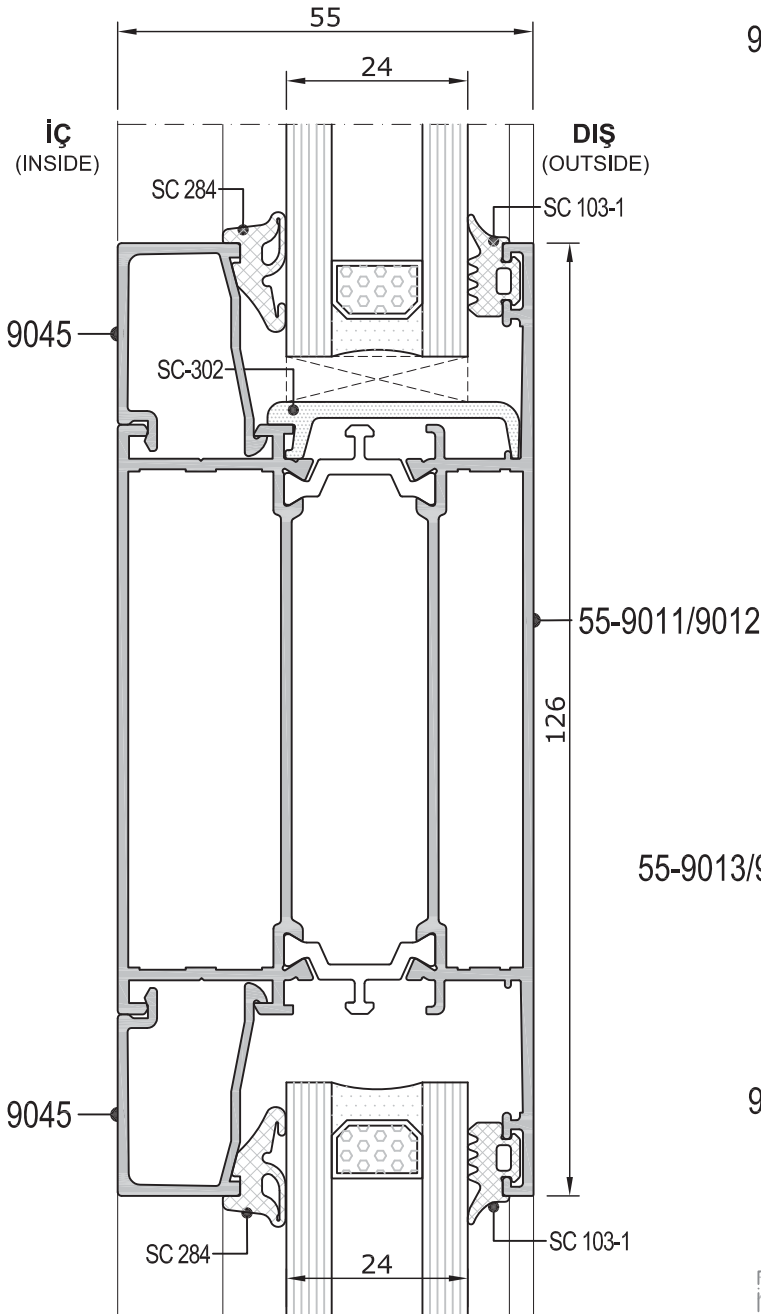

Typical System Detail Prensip Sistem Detayları

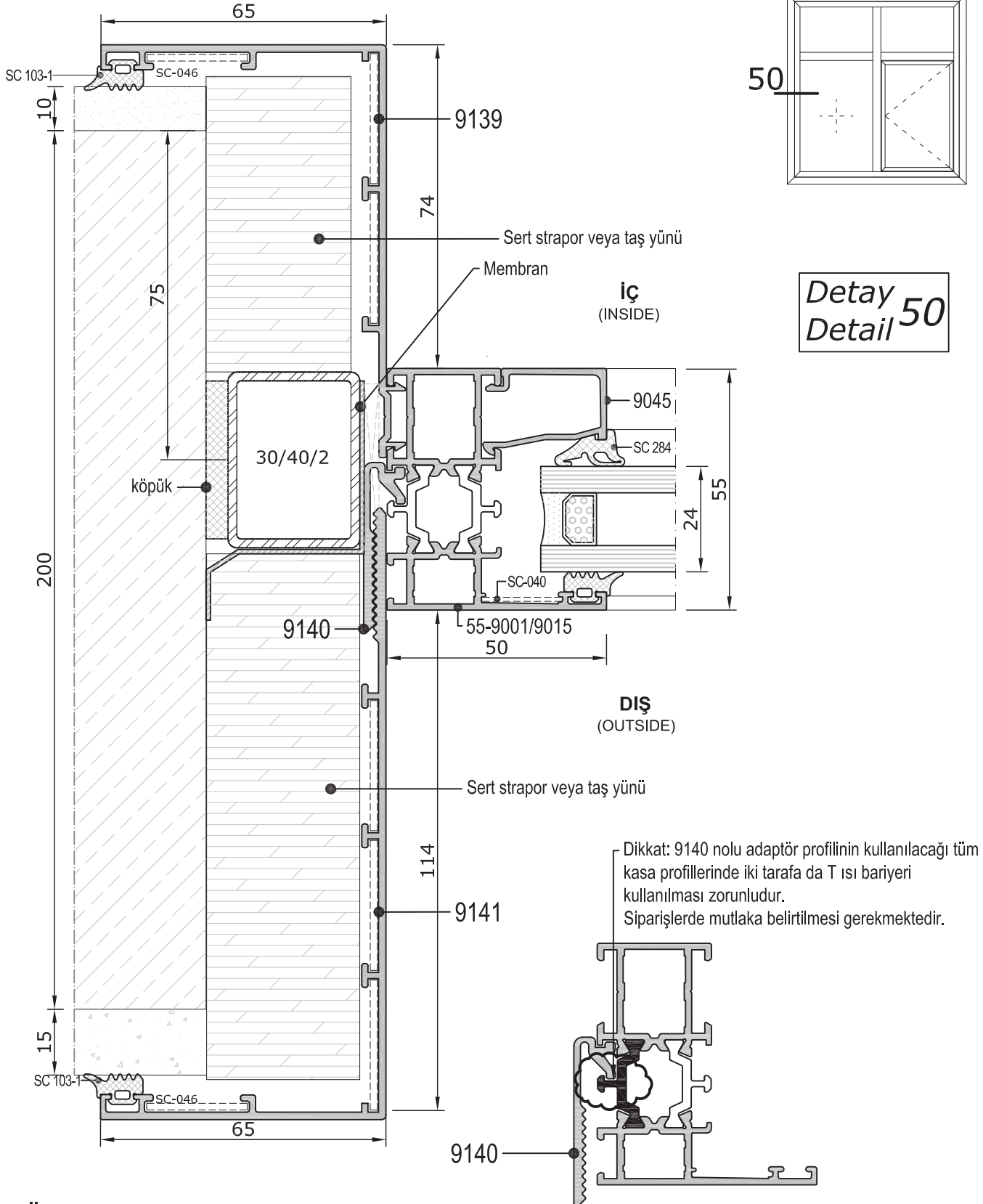

ÖLÇEK: 1/2.5

Typical System Detail
Prensip Sistem Detayları

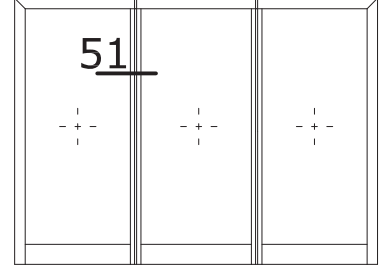

Detay
Detail 51

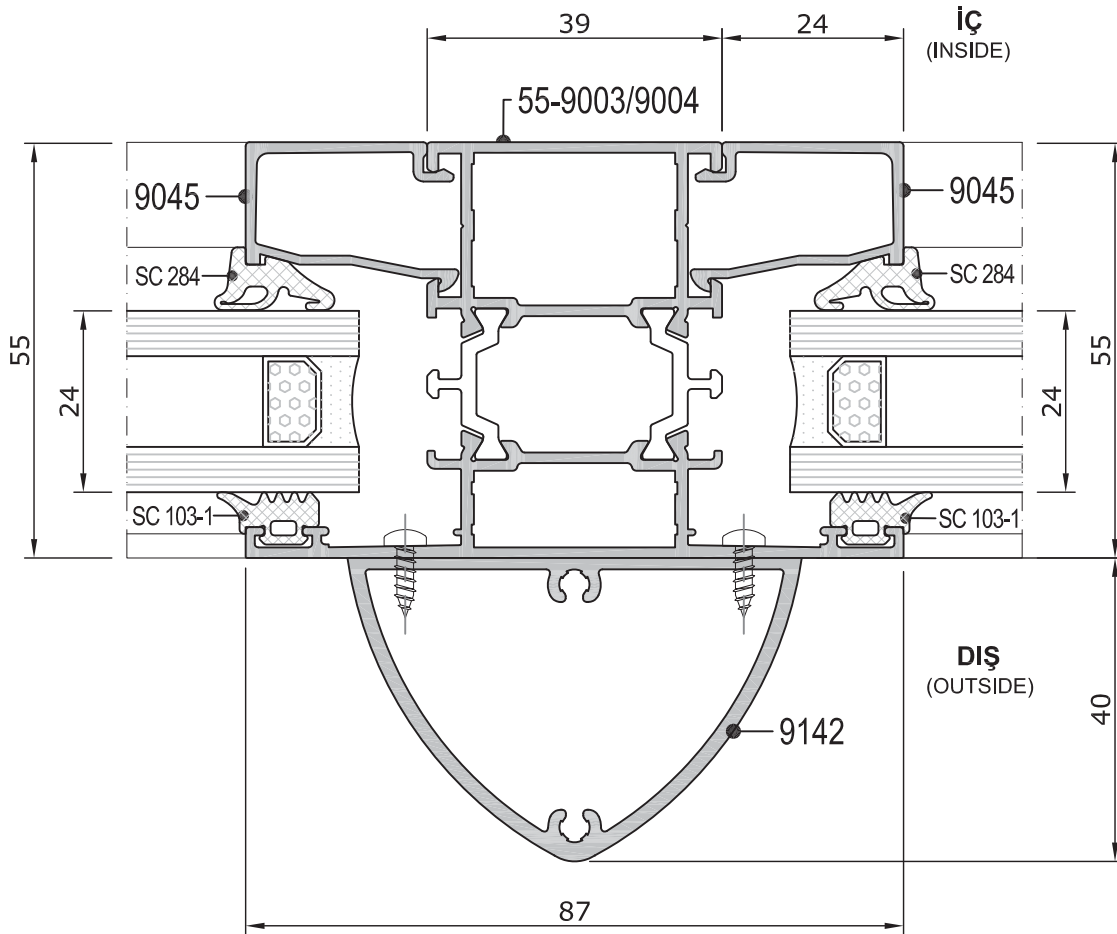

NOT: Toplam Jx değeri 58,06 cm⁴ tür.

**EW55
WINDOWS and DOORS
SYSTEM
FABRICATION and CUTTING**

**EW55 KAPI ve PENCERE
SİSTEMİ
ÜRETİM İŞLEMLERİ**

Two Wings Windows Adapteur Plug Assembly
Çift Kanat Adaptörü Montaj Şeması

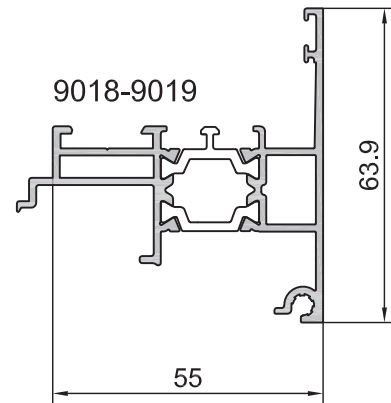
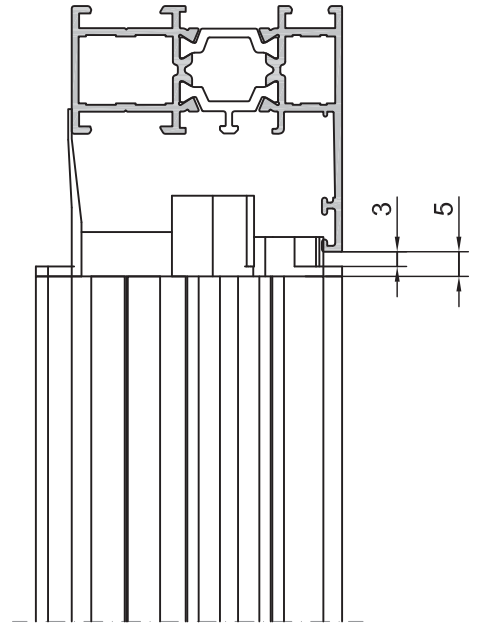
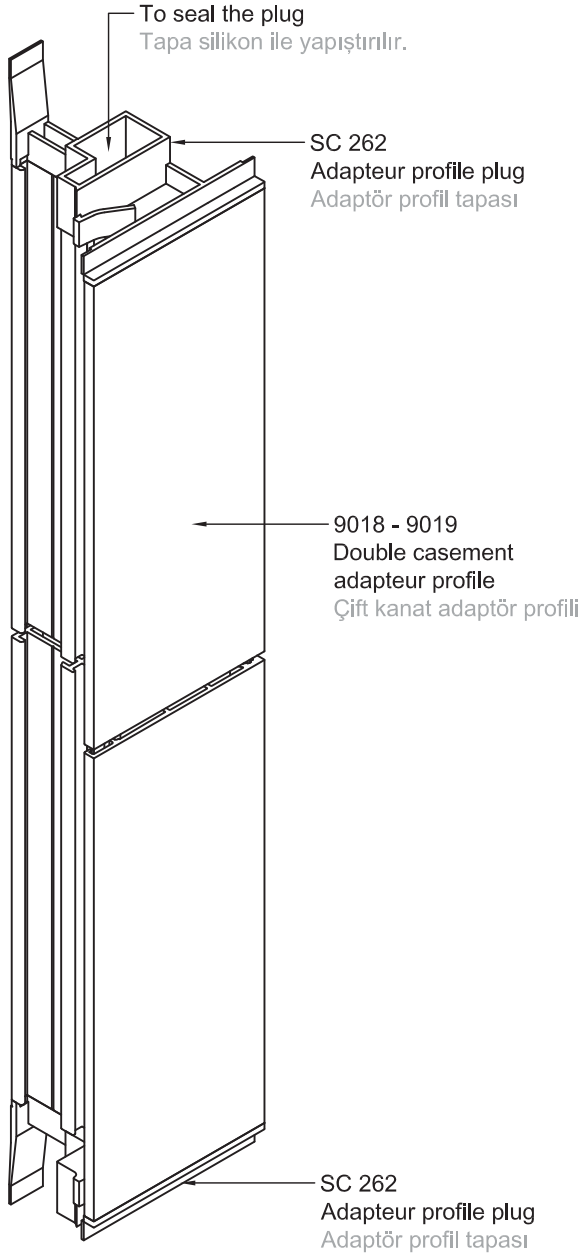

Cutting and Sealing Central Gasket
Merkezi Sızdırmazlık Contası Montaj Şeması

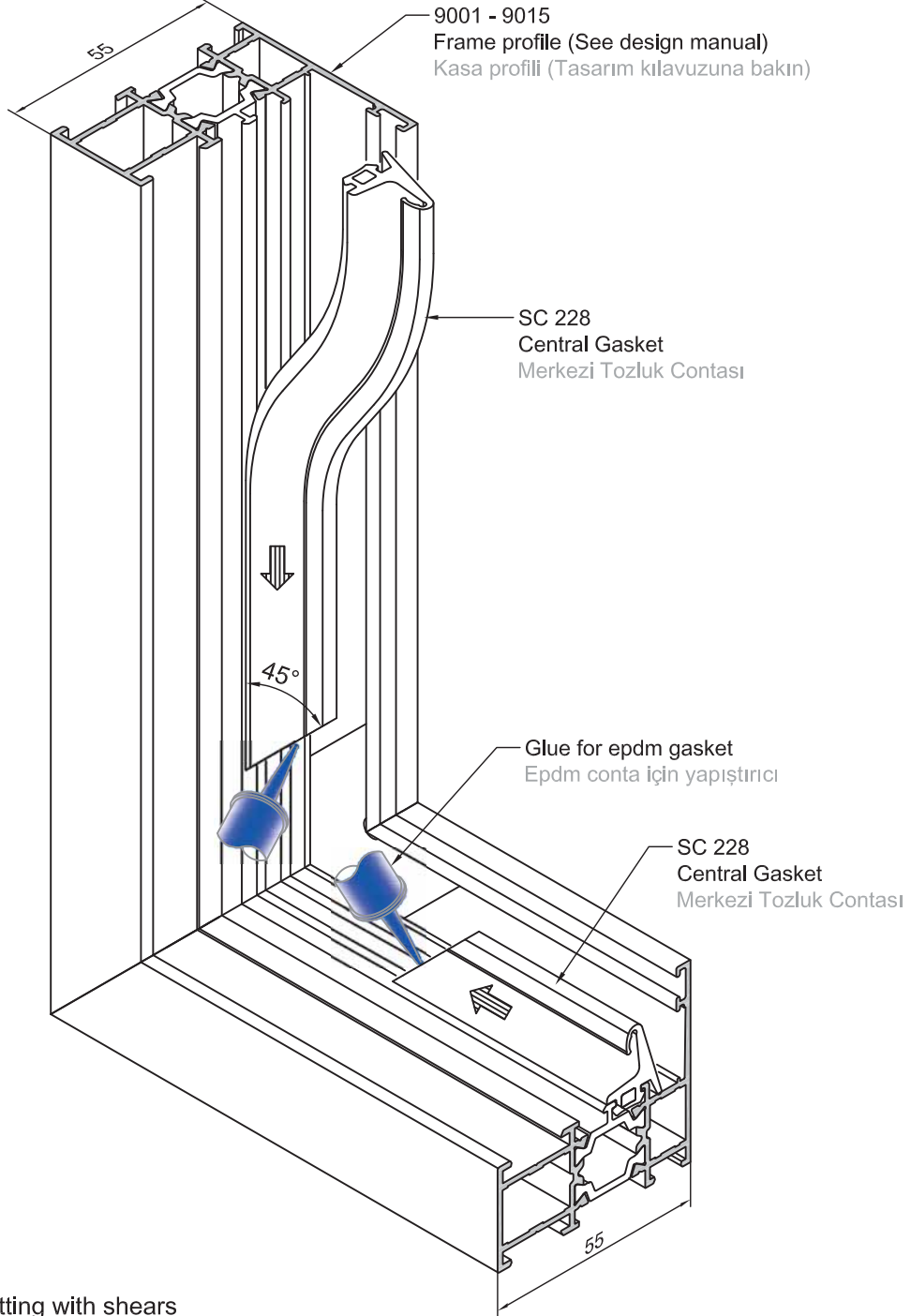

- 1-Correct cutting with shears
Makaslar ile contanın doğru kesilmesi
- 2-Necessary overhanging : $\pm 10\text{mm/m}$
Merkezi conta her metre başına $\pm 10\text{mm}$ uzun kesilmelidir.
- 3-Applying central gasket and compressing overhanging
Merkezi contayı sıkıştırma yapılarak yerine takılır.
- 4-Glueing mitres by means of glue for corner connections
Köşeli birleşen conta uçları yapıştırılarak birleştirilmelidir.

Cutting and Sealing Central Gasket
Merkezi Sızdırmazlık Contası Montaj Şeması

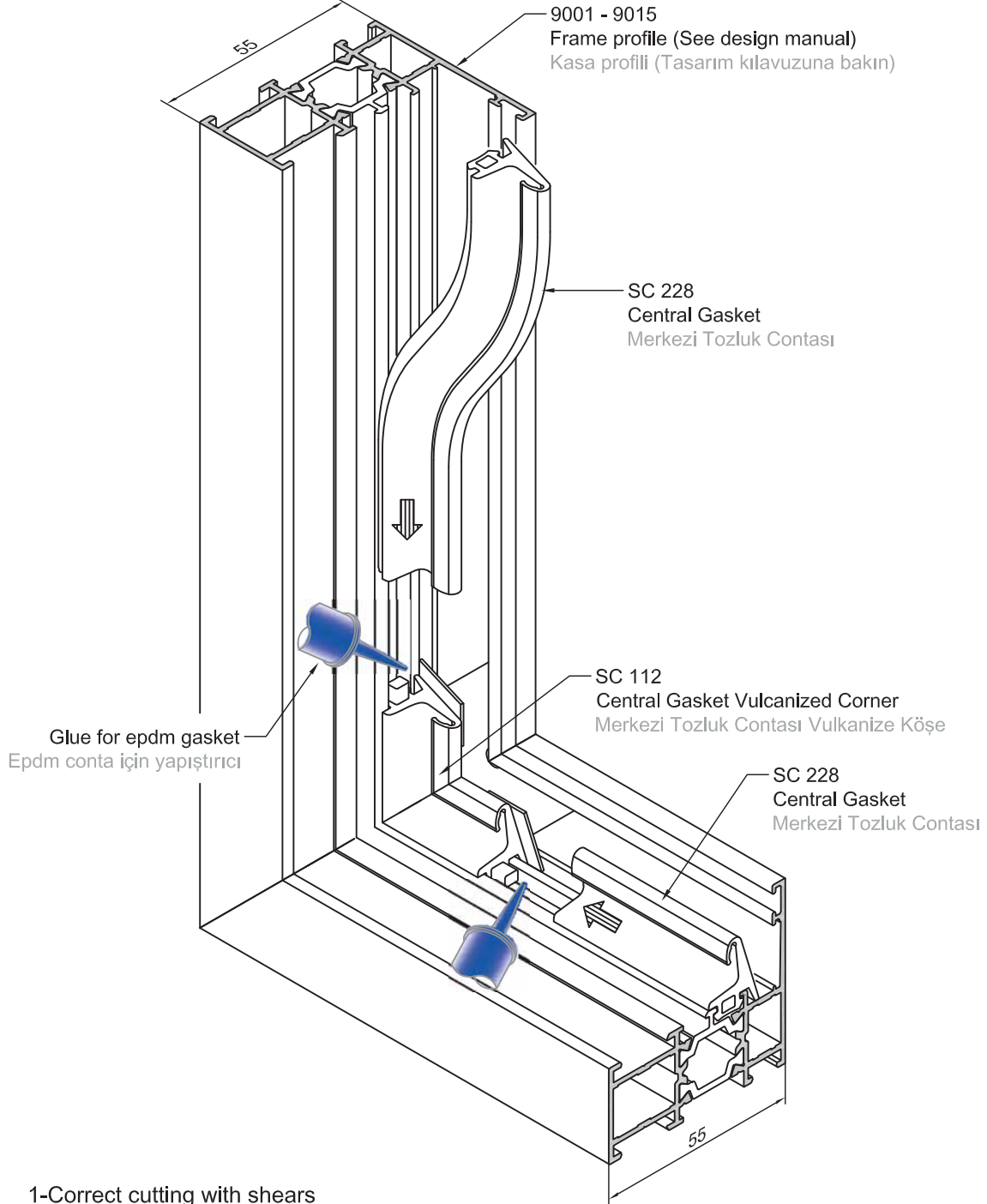

- 1-Correct cutting with shears
Makaslar ile contanın doğru kesilmesi
- 2-Necessary overhanging : $\pm 10\text{mm/m}$
Merkezi conta her metre başına $\pm 10\text{mm}$ uzun kesilmelidir.
- 3-Applying central gasket and compressing overhanging
Merkezi contayı sıkıştırma yapılarak yerine takılır.
- 4-Glueing mitres by means of glue for corner connections
Köşeli birleşen conta uçları yapıştırılarak birleştirilmelidir.

Interior Glazing Gasket Assembly İç Cam Contası Montaj Şeması

Glazing bead assembly sequence Cam çtası montaj sıralaması

Gasket (See design manual)
Epdm Conta
(Tasarım kılavuzuna bakın)

Wood edge
Ahşap kama

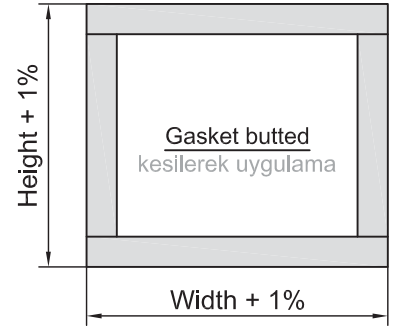
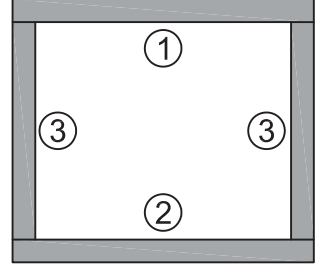
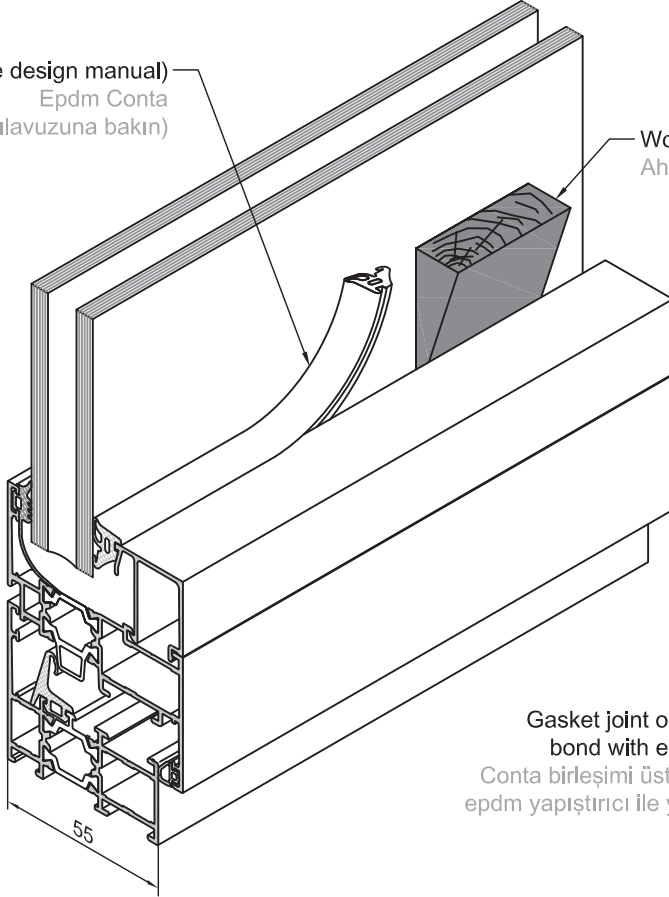

Gasket joint on the top,
bond with epdm glue
Conta birleşimi üstte olmalı,
epdm yapıştırıcı ile yapışmalı

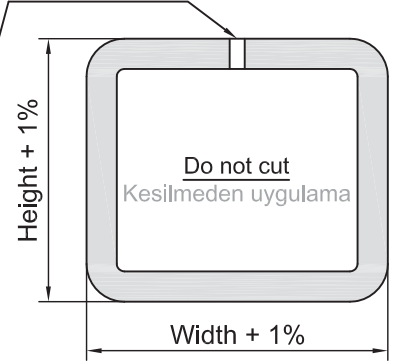

The pane must be shimmed in the sash so that the sash operates without adjustment of the hardware
Donanım ayarı olmadan önce kanat takozlama işlemi yapılmalıdır.

SHIMMING INSTRUCTIONS CAM TAKOZLAMA TALİMATI

① Supporting shim
Taşıyıcı takoz

② Distance shim
Ayar takoz

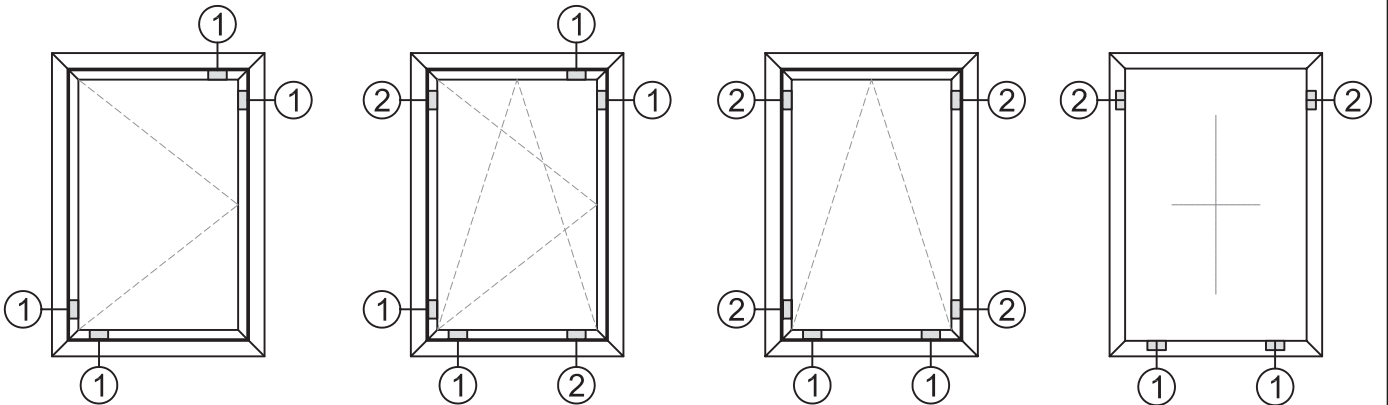

T Joint Assembly Drawing
T Birleşim İşlem Şeması

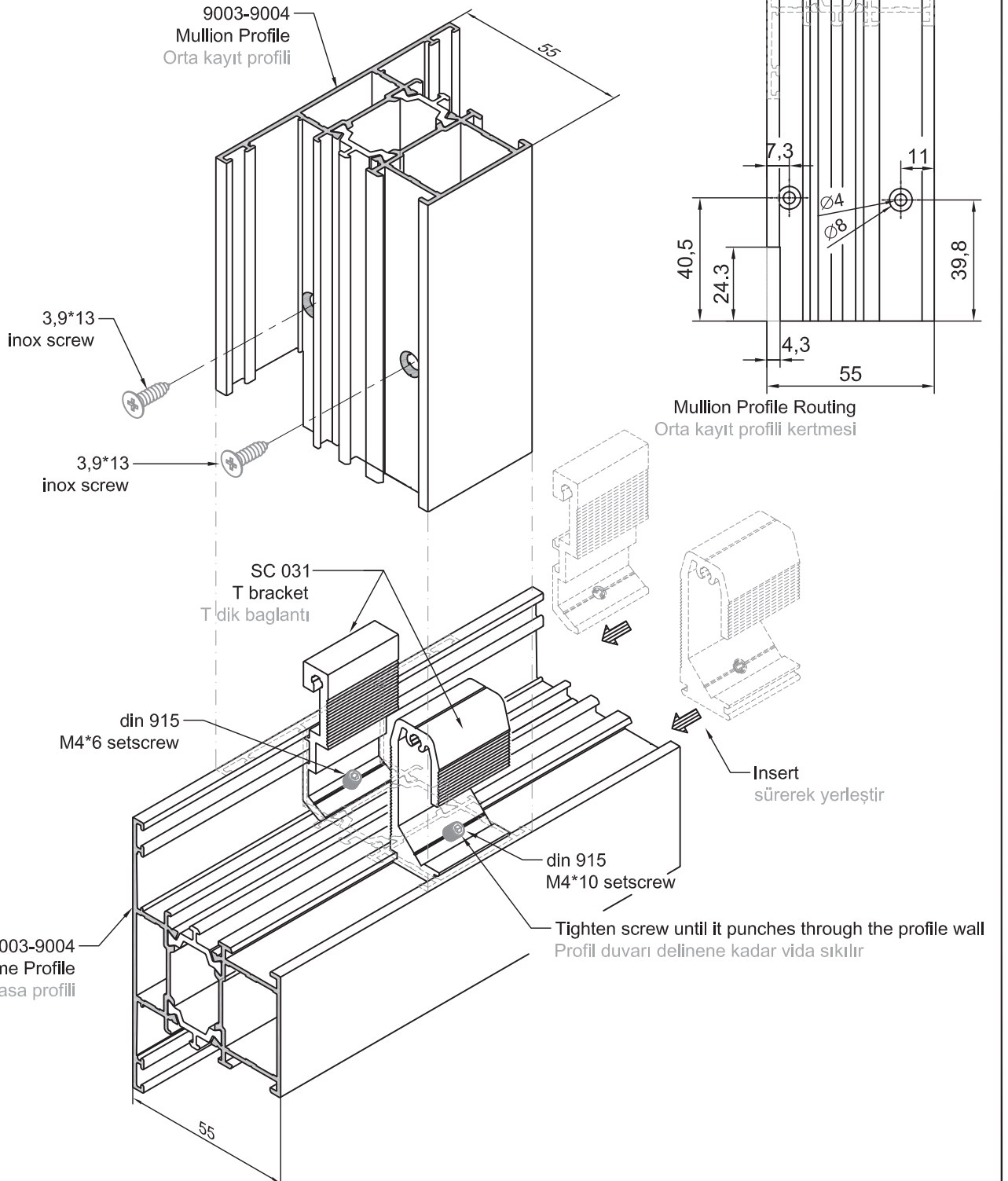

T Joint Assembly Drawing T Birleşim İşlem Şeması

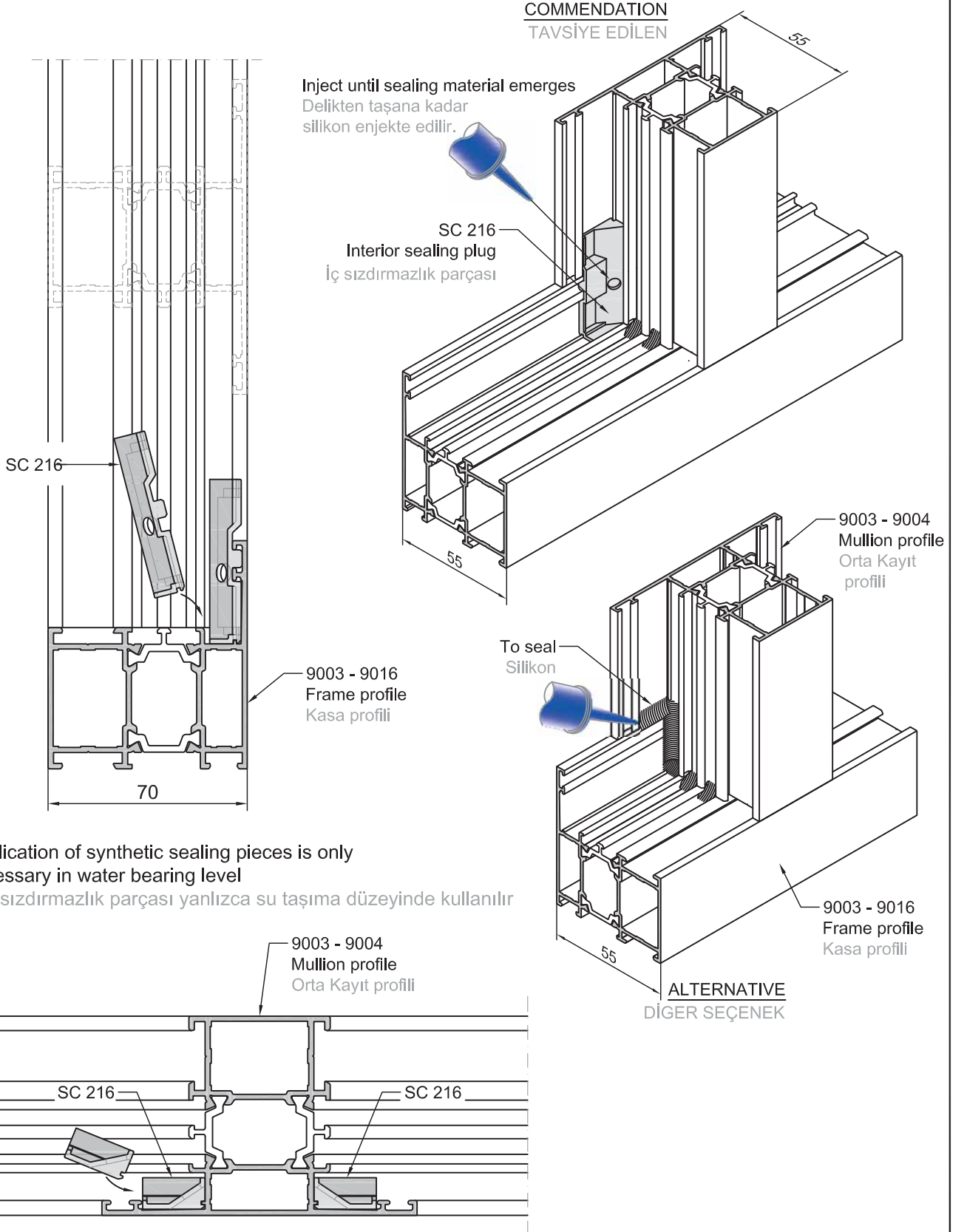

Corner Cleat Assembly Drawing Köşe Takoğu İşlem Şeması

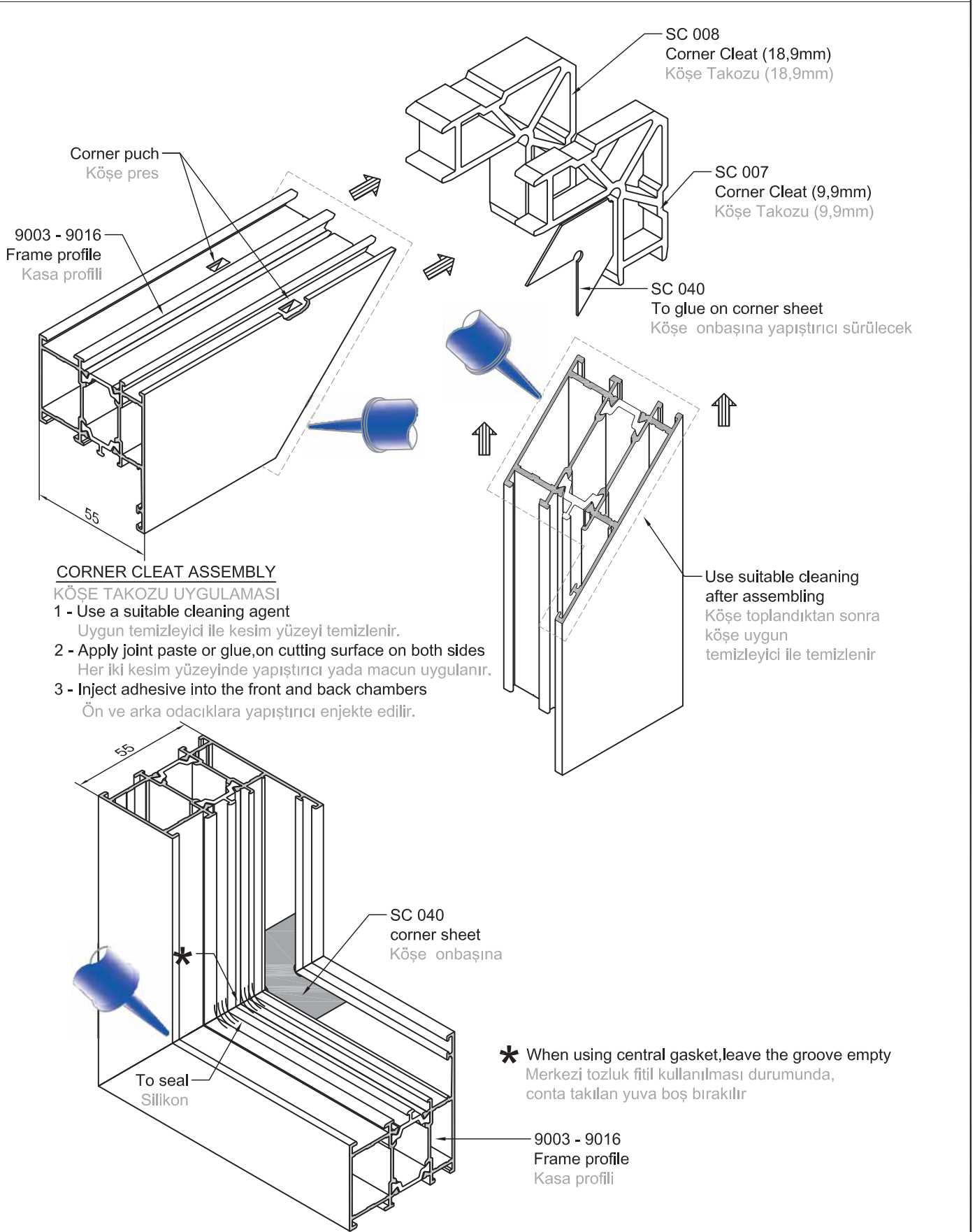

Corner Cleat Assembly Drawing for Sash Kanat için Köşe Takoğu İşlem Şeması

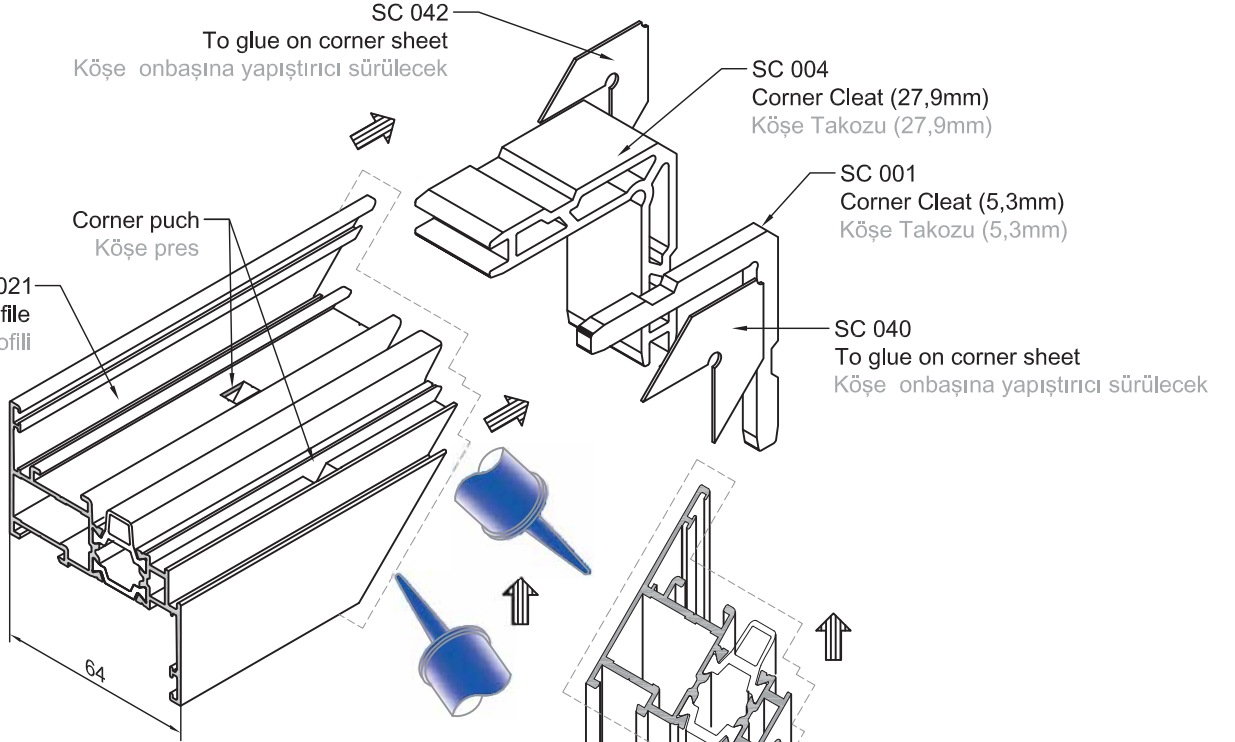

CORNER CLEAT ASSEMBLY

KÖŞE TAKOĞU UYGULAMASI

- 1 - Use a suitable cleaning agent
Uygun temizleyici ile kesim yüzeyi temizlenir.
- 2 - Apply joint paste or glue, on cutting surface on both sides
Her iki kesim yüzeyinde yapıştırıcı yada macun uygulanır.
- 3 - Inject adhesive into the front and back chambers
Ön ve arka odacıklara yapıştırıcı enjekte edilir.

Use suitable cleaning after assembling
Köşe toplandıktan sonra köşe uygun
temizleyici ile temizlenir

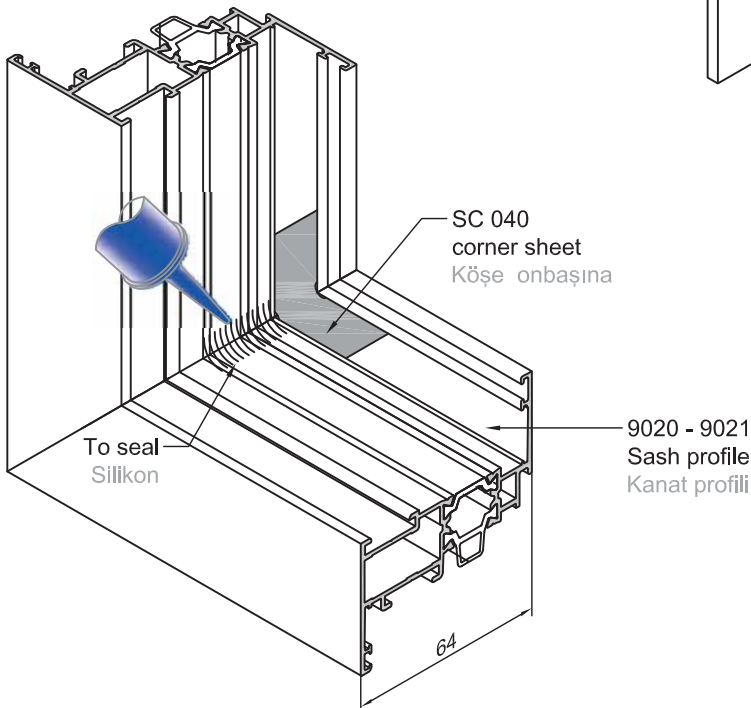

Transom Profile Installing With Screw
Vida Çektirmeli Orta Kayıt Montaj Şeması

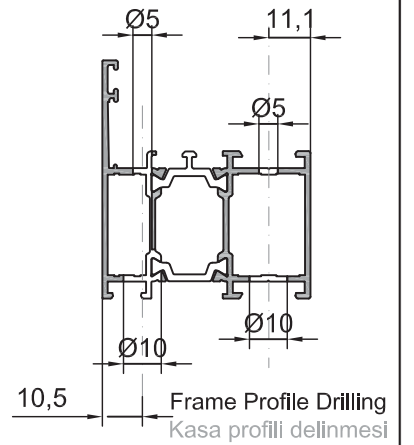
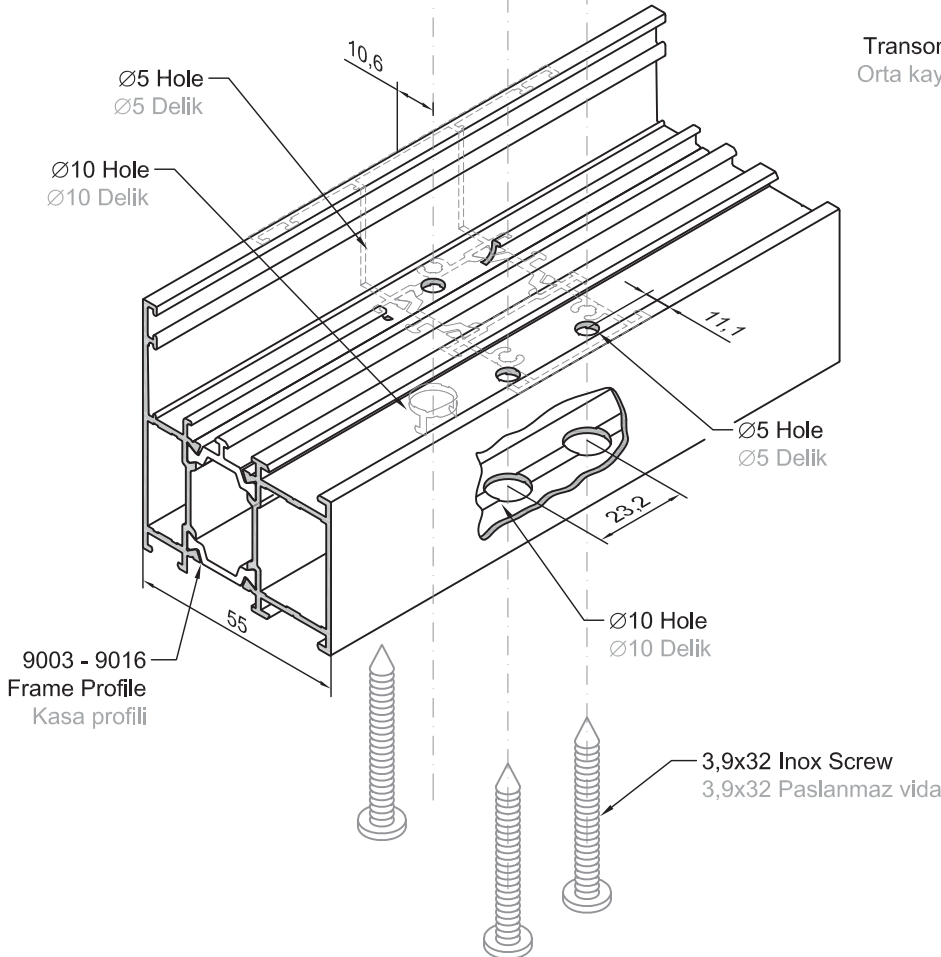
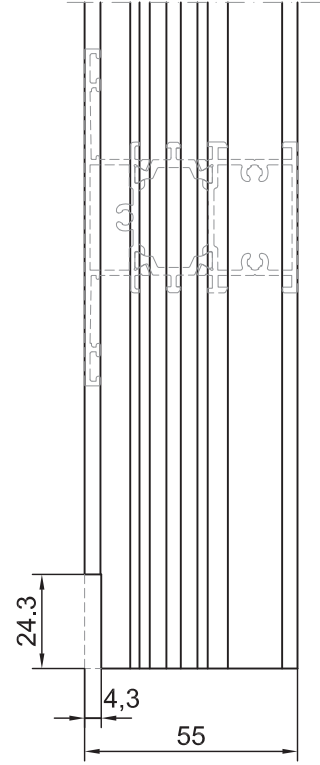
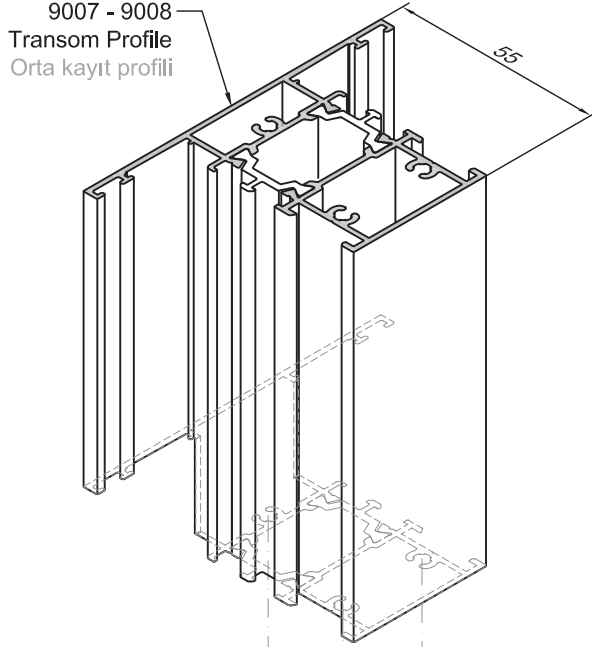

Corner Cleat Assembly Drawing for Hidden Sash Frame Gizli Kanat Kasası için Köşe Takoğu İşlem Şeması

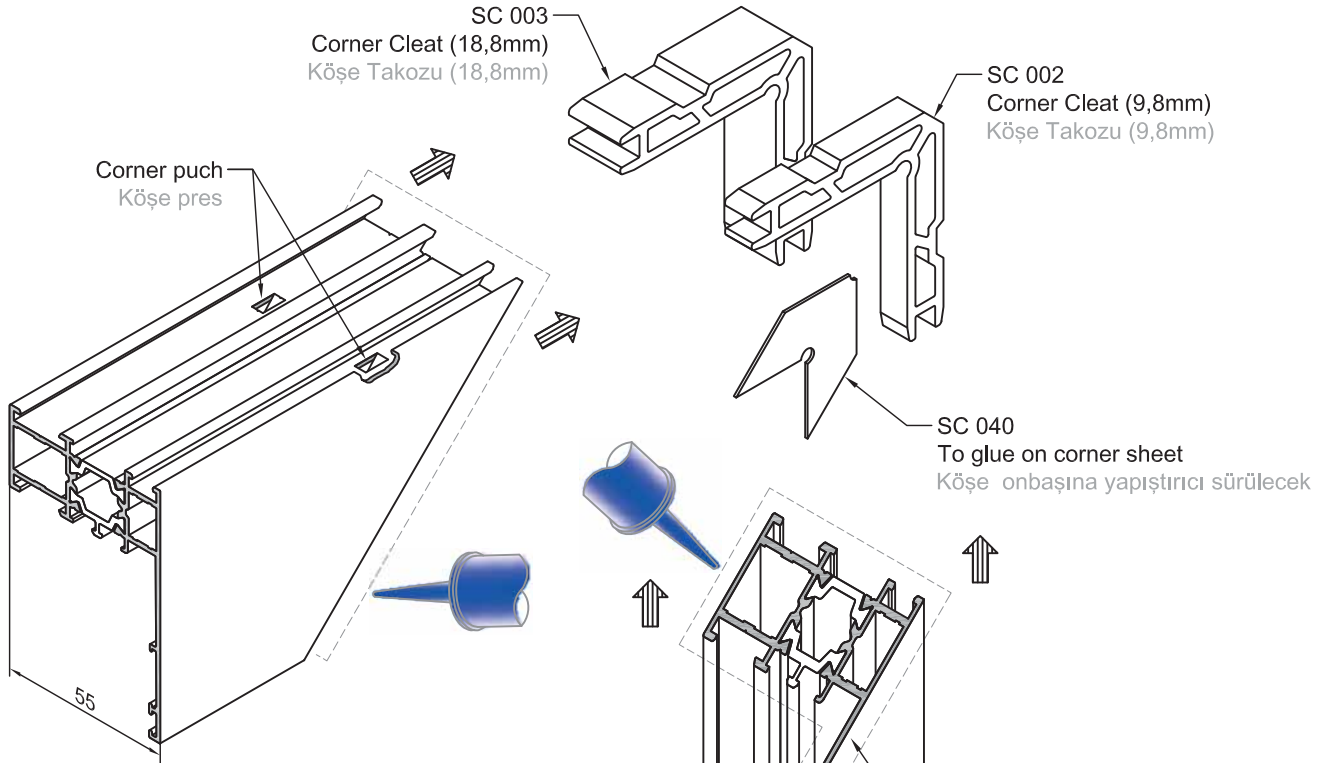

CORNER CLEAT ASSEMBLY

KÖŞE TAKOĞU UYGULAMASI

- 1 - Use a suitable cleaning agent
Uygun temizleyici ile kesim yüzeyi temizlenir.
- 2 - Apply joint paste or glue, on cutting surface on both sides
Her iki kesim yüzeyinde yapıştırıcı yada macun uygulanır.
- 3 - Inject adhesive into the front and back chambers
Ön ve arka odacıklara yapıştırıcı enjekte edilir.

Use suitable cleaning after assembling
Köşe toplandıktan sonra köşe uygun temizleyici ile temizlenir

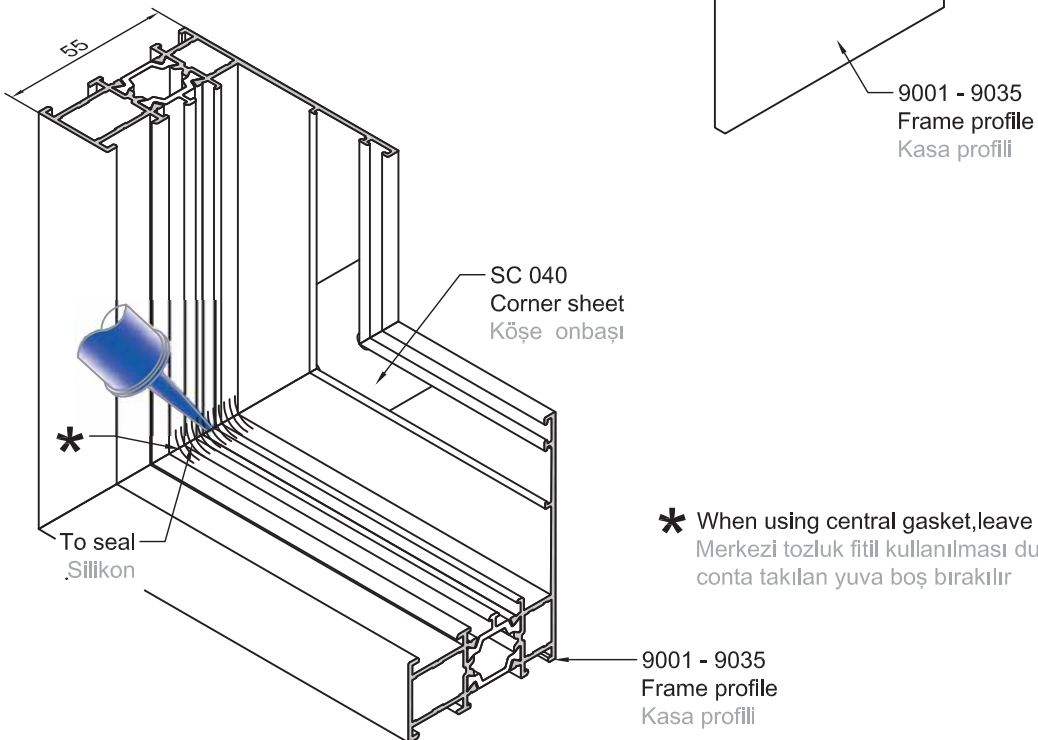

* When using central gasket, leave the groove empty
Merkezi tozluk fitil kullanılması durumunda,
conta takılan yuva boş bırakılır

T Joint Assembly for Hidden Sash
Gizli Kanat için T Birleşim İşlem Şeması

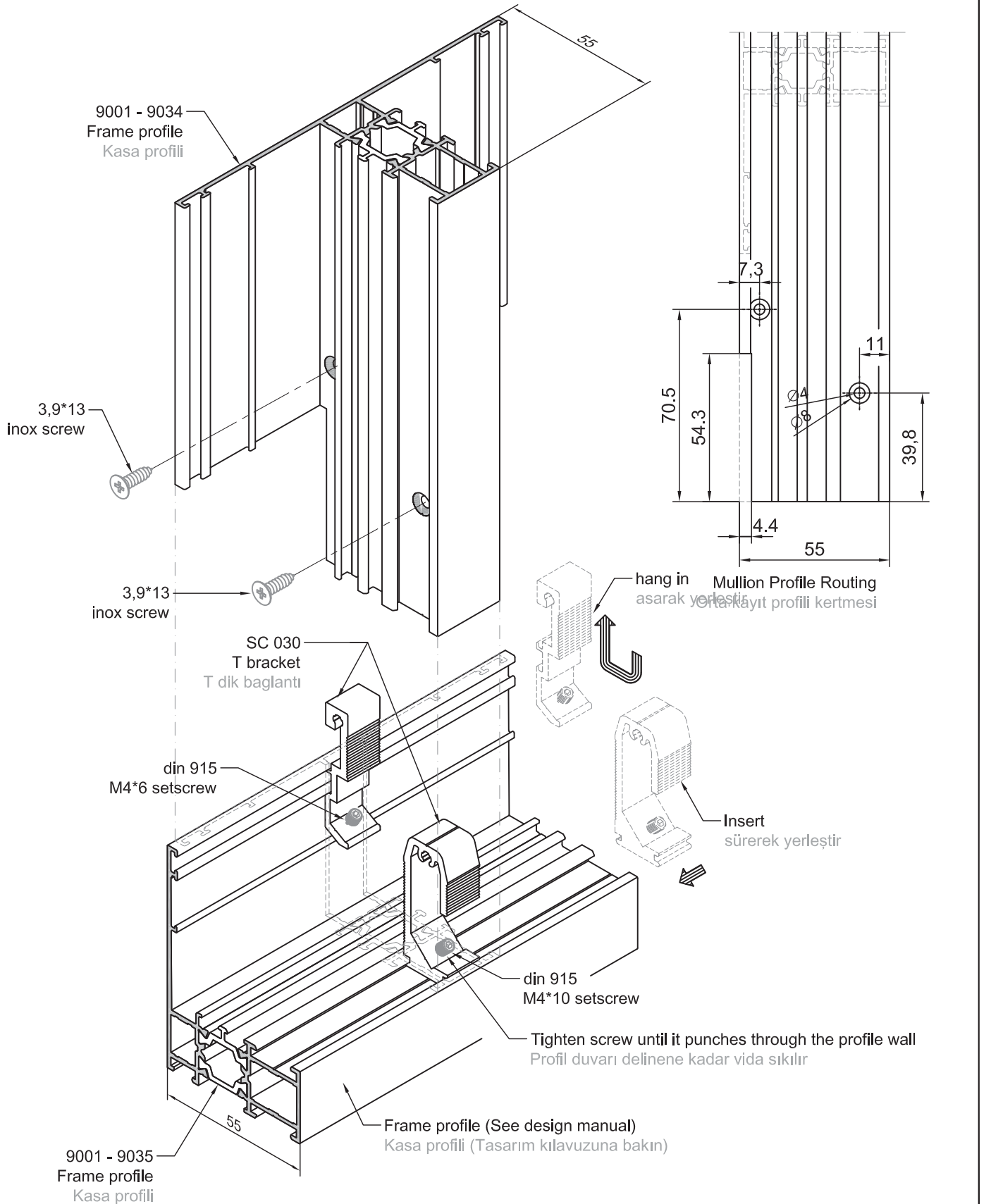

Corner Cleat Assembly for Hidden Sash
Gizli Kanat Köşe Takoz Montaj Şeması

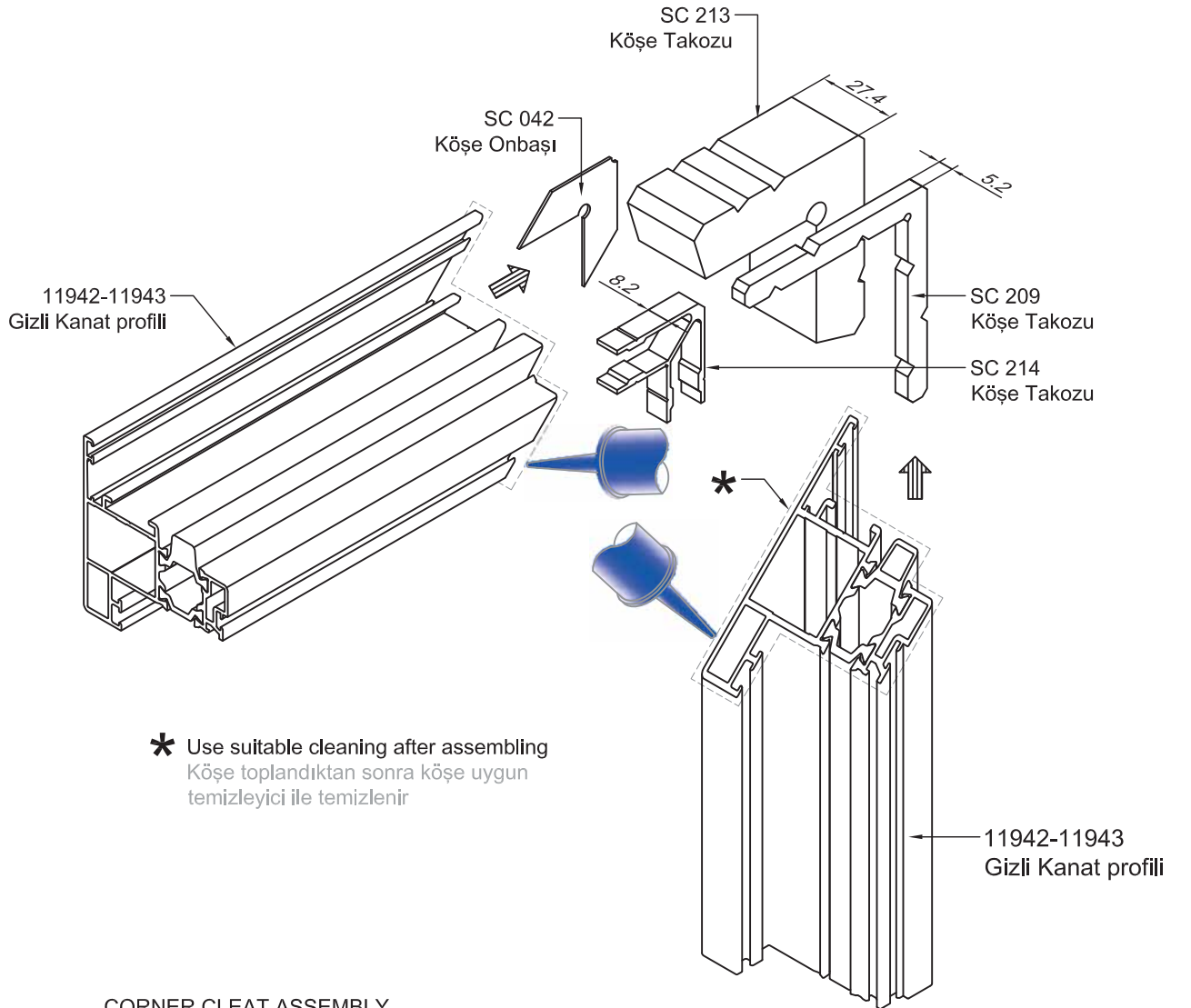

CORNER CLEAT ASSEMBLY
KÖŞE TAKOZU UYGULAMASI

- 1 - Use a suitable cleaning agent
Uygun temizleyici ile kesim yüzeyi temizlenir.
- 2 - Apply joint paste or glue, on cutting surface on both sides
Her iki kesim yüzeyinde yapıştırıcı yada macun uygulanır.
- 3 - Inject adhesive into the front and back chambers
Ön ve arka odacıklara yapıştırıcı enjekte edilir.

Water Drainage and Decompression for Hidden Sash
Gizli Kanat Su Tahliye ve Basınç Dengeleme İşlem Şeması

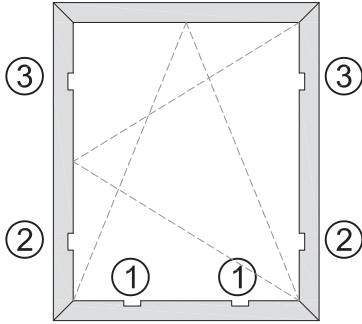
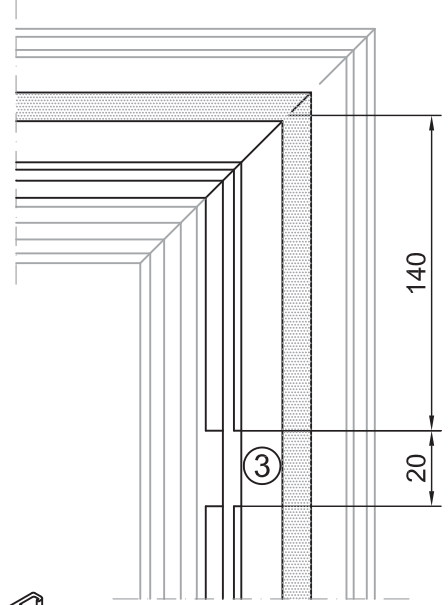
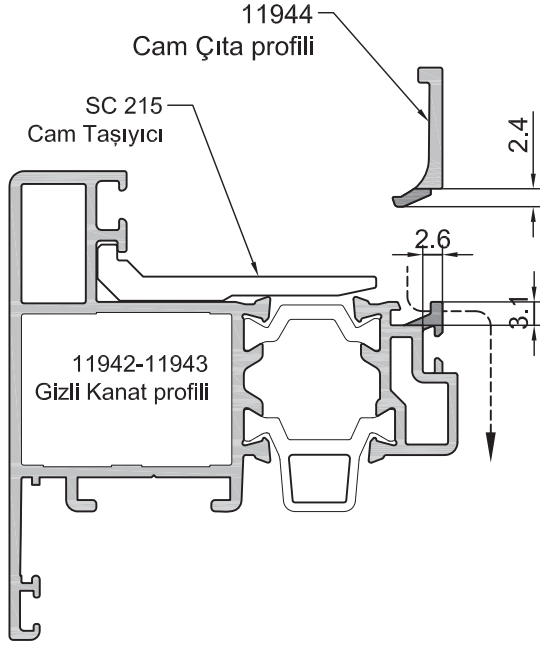

Kanat profili üzerinde
su ve basınç denge delik yerleşimi

11942-11943
Gizli Kanat profili

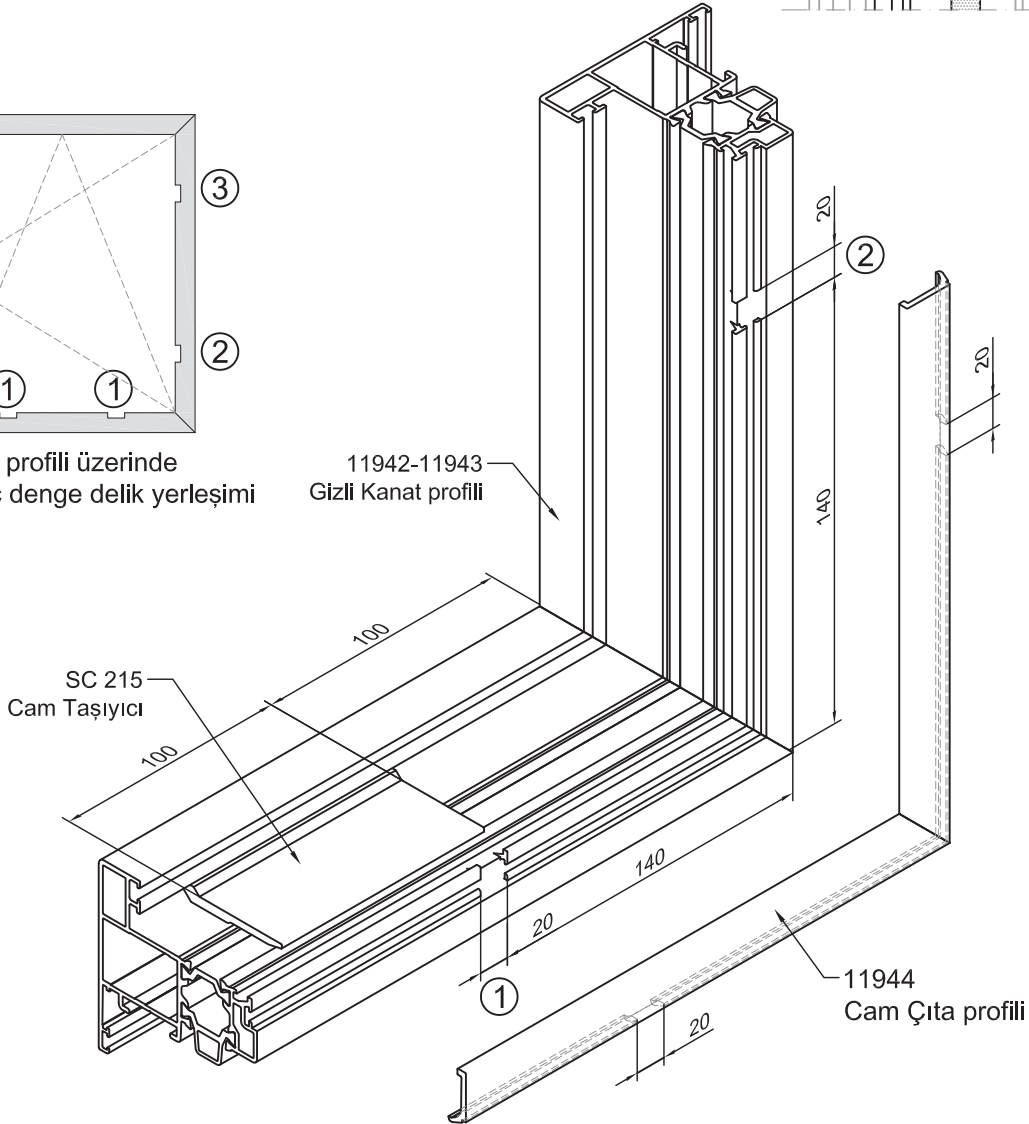

Water Drainage and Decompression for Hidden Sash
Gizli Kanat Su Tahliye ve Basınç Dengeleme İşlem Şeması

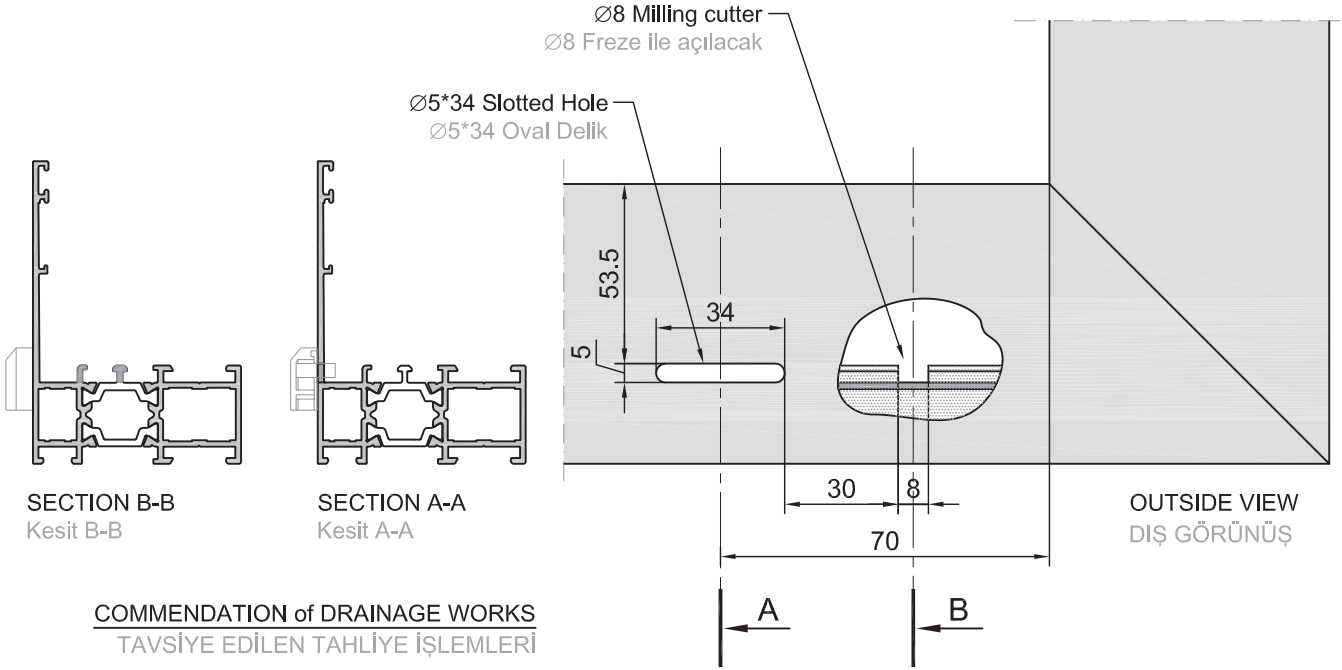

COMMENDATION of DRAINAGE WORKS
TAVSİYE EDİLEN TAHLYE İŞLEMLERİ

- 1 - Correct punching, drilling or milling
Belirtilen delikler için uygun pres freze, kertme yapılmalı.
- 2 - Deburring and Removing dust and saw-dust (if necessary)
Çapaklar ve testere tozları alınmalı (eger gerekli ise)
- 3 - Degreasing with degreaser
Yağ artıkları yağ çözücü ile temizlenmeli
- 4 - Applying anti-corrosion product
Korozyon önleyici ürün uygulanmalı

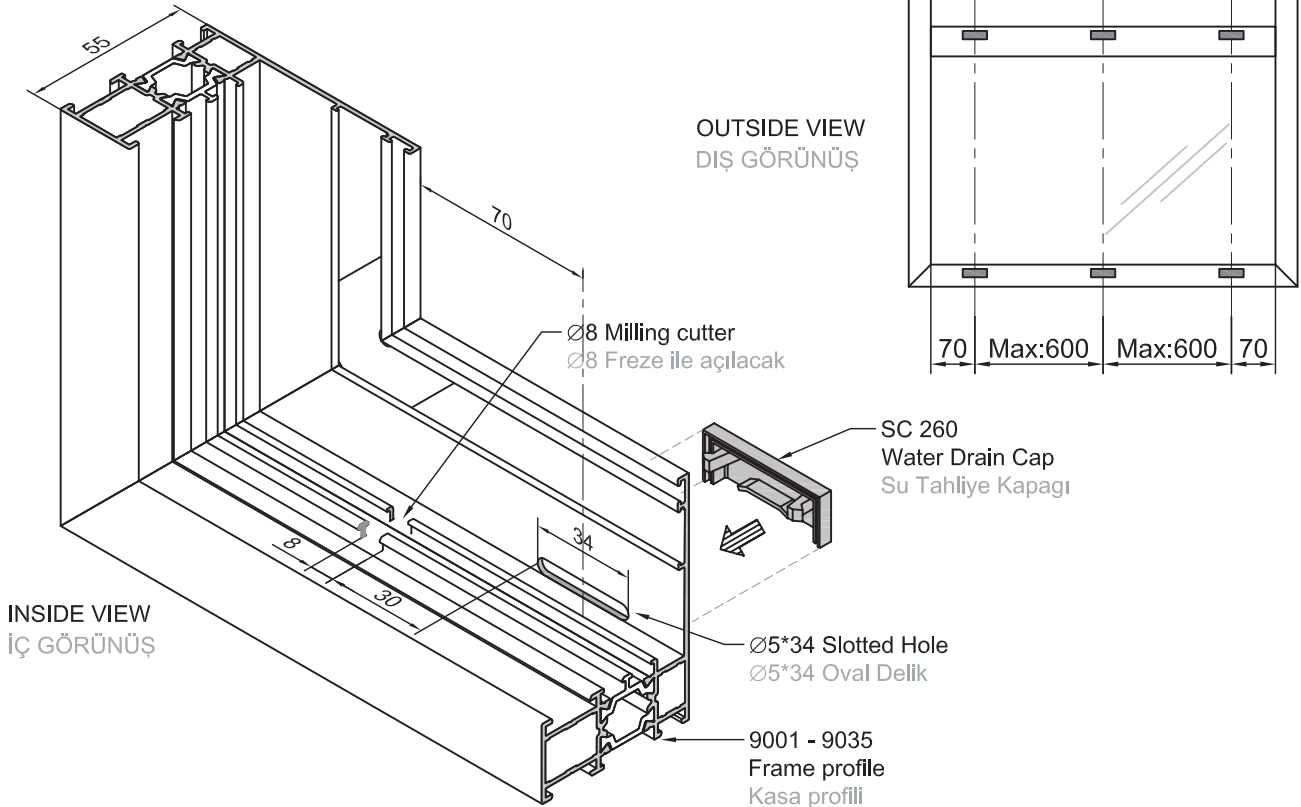

Locking Device Installation
Kilit Karşılığı Montajı

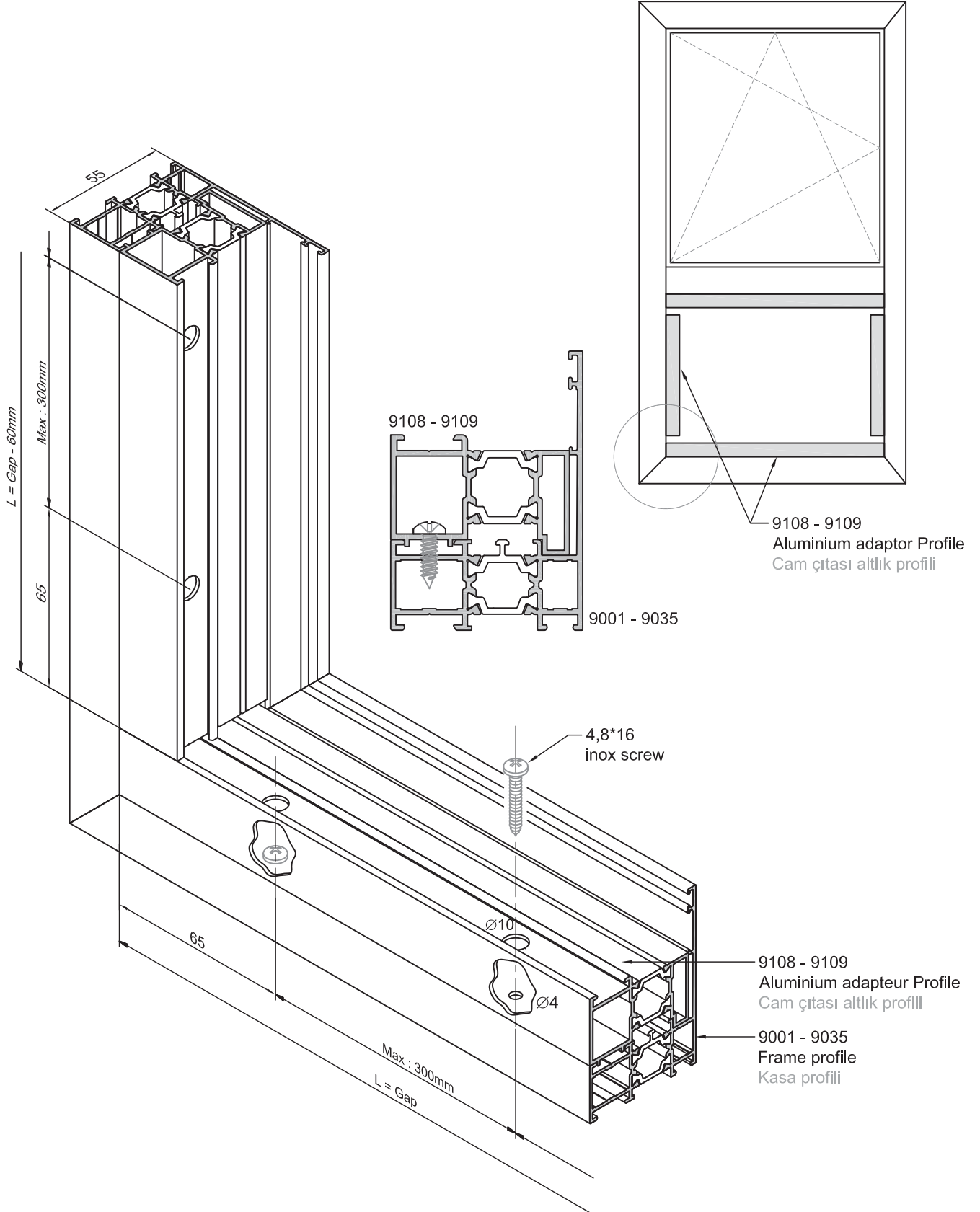

Openable Frames Water Drainage and Ventilation System

Açılır Pencere Su ve Hava Tahliye İşlem Şeması

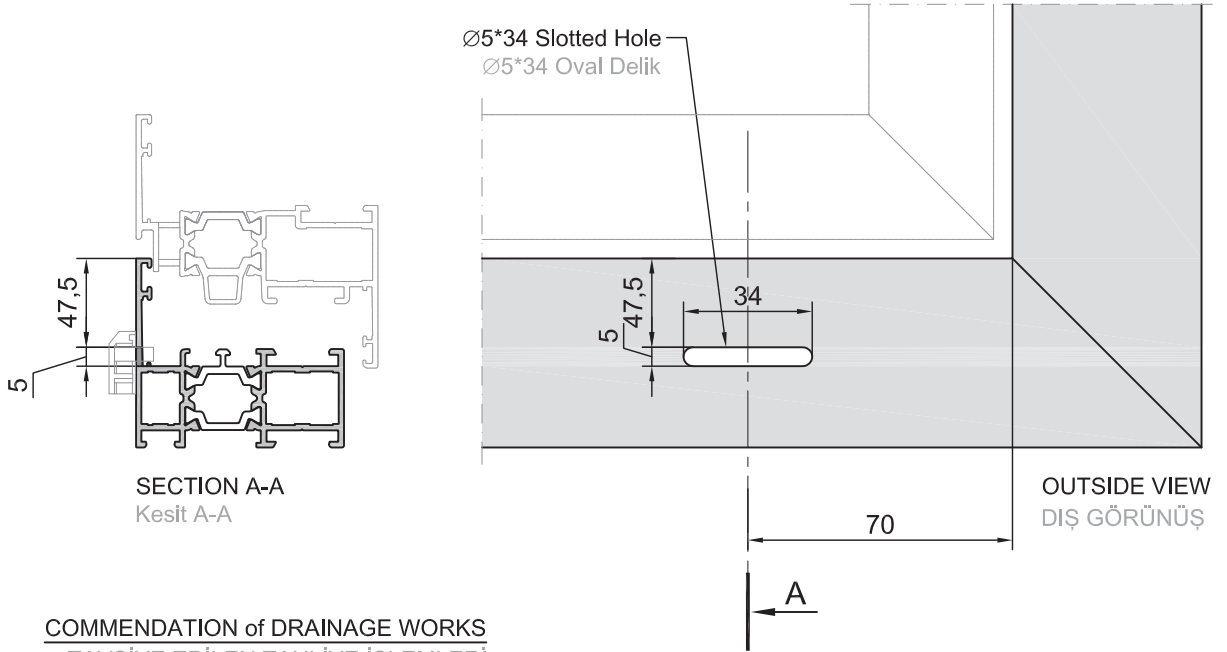

COMMENDATION of DRAINAGE WORKS TAVSİYE EDİLEN TAHLİYE İŞLEMLERİ

- 1 - Correct punching, drilling or milling
Belirtilen delikler için uygun pres freze, kertme yapılmalı.
- 2 - Deburring and Removing dust and saw-dust (if necessary)
Çapaklar ve testere tozları alınmalı (eger gerekli ise)
- 3 - Degreasing with degreaser
Yag artıkları yag çözücü ile temizlenmeli
- 4 - Applying anti-corrosion product
Korozyon önleyici ürün uygulanmalı

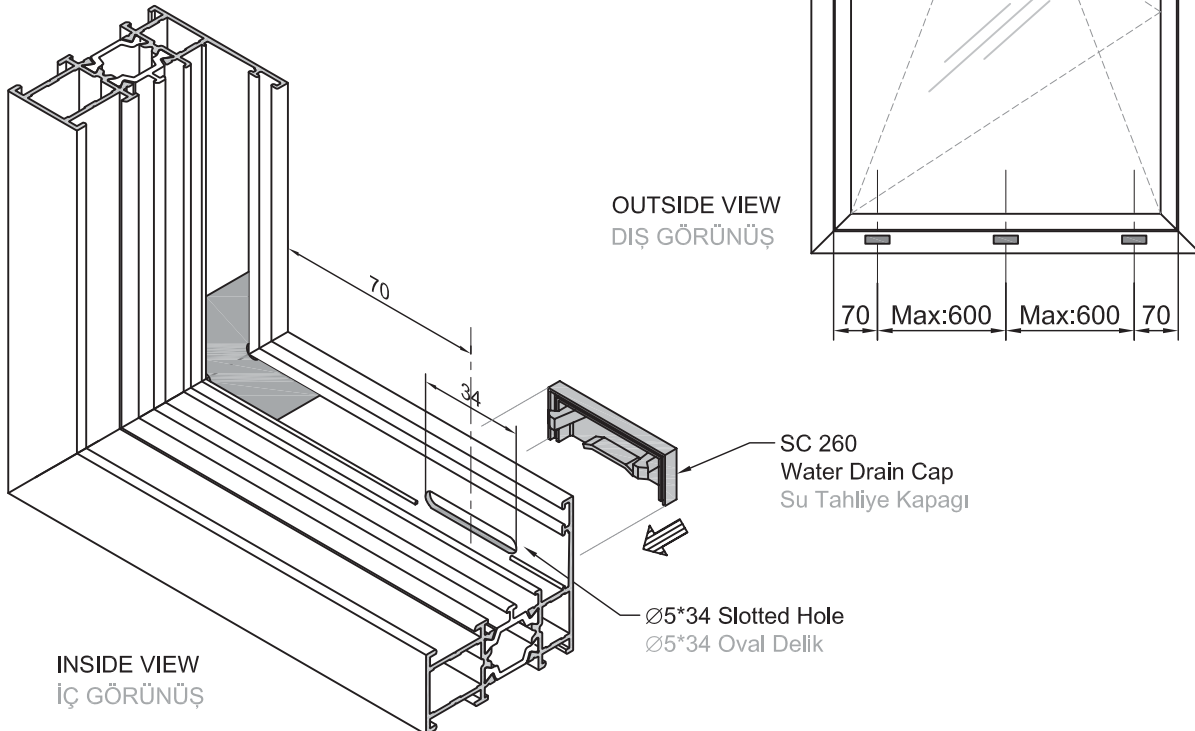

Openable Frames Water Drainage and Ventilation System Açılır Pencere Su ve Hava Tahliye İşlem Şeması

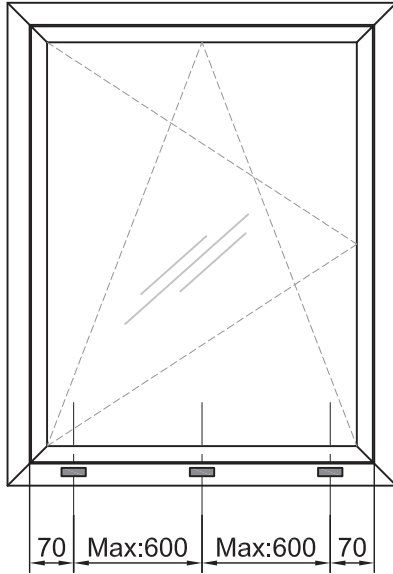

OUTSIDE VIEW
DIŞ GÖRÜNÜŞ

COMMENDATION of DRAINAGE WORKS TAVSİYE EDİLEN TAHLİYE İŞLEMLERİ

- 1 - Correct punching, drilling or milling
Belirtilen delikler için uygun pres freze, kертme yapılmalı.
- 2 - Deburring and Removing dust and saw-dust (if necessary)
Çapaklar ve testere tozları alınmalı (eger gerekli ise)
- 3 - Degreasing with degreaser
Yag artıkları yag çözücü ile temizlenmeli
- 4 - Applying anti-corrosion product
Korozyon önleyici ürün uygulanmalı

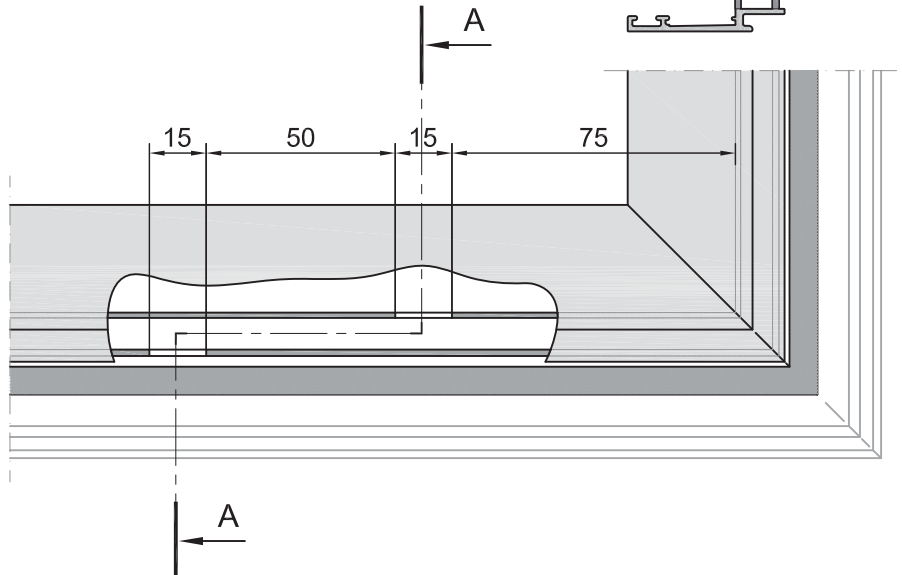
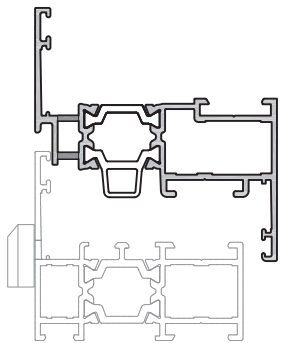
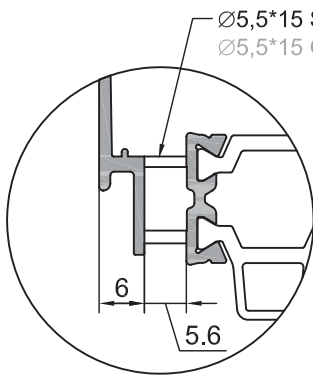
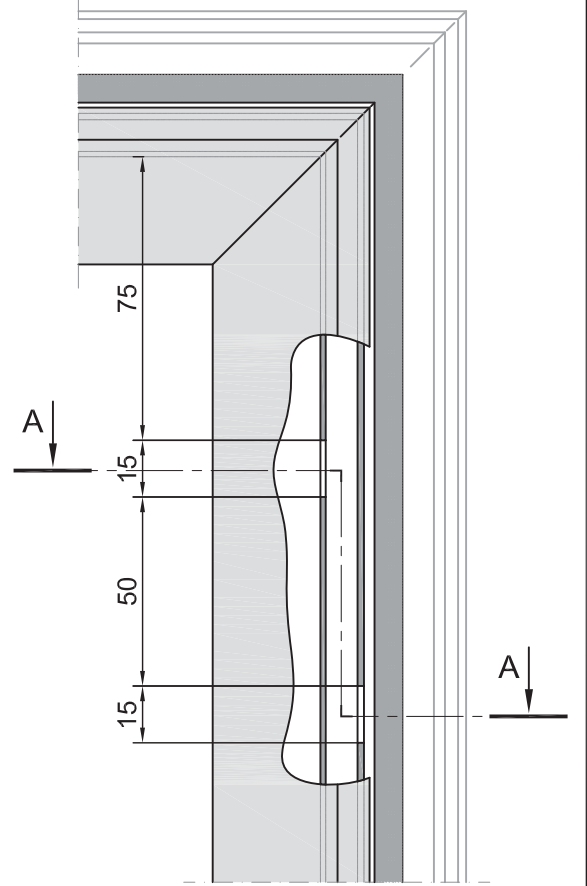

Decompression Drainage for Sash and Frame
Kasa ve Kanat için Basınç Denge Delikleri

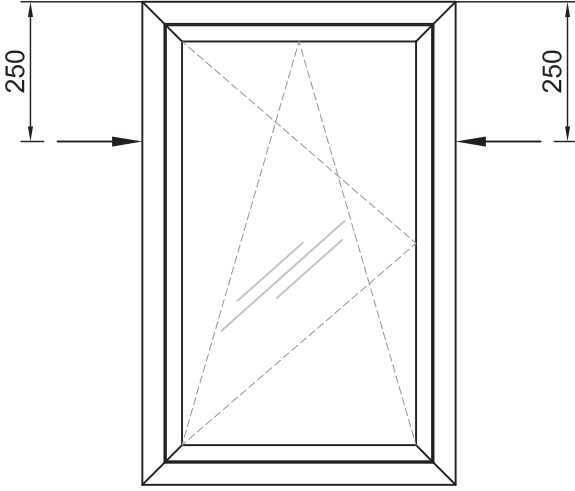

DECOMPRESSION IN SASH
KANAT ÜZERİNDE BASINÇ DENGELEME

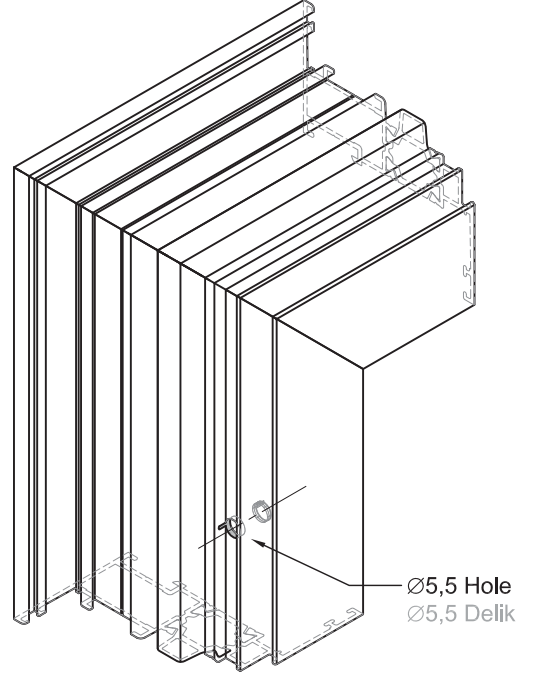

CORNER VIEW
KÖŞE GÖRÜNÜŞÜ

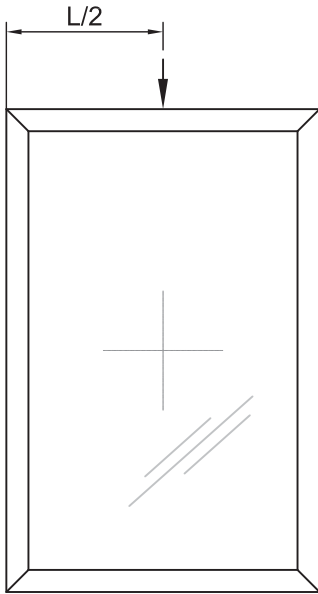

DECOMPRESSION IN FIXED WINDOW
SABİT PENCEREDE BASINÇ DENGELEME

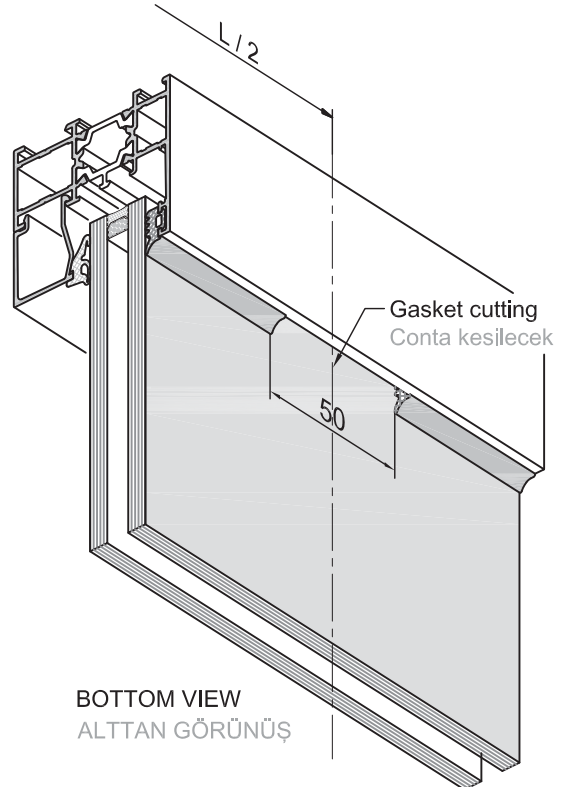

BOTTOM VIEW
ALTTAN GÖRÜNÜŞÜ

Glazing Gasket Assembly
İç Cam Contası Uygulama Şeması

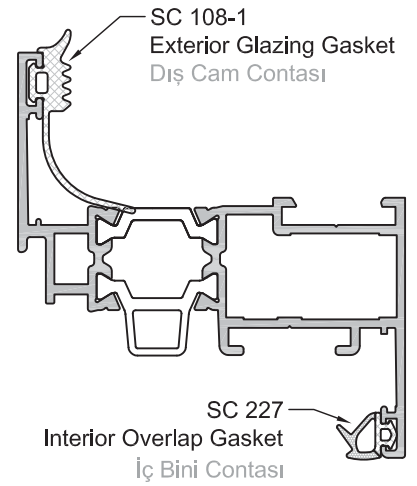
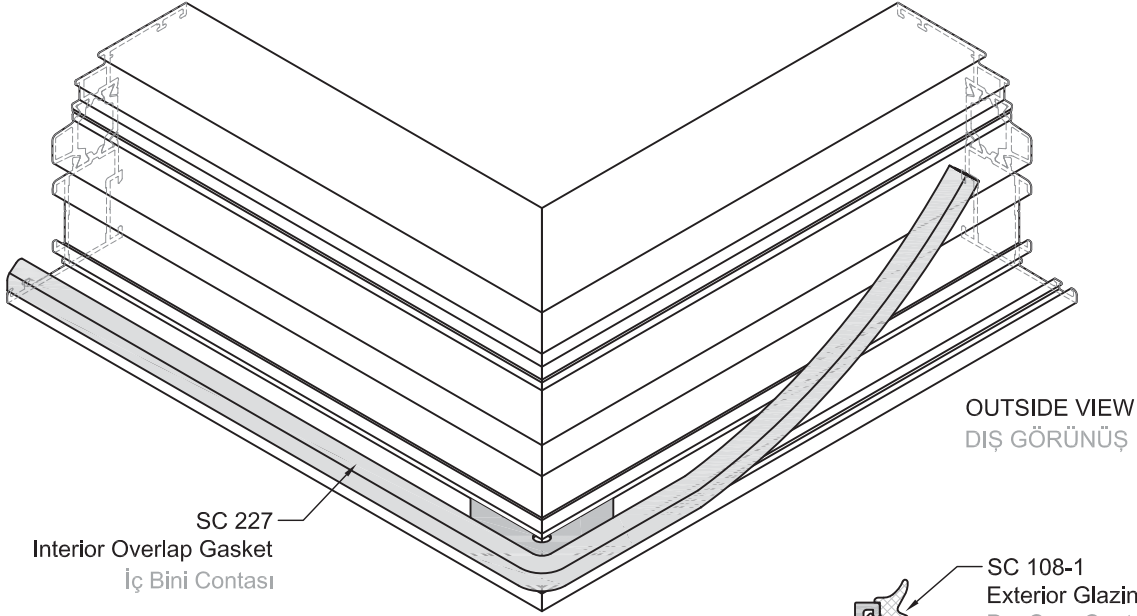

INSIDE VIEW OF 90° FRAME CORNER
90° KASA KÖŞESİ İÇ GÖRÜNÜŞ

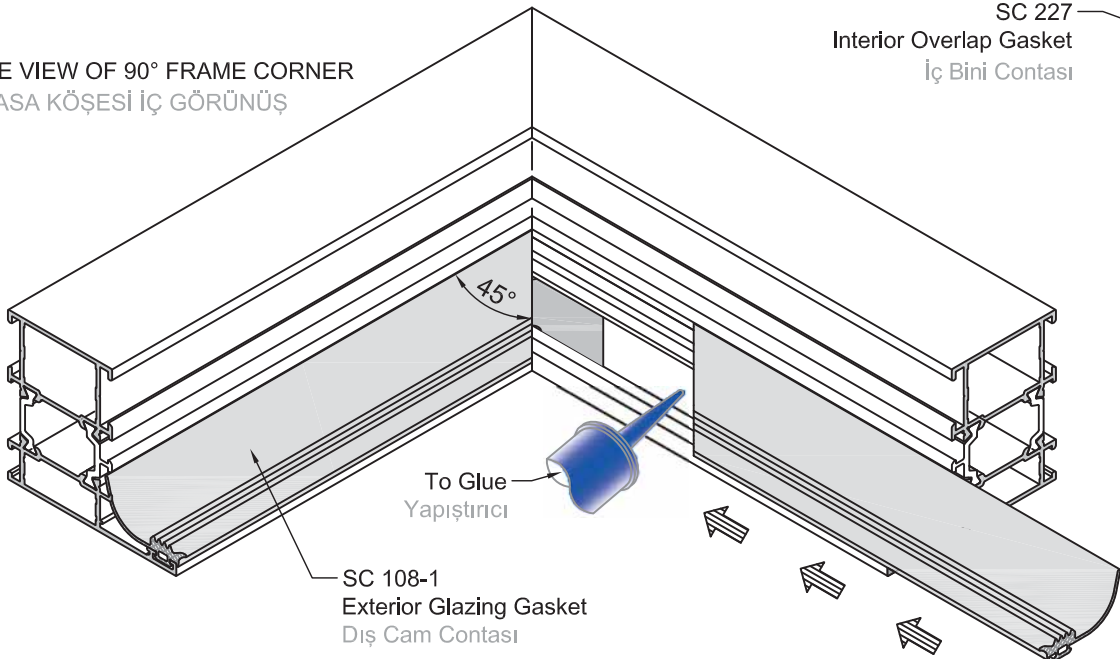

Hinge Installation
Menteşe Montajı

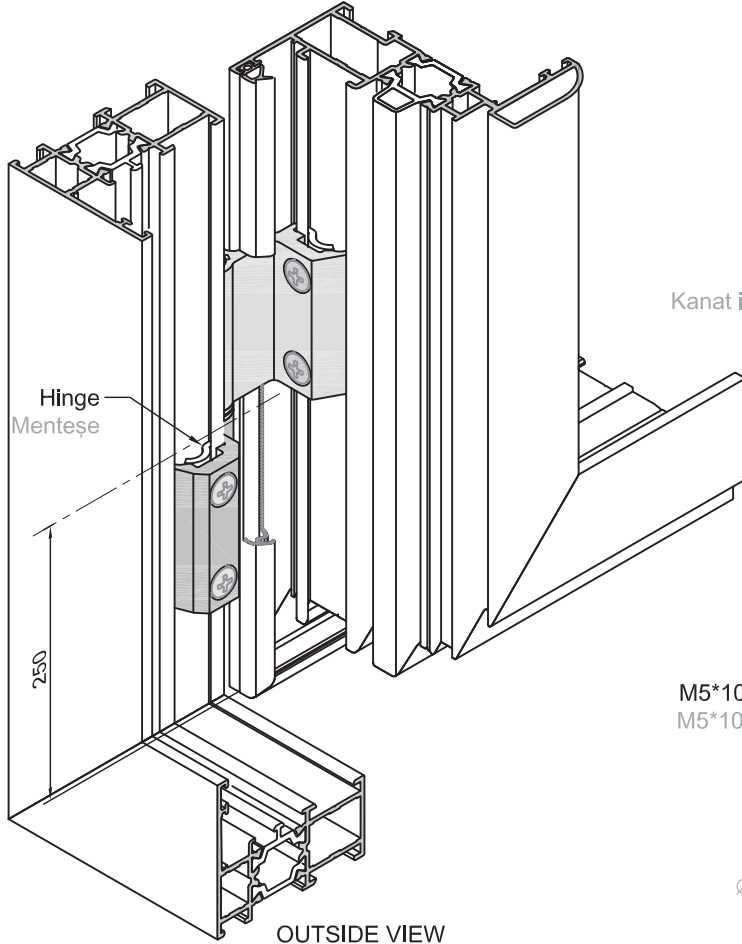

OUTSIDE VIEW
DIŞ GÖRÜNÜŞÜ

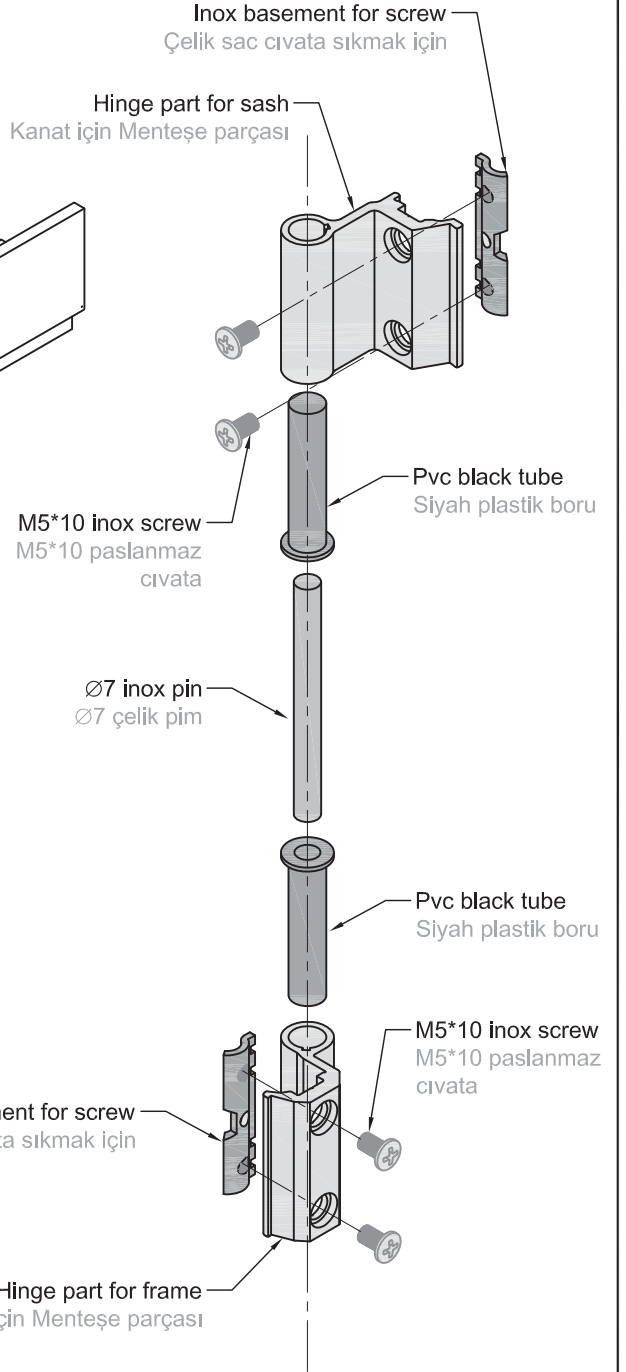
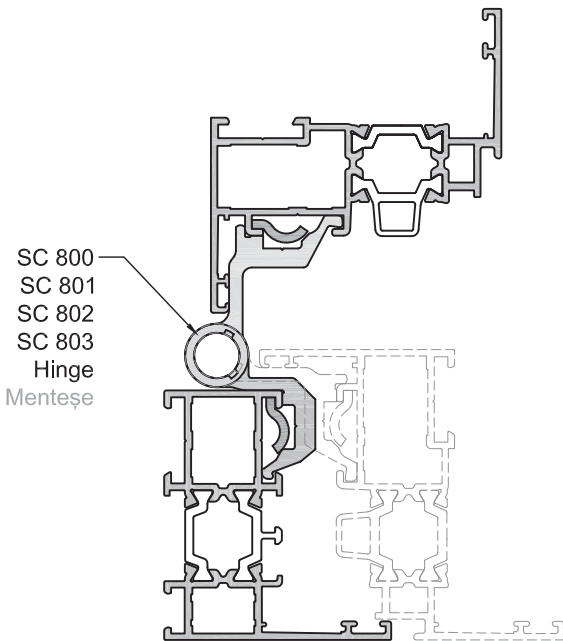

EXPLODED VIEW of HINGE
PARÇA YERLEŞİM GÖRÜNÜŞÜ

Extra Reinforcement Profile Assembly Drawing
İlave Takviye Profil İşlem Şeması

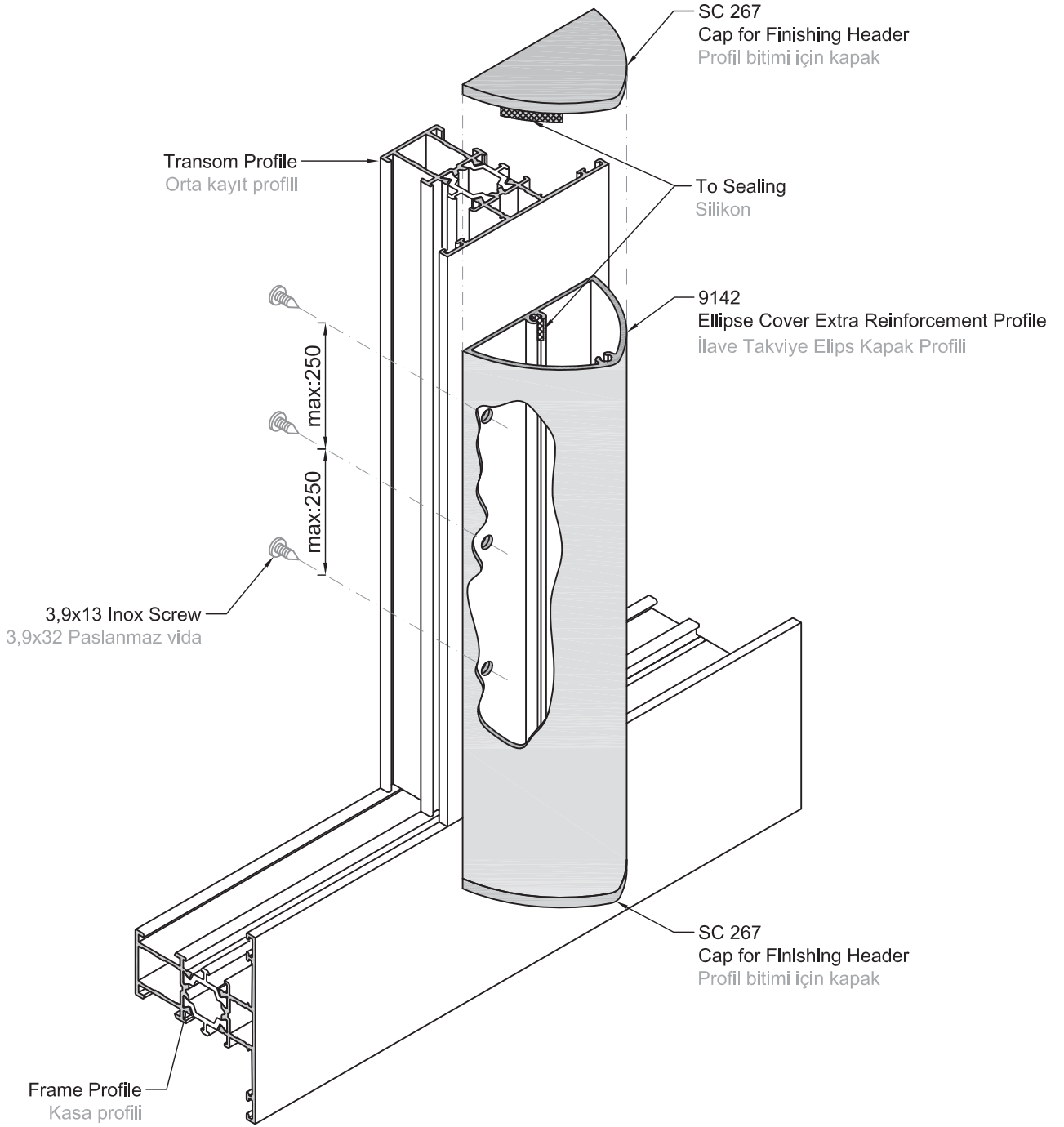

Sloped Synthetic Block Inside Opening Window İçe Açılır Pencere Kaldırma Takozu Montajı

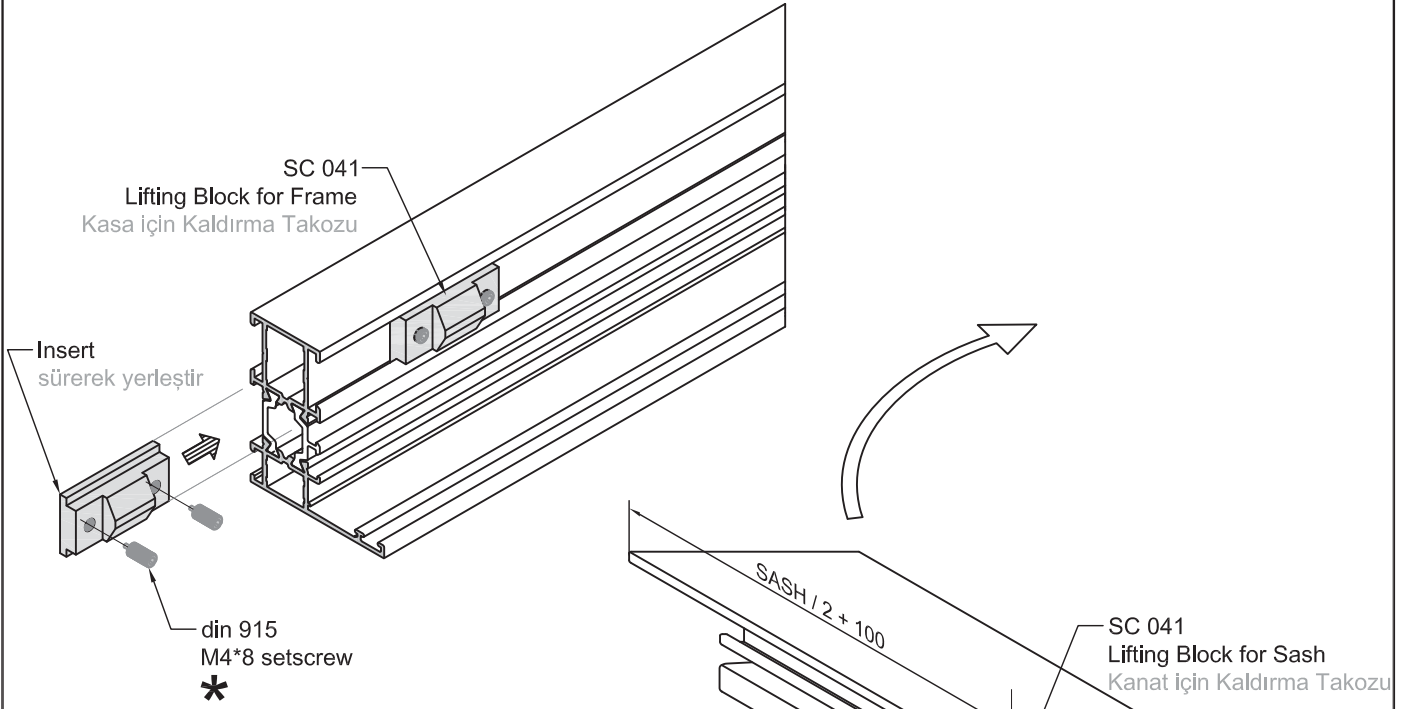

* Tighten screw until it punches through the profile wall
Profil duvarı delinene kadar vida sıkılır

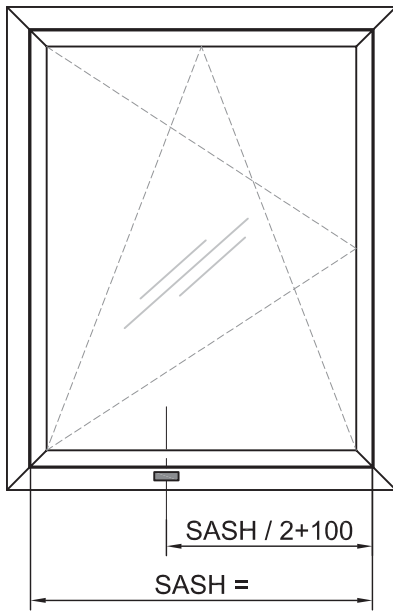

OUTSIDE VIEW
DIŞ GÖRÜNÜŞ

for all accessories: if SASH > 1200 mm

Tüm aksesuarlar için: eğer kanat genişliği 1200mm ve üzeri ise

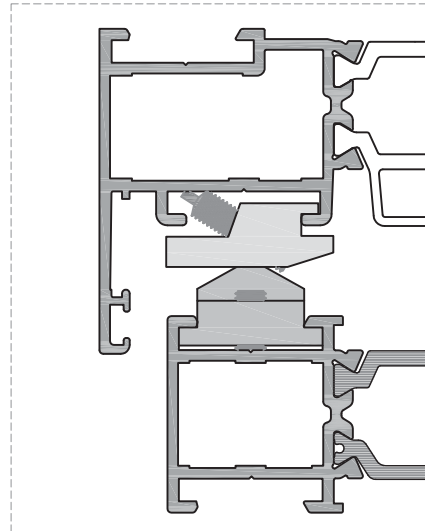

Locking Device Installation
Kilit Karşılığı Montajı

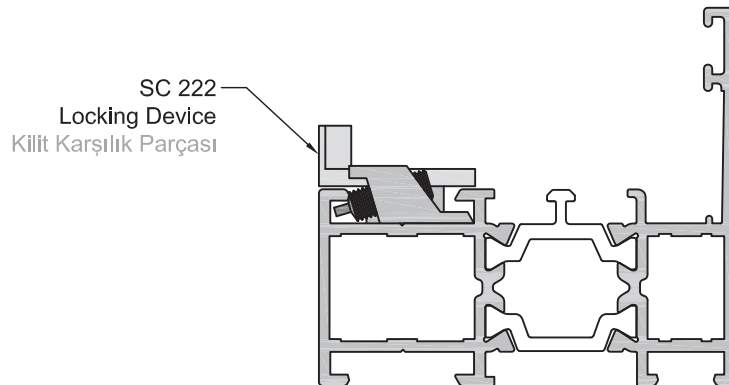
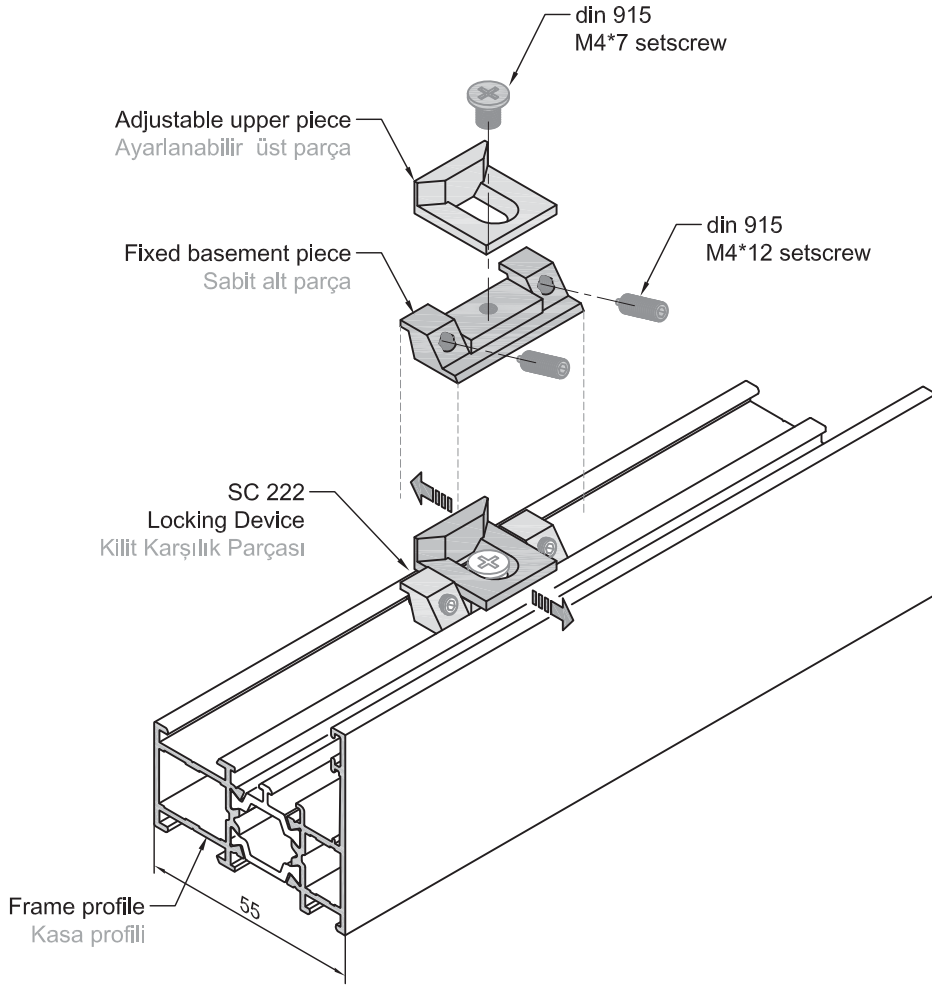

Adapteur profile cutting for pivot window
Pivot pencere için adaptör profil kesimi

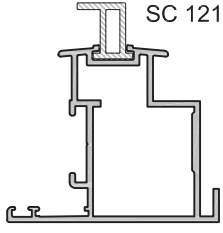

SC 121 PVC PROFİL ÜSTTEKİ GİBİ ADAPTÖR PROFİLE
TAKILMALIDIR.
SC 121 Pvc profiles must be install into the adapteur
profile as like above

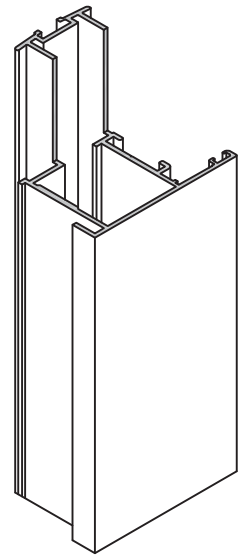
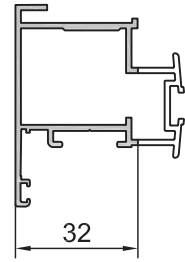
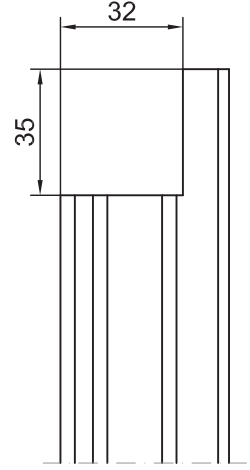
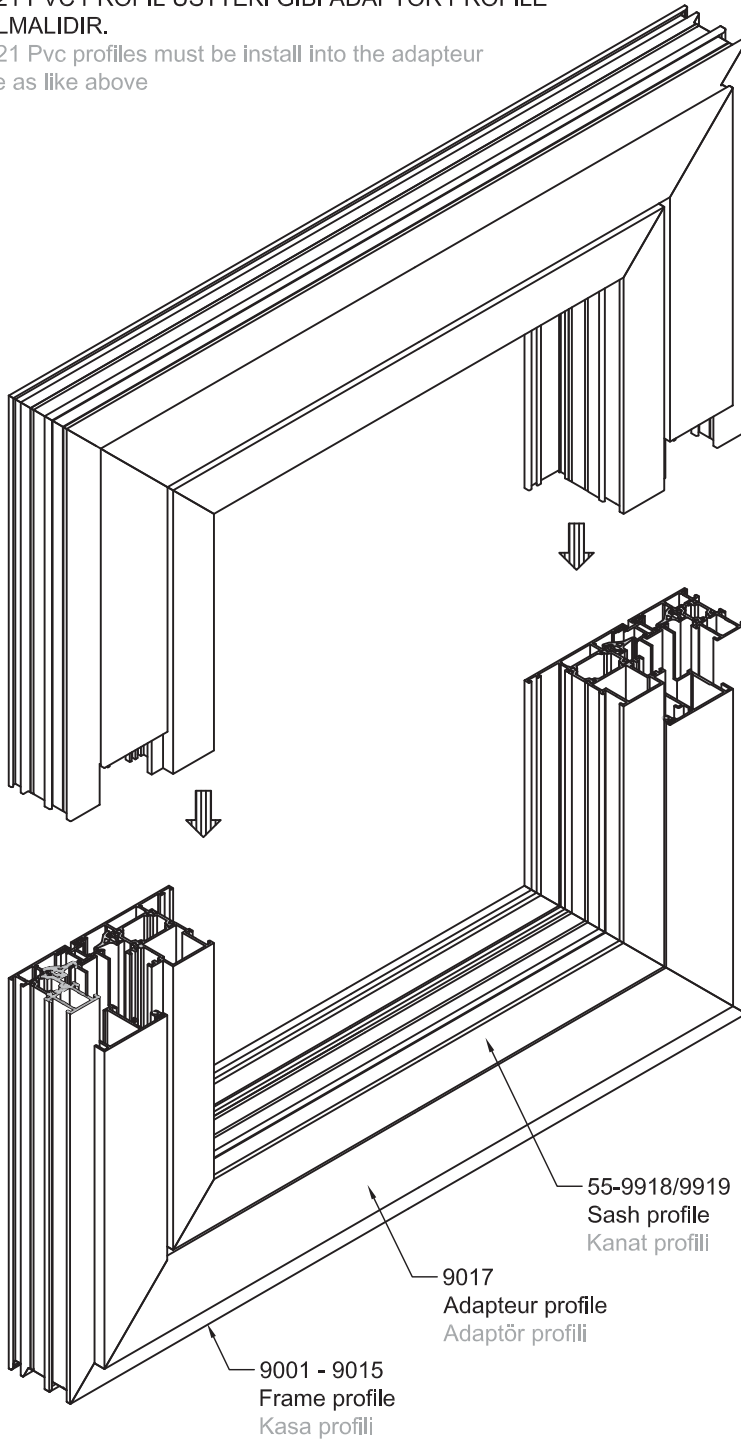

Adapteur Profile Routing
Adaptör profili kertmesi

Rod profile cutting for horizontal pivot window
Yatay Pivot pencere için tij profil kesimi

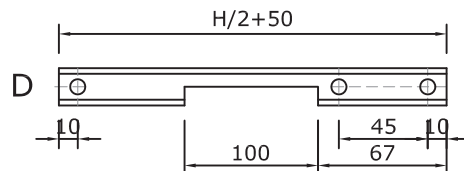
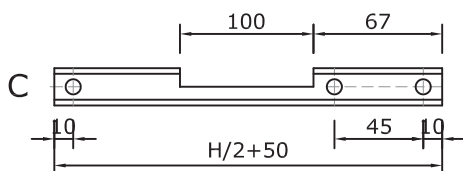
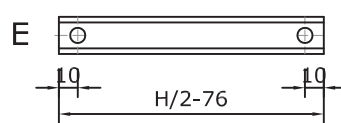
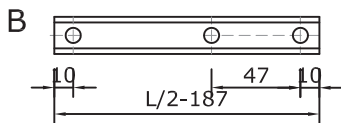
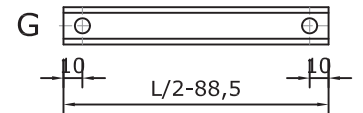
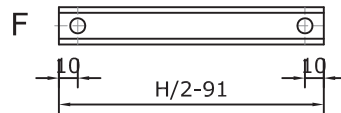
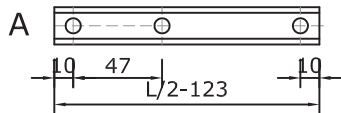
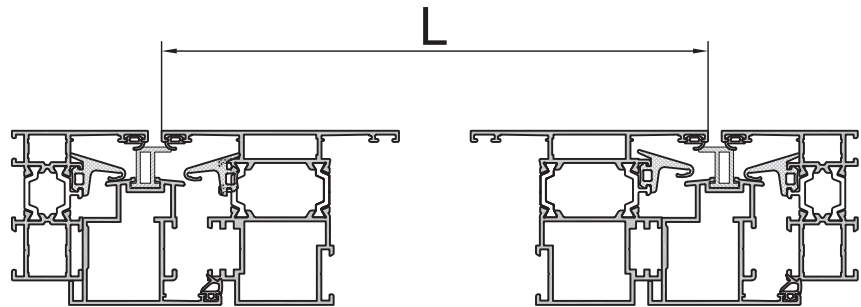
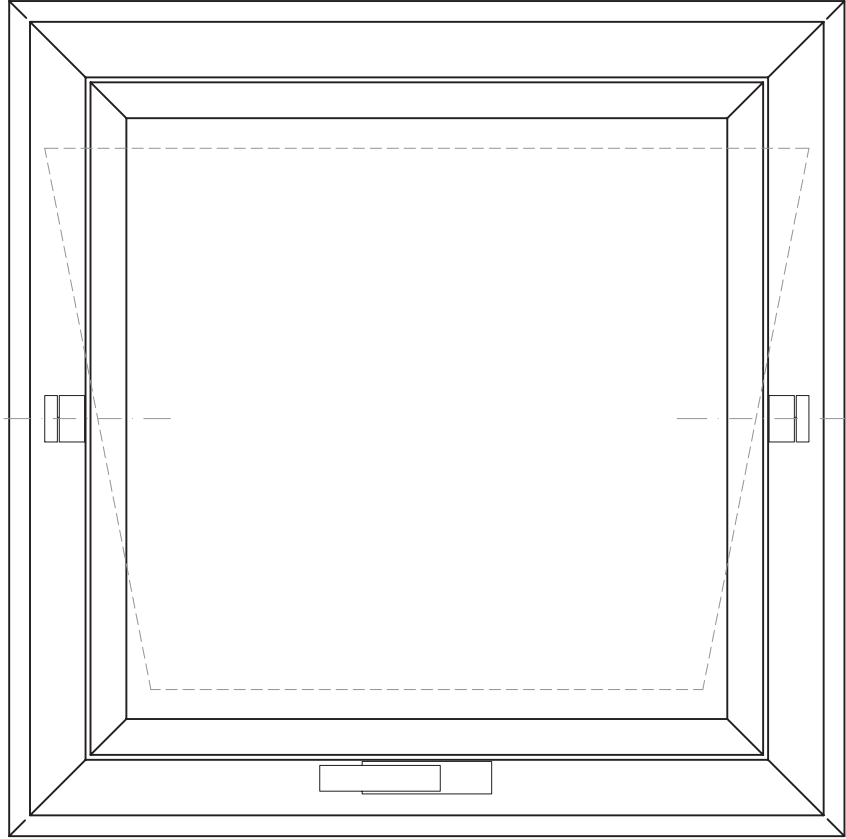
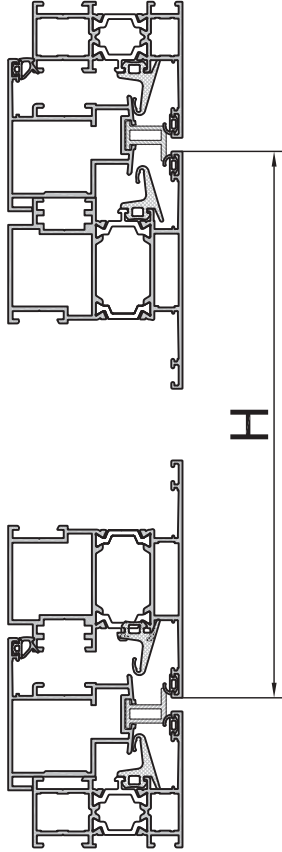

Rod profile cutting for Vertical pivot window
 Düşey Pivot pencere için tij profil kesimi

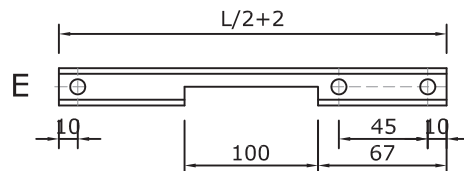
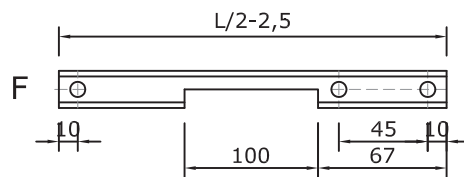
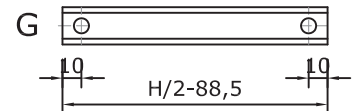
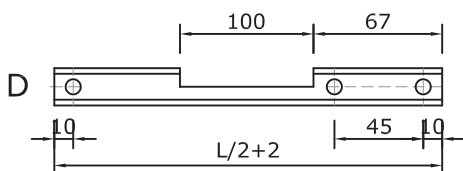
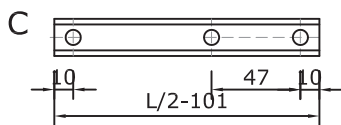
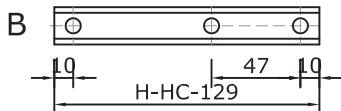
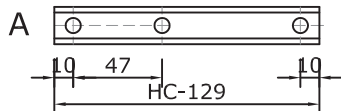
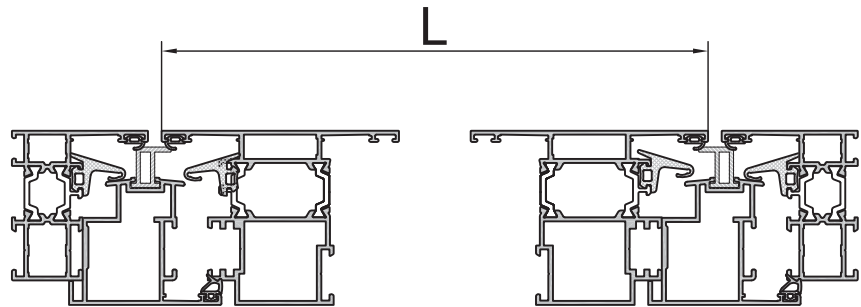
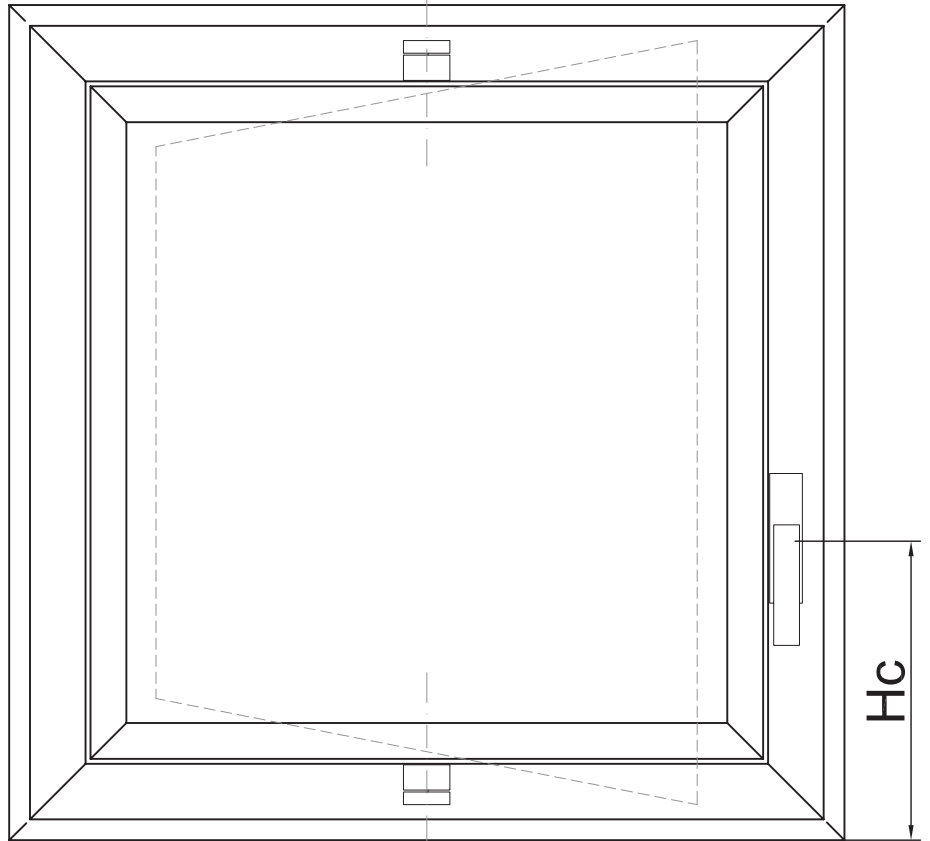
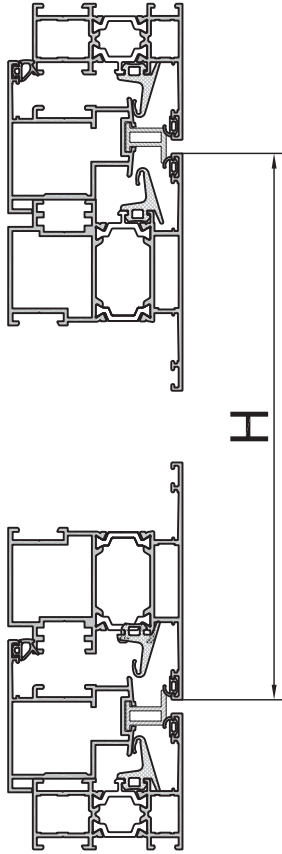

Folding Doors Application Types

Katlanır Kapı Uygulama Tipleri

TİP 321

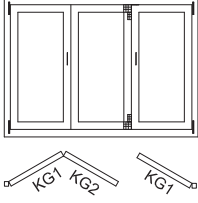

TİP 330

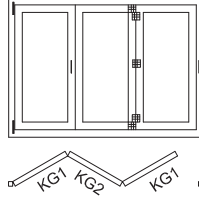

TİP 431

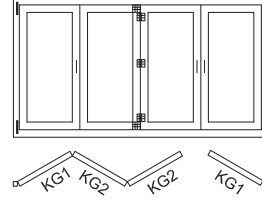

TİP 541

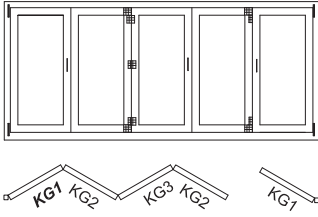

TİP 550

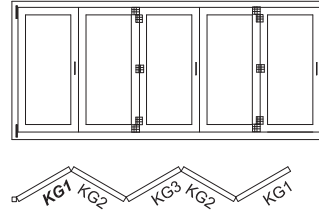

TİP 532

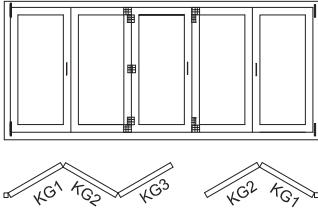

TİP 651

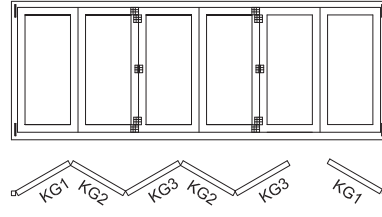

TİP 633

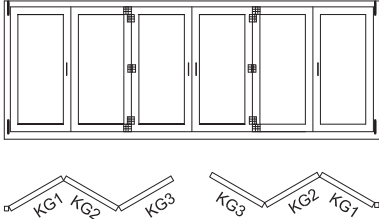

TİP 761

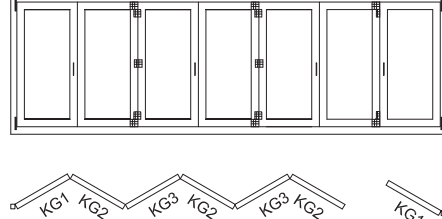

TİP 770

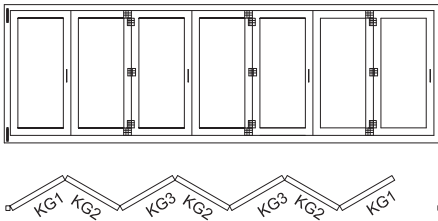

TİP 743

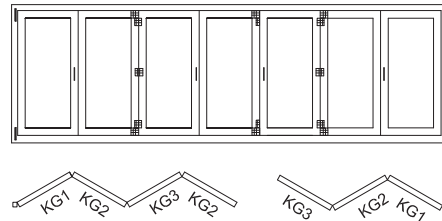

KATLANIR KAPI MEKANİZMASINA AİT GENEL BİLGİLER

Kanat Geniřliđi (KG): Min 600 mm-Maks 900 mm

Kanat Yüksekliđi (KY):Min 850 mm-Maks 2400 mm

Kanat Ađırlıđı: Maks 80 kg

MEKANİZMA DAR KASA VE DAR KANAT İLE UYGULANMAZ !